



BEAUTIFUL EXPERIENCES
ARE MADE OF BEAUTIFUL
CONTRADICTIONS.



Our years and days all have something in common. They're not quite what they seem. Never just beginnings, middles and ends but interesting series of surprises, shocks, delights and u-turns. Yet they always reward. With interest. Enrichment. Confidence. Fulfilment and joy.

IN SHORT, THEY'RE CONTRADICTIONS.

Many designers assume that lives fit categories. Regular. Happy. Every-day. And that places and things should do the same. Functional. Square. Bright. Inspirational.

Experience tells us that lives, no matter how they seem, just aren't so. So indeed, nor should be their environments or possessions. Or their furniture. After all, it's a part of life, like air, love or breakfast. To us, design should fit its users' daily contradictions. By being contradictions in themselves.

THE PIRA SHELF.

A CONTRADICTION BORN FROM ANOTHER.

The Pira shelf is as contradictory as the man who conceived it. And the people it coexists with.

Olle Pira was a traditional master cabinet-maker. He crafted cherry, maple and matured oak with age-old skills. Yet he still won a place at the renowned Konstfack school of art, craft and design. The birthplace of concepts ahead of their times.

Hence, in 1954 he designed a mechanical miracle that adapted to various heights, yet bore eye-stretching loads. And simultaneously, exuded a confident calm. A sensation that all was well and cared for. Even if its owners didn't know where the world was going tomorrow.

The Pira shelf. As contradictory as the lives it's enhanced. From German librarians to office managers to contradictory global characters from TV, stage and screen.

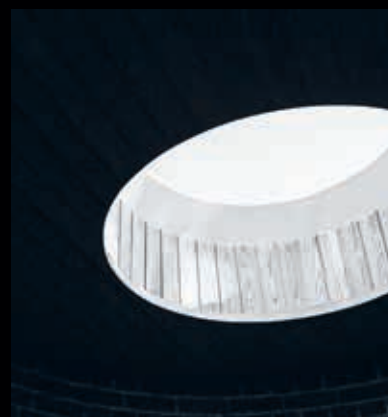

Villa Bäckström, a house in brick, wood and glass.

The staircase in Villa Bäckström. A spiral, yet adorned with an upright tower: a Pira G2 in black grey laquered metal, with a walnut cabinet. 700mm wide, 2000mm high.

"A SHELF SHOULD ENHANCE SPACES AND ABOVE ALL IT SHOULD STORE POSSESSIONS. A PERSONAL COMPANION TO HUMAN NATURE."

Anna von Schewen

"WE SEE THE SHELF AS A PLATFORM TO ACCOMODATE DIFFERENT ASPECTS OF LIFE".

Anna von Schewen



Rustic, yet urban. Wood next to metal.



8 ELEGANTLY DELICATE, YET FRANKLY ROBUST. LIKE LIFE.

9 PIRA G2 IS A SPUN, METALLIC WORK OF ART THAT CREATES A CENTRE-PIECE WHEREVER IT STANDS. EVEN FAR FROM THE CENTRE OF A SPACE. YET EACH SHELF CARRIES UP TO 50 KG, THANKS TO ITS SHEET-STEEL CONSTRUCTION WITH AN INTEGRAL RIDGE. OR INDEED, 350 KG IN EACH SECTION. ENOUGH FOR LIFE'S TREASURES. OR NECESSITIES. OR BOTH.



Wall mounted white, 2000mm high. Cabinets in oak, 900mm and 700mm, on a 900mm shelf. Solid white oak bookends. Striking, yet soothing.

PIRA G2.
VINTAGE GENIUS, YET IN A NEW MINDSET.

And now here are the 2020's. Technology, materials and workspaces have evolved. So have humanity's habits and needs. People remain as beautifully unfathomable as ever, yet 21st Century living has evolved faster. So the Pira shelf has responded. Designers Anna von Schewen and Björn Dahlström have taken the classic on. In all senses.



ELEGANTLY DELICATE, YET FRANKLY ROBUST. LIKE LIFE.

Pira G2 is a spun, metallic work of art that creates a centre-piece wherever it stands. Even far from the centre of a space. Yet each shelf carries up to 50 kg, thanks to its sheet-steel construction with an integral ridge. Or indeed, 350 kg in each section. Enough for life's treasures. Or necessities. Or both.



Anna von Schewen, architect.
Björn Dahlström, industrial designer.

A UTILITY, YET A CENTREPIECE.

Belongings have evolved. So a shelf has to bear them. IT hardware that ages faster than bread. Home cinemas, gyms, pasta-factories and libraries. First editions. First growths. One-offs.

Simultaneously, ceilings have risen and spaces have opened up. Pira G2 remains a centerpiece, whether bridging a room's height, or gracing a wall. No matter what's on it.



Olle Pira in his studio in the 1960's.

CONTRADICTION, YET CONSUMMATE.

When all is said and done, Pira G2 is a shelf. Not a rocket to Saturn. But thanks to the efforts of some of Sweden's most bright and wayward minds, it's an engineered masterpiece.

A complex and sophisticated one indeed. But capable of creating calm and wellbeing wherever it lives. And whatever lives on it.

Opposite: His original 1954 blueprint, an integrated mix of triangles and materials.

Next page: See how Pira G2 boils them down to one.

"DISTINCT, YET INVITING. TWO SYNERGETIC ATTITUDES.
DERIVING FROM THE AMBITION TO ORGANISE."

Björn Dahlström

"PIRA G2 MEETS THE NEEDS OF TODAY. YET STRIVES TO RETAIN
THE BRILLIANCE OF THE 50'S CLASSIC. ITS RELEVANCE SALUTES
THE PAST."

Björn Dahlström

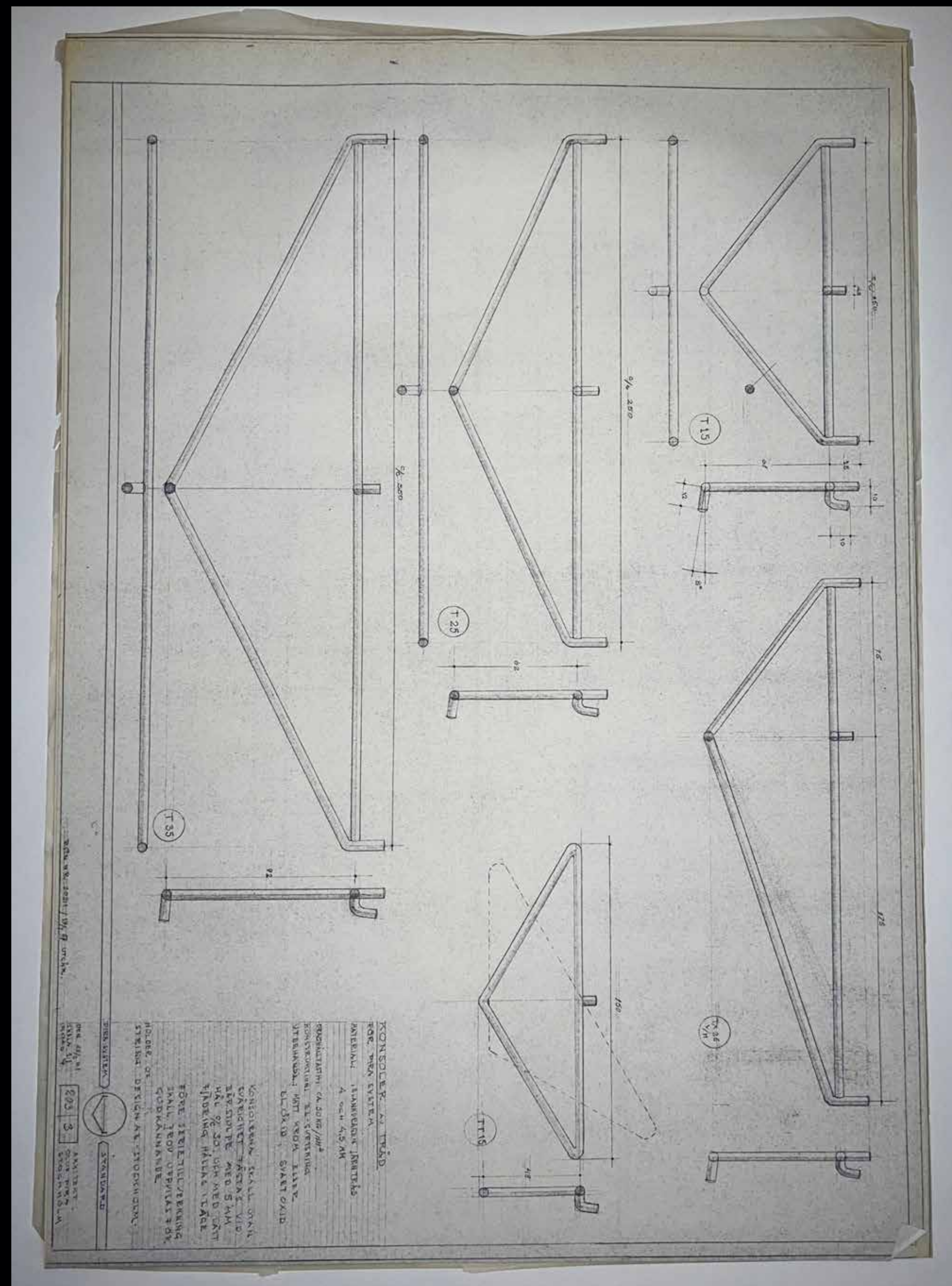



Poles in extruded aluminium and wings in steel, pressed to precisely fit the pole's opening. That way, uprights and wings become a seamless entity. And every shelf, rock steady.

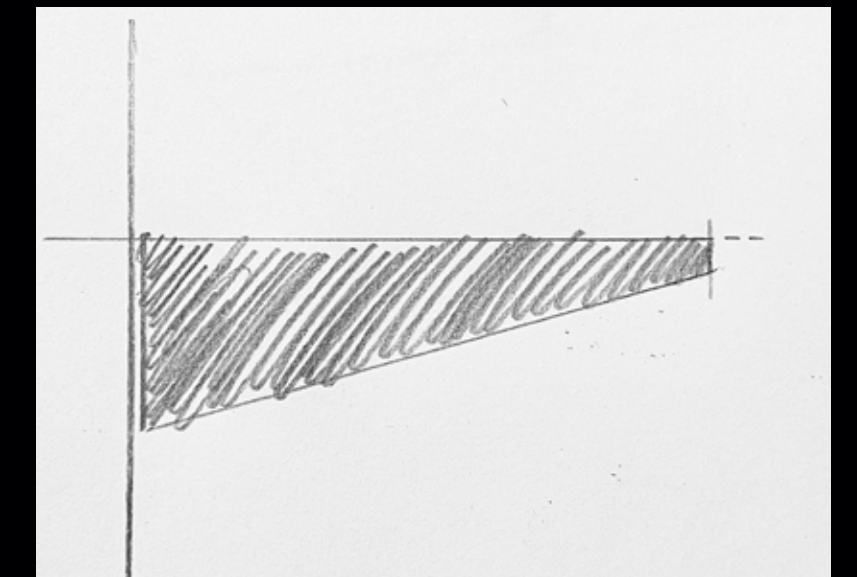
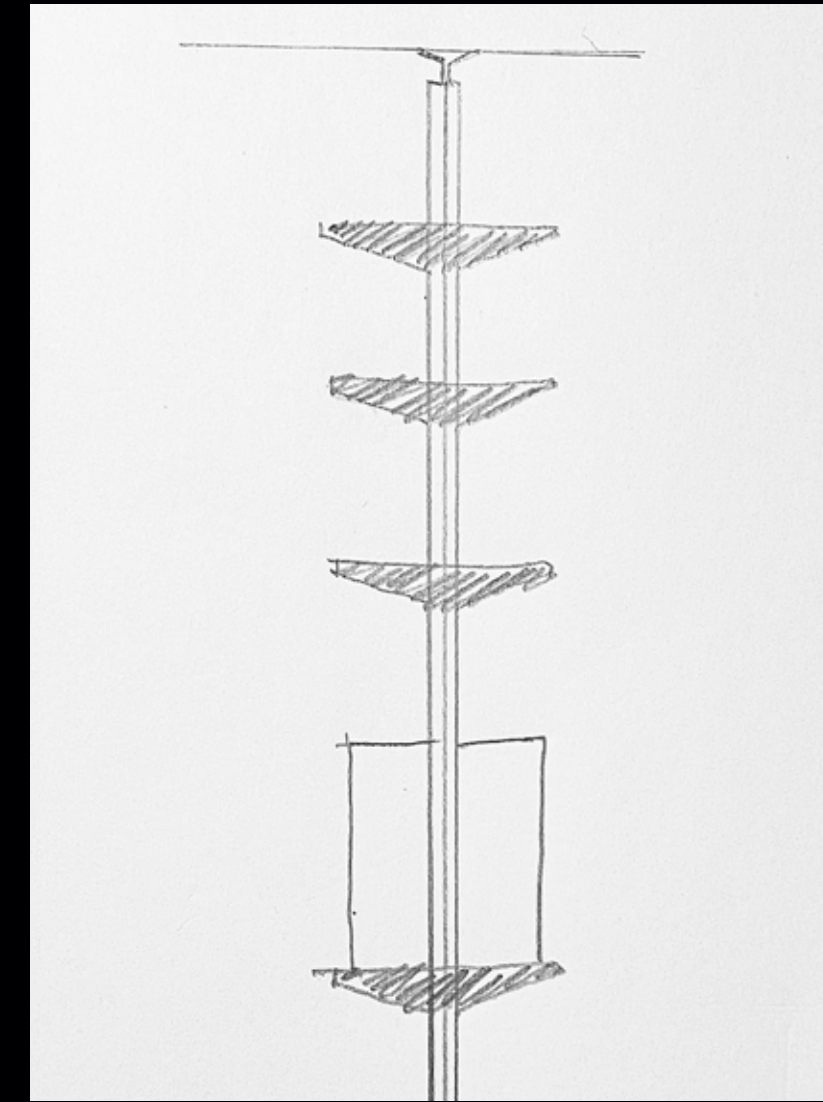

Anna von Schewen's and Björn Dahlström's original 2019 sketches. Simpler, yet equally rich.

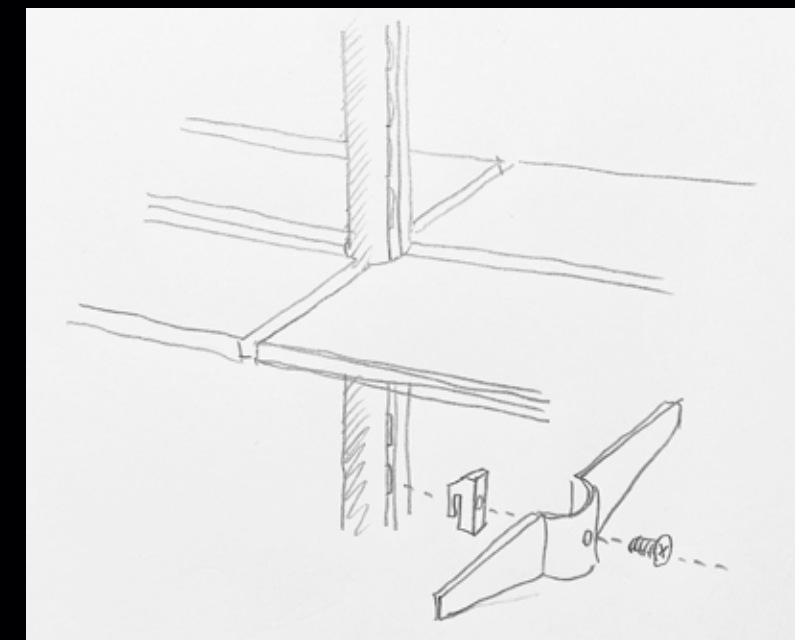

UPHOLDING, YET MELLOWING.

PIRA G2'S METALWORK REASSURES. YET ITS WALNUT AND WHITE OAK BOOKENDS AND CABINETS PACIFY. A TECHNICAL FEAT, YET A BEAUTIFUL ONE. TWO SCHOOLS IN ONE SPACE. THE WELCOMING, AND THE WORKING.

MODULAR, YET SEEMINGLY JOINTLESS.

MODULAR ENOUGH TO FIT ON A SINGLE PALLET FOR A ONE-SHOT DELIVERY. YET ASSEMBLED, GIVING THE PERCEPTION TO HAVE BEEN BUILT AS ONE. A SEEMINGLY JOINTLESS APPEARANCE WITH NO BEGINNINGS AND ENDS. A REASSURANCE FOR THOSE OF US WHOSE LIFE IS TO THE CONTRARY.

LIKE A SWISS WATCH, AND A TOWER CRANE.

PIRA G2 IS THE SUM OF MANY PARTS. AN INTERLOCKED SERIES OF JOINTS, POLES, FLATS AND TRIANGLES, EACH NO LONGER THAN A METRE YET EXTENDABLE TO MORE THAN THREE, REACHING MOST CEILINGS FROM ALL FLOORS. WITH MACHINED TOLERANCES DOWN TO 0.02 MM, YET ALL AS RUGGED AS THE MACHINES THAT CUT THEM.



Bookends in solid walnut.
Stout enough to hold many first editions,
yet not enough to hide them.
See how the aluminium bar elegantly
slides within the fold of the shelf.

A suspended 2x900mm black grey metal and walnut unit,
holding a 900mm and a 700mm wide cabinet. Room for air
as well as life's essentials. Practicality and beauty in a frame.



PIRA G2. A MOST BEAUTIFUL CONTRADICTION.



5.

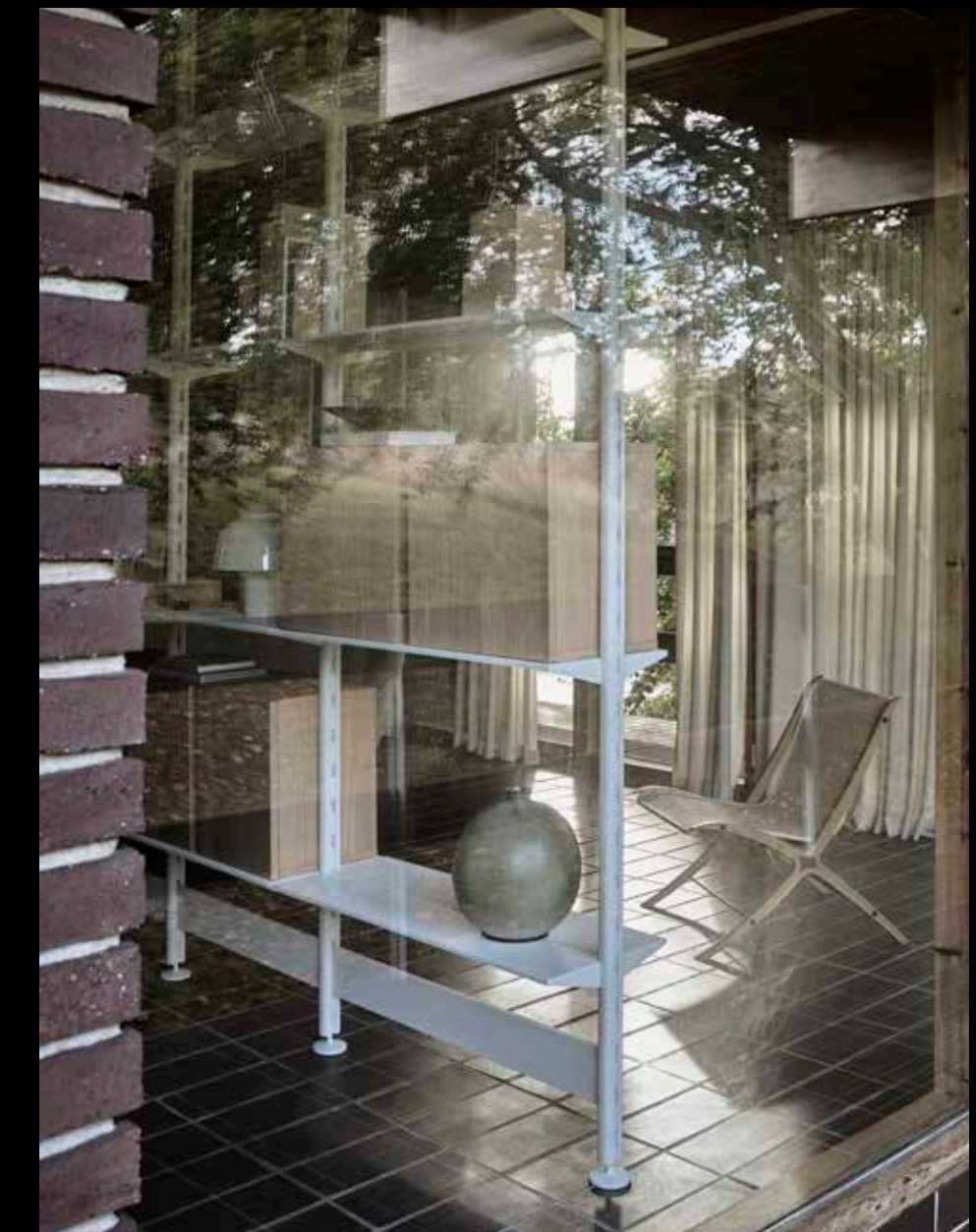

Pira G2 is the sum of many parts.

1. A stout organiser with three compartments, in white oak.
2. A foot firmly placed in the ceiling. Adjustable distance 30–80mm.
3. Large cabinets in white oak. Two widths, 700mm and 900mm.
4. A solid bookend in white oak.
5. A floor-to-ceiling Pira G2 with cabinets in white oak and choice belongings.



A house, yet a castle. Villa Bäckström in Hässleholm, Sweden. Designed by architects Fritz Jaeneke and Sten Samuelsson in 1971 for the Bäckström family. The spiral staircase in the centre ties the two floors together. The upper level, an ocean of translucent light with floor to ceiling windows. The lower, a practical space with offices, storage and garage. As contradictory as Pira G2.

