

# Product information

ENGLISH

LAST UPDATED FEBRUARY 2026

**Montana**

# INDEX

---

<b>MODULAR STORAGE SYSTEMS</b>	<b>5</b>	HiLow Table	266
Montana System	8	HiLow 2	268
Special Modules:		HiLow Double	272
Bar Module and Desk Module	29	HiLow 3	274
Living Things	30	HiLow Conference	276
Modules with Sliding Doors	32	HiLow Speaker	286
Load Capacity	34	SHL Table	291
TV & Sound	36	Load Capacity Overview for Tables	294
System Seating	46		
Hall	54	<b>PANTON</b>	<b>297</b>
Mega	58	Panton Wire (Modular storage systems)	102
Mini	62	Panton One (Seating and Chairs)	194
Wardrobe	68	Pantonova (Seating and Chairs)	212
Montana Selection	80	Panton Table (Tables)	242
Montana Free System	88		
Skyline	98	<b>ACCESSORIES</b>	<b>301</b>
Panton Wire	102	Mirrors	304
Montana Office System CO16	106	Storage Boxes	306
Office Units	124	Magnetic Noticeboard	308
Cargo	132	Coat Racks	309
Lockers	140	Trays and Small Storage	310
Montana Office Selections	146	Cushions (System Seating)	50
<b>SEATING AND CHAIRS</b>	<b>153</b>	<b>BATHROOM</b>	<b>315</b>
Kevi	156	Basin Modules	318
Chairik	172	Storage Modules	320
Marée	188	Mirrors (Accessories)	304
Panton One	194	Bathroom - Technical Information	324
Joint	200		
Paradigm	204	<b>MONTANA COLOUR</b>	<b>327</b>
Pantonova	212	Technical information	328
Outdoor seating	221		
Load Capacity Overview for Chairs	218	<b>TECHNICAL DESCRIPTION</b>	<b>333</b>
<b>OUTDOOR</b>	<b>221</b>		
<b>TABLES</b>	<b>225</b>		
Monterey	228		
JW Table	232		
Multi Table	236		
Panton Table	242		
Kevi Table	246		
Moser Table	250		
Foldit Table	258		
Djob Table	263		

# VISUAL INDEX

---

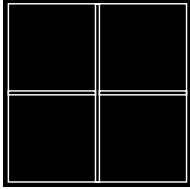

**Modular Storage Systems** 5

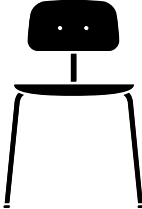

**Seating and Chairs** 153

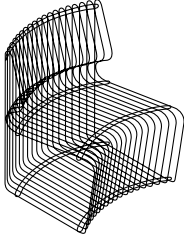

**Outdoor** 221



**Tables** 225

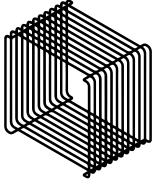

**Panton** 297



**Accessories** 301

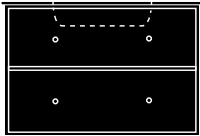

**Bathroom** 315



**Montana Colour  
Technical information** 327



**Technical description** 333



# MODULAR STORAGE SYSTEMS





# INDEX — Modular Storage Systems

---

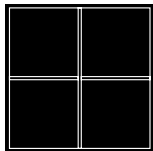

Montana Systems

8



TV & Sound

36

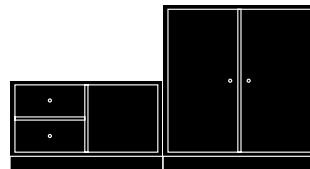

System Seating

46



Hall

54

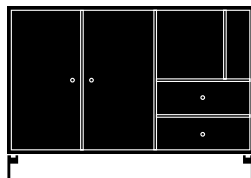

Mega

58

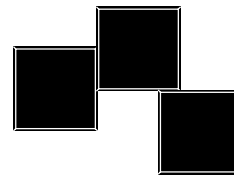

Mini

62

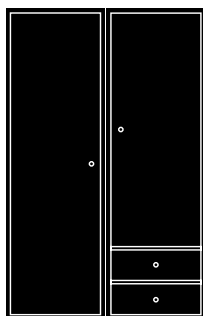

Wardrobe

68

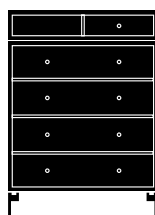

Montana Selection

80

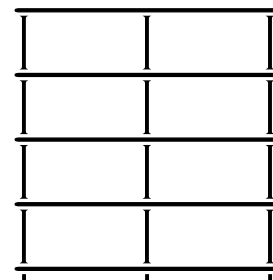

Montana Free System

88



Skyline

98

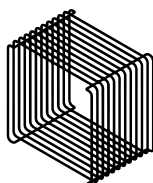

Panton Wire

102

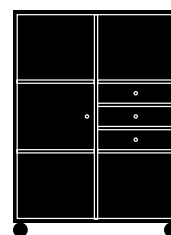

Montana Office System CO16

106



# INDEX — Modular Storage Systems

---

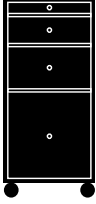

---

Office Units

124

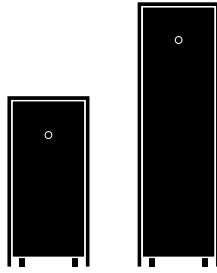

---

Cargo

132

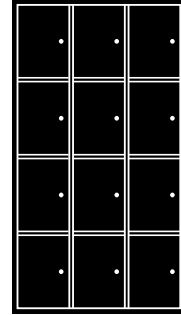

---

Lockers

140

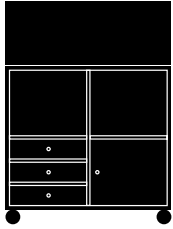

---

Office Selections

146



# Montana System

12 mm MDF / Design: Peter J. Lassen



## Storage Solutions

Montana gives you the freedom to create a personalised and functional space that perfectly fits your needs and style. With a wide range of modules, components, and colours, you can create your own unique storage solution – whether it's for the living room, office, bedroom, or hallway.

### Technical Information

The Montana System is made from 12 mm lacquered MDF and is available in 36 base modules with four different depths. The system's modules can be selected in all of Montana's lacquer colours, as well as two veneers.

# Montana Systems

---

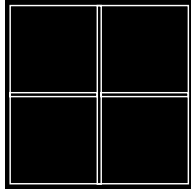

**Basic and Shelving Modules** 10

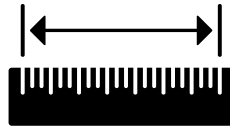

**Montana System  
Star System and Dimensions** 15

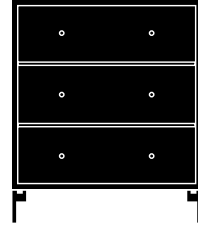

**Shelving Components** 17

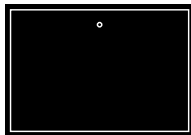

**SPECIAL MODUL**  
**Bar Unit and Secrétaire** 29



**SPECIAL MODUL**  
**Living Things** 30

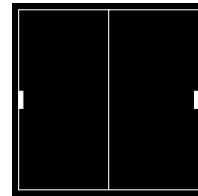

**SPECIAL MODUL**  
**Shelving Units with  
Sliding Doors** 32



**Surfaces** 33



**Load Capacity Overview** 34



# Montana System

EU ECOLABEL CERTIFIED

## Base and Shelving Modules

The following pages present an overview of the 36 base modules in the Montana System, as well as the system's standard positions. This is followed by an overview of a wide range of fully designed base modules with shelves, dividers, doors, trays, and more, which can serve as inspiration or a starting point. Additionally, by arranging the system's base modules and combining them, you can create exactly the configuration you desire.



### 36 basic modules

The Montana System consists of 36 basic modules in 4 depths. If you wish to design your personally arranged modules, the basic modules can be fitted with a wide range of different components.

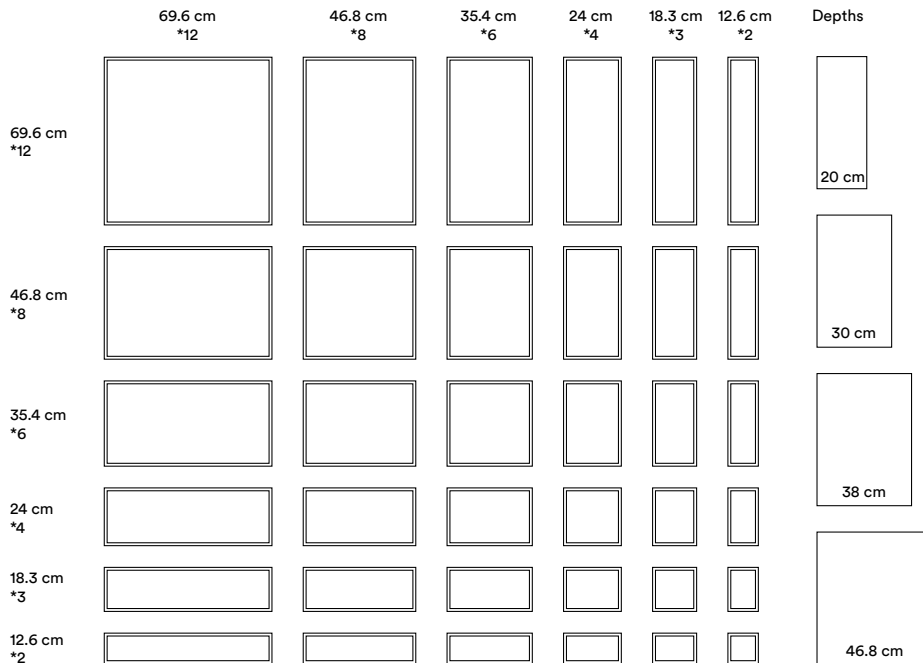

### Shelving modules

On the following pages, examples of arranged shelving modules are presented, which can be combined into configurations. The shelving modules can also be adapted to your individual wishes and needs by adding additional components.

An overview of all internal measurements and external measurements can be found on [page 15 >](#).

### Placement

The shelving modules are delivered assembled, ready to be placed on a plinth, legs, castors, base unit with castors, or equipped with suspension rail, ready for wall-mounting.

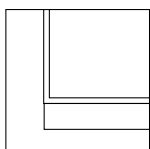

Plinth

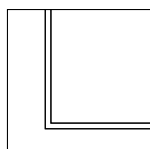

Suspension

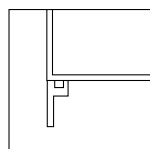

Legs

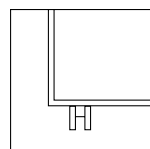

Castors

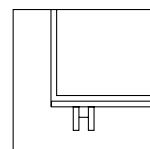

Base unit with castors



**P** Indicates that drawers/doors are without handles    **G** Indicates glass door with glass shelves    **R** Indicates rippled glass door with lacquered shelf behind the door

**Signatures** ▶

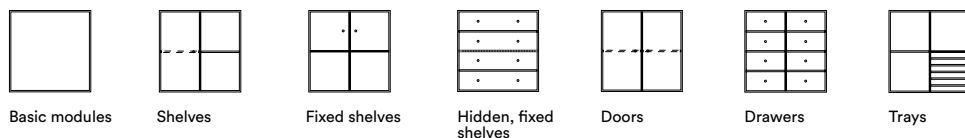



	46.8 cm *8	46.8 cm *8	46.8 cm *8	46.8 cm *8	35.4 cm *6	35.4 cm *6	35.4 cm *6	35.4 cm *6	35.4 cm *6	24 cm *4	18.3 cm *3	12.6 cm *2
69.6 cm *12												
69.6 cm *12												
69.6 cm *12												
46.8 cm *8												
35.4 cm *6												
24 cm *4												
18.3 *3												
12.6 *2												

**P** Indicates that drawers/doors are without handles    **G** Indicates glass door with glass shelves    **R** Indicates rippled glass door with lacquered shelf behind the door

**Signatures** ▶



Basic modules



Shelves



Fixed shelves



Hidden, fixed shelves



Doors



Drawers



Trays

## Good to know

Below is a range of information that may be useful to consider when choosing shelving modules. Modules are supplied as standard with aluminium handles. Additional charge for coloured handles.

## Modules depth 20 cm

Modules in D: 20 cm with doors are only sold with suspension rail. Remember the additional charge for suspension. Retrofitting doors to modules in D: 20 is done at your own risk.

## Support rail for shelving modules without vertical divider

The support rail SS10 for mounting under shelves and top in shelving modules without vertical divider must be selected when the load exceeds 3 kg. Shelves/top can carry a maximum load of 10 kg with the support rail. The rail is lacquered in the same colour as the shelving module.

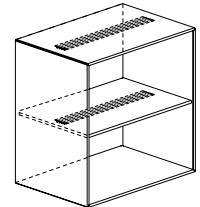

## Suspension types

- OP12 – standard suspension for modules H: 35.4 cm (\*6) to 69.6 cm (\*12) in all widths
  - OPSK – suspension with safety bracket for modules H: 12.6 cm (\*2) to \*4 in all widths
  - OPXS – reinforced metal suspension for modules H: 12.6 cm (\*2) and W: 46.8 cm (\*8) and 69.6 cm (\*12)
  - OPLYD – two-part suspension allowing cabling behind modules in 12 mm
  - OP12W – suspension for heavy modules, consisting of an OP12 and a supporting bracket
- OP12, OPSK can be combined with OPLYD 12 mm and OP12W

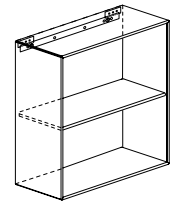

	69.6 cm *12	46.8 cm *8	35.4 cm *6	24 cm *4	18.3 cm *3	12.6 cm *2
OP12 ● .....						
69.6 cm *12						
46.8 cm *8						
35.4 cm *6						
OPSK ● .....						
24 cm *4						
18.3 cm *3						
12.6 cm *2						
OPXS ● .....						



## ★ Star system and dimensions

With Montana's star system, you can easily find modules and components that match in size. The table on the cover of the price list shows star measurements and the corresponding dimensions in cm.

### System

*Measurements	Internal	External
*1	4.5 cm	6.9 cm
*2	10.2 cm	12.6 cm
*3	15.9 cm	18.3 cm
*4	21.6 cm	24.0 cm
*5	27.3 cm	29.7 cm
*6	33.0 cm	35.4 cm
*7	38.7 cm	41.1 cm
*8	44.4 cm	46.8 cm
*9	50.1 cm	52.5 cm
*10	55.8 cm	58.2 cm
*11	61.5 cm	63.9 cm
*12	67.2 cm	69.6 cm

---

### Internal depth

When choosing Montana shelving modules, it can be practical to know the internal depth of open modules and the depth behind doors. The table below shows the internal measurements for the four module depths in the Montana System. Internal height and width measurements are provided alongside the modules in the price overviews.

Module depth	Internal measurements in open shelves	Internal measurements behind doors
20 cm	18.7 cm	16.1 cm
30 cm	28.7 cm	26.1 cm
38 cm	36.7 cm	34.1 cm
46,8 cm	45.5 cm	42.9 cm



## Generations – placement of shelves and dividers

When building a Montana module with components, it is important to account for different generations. Generation 0 is always the main corpus of the module. For each shelf or divider (generation) that is inserted, the depth of the component becomes smaller, as the component moves 5 mm further into the module from the edge.

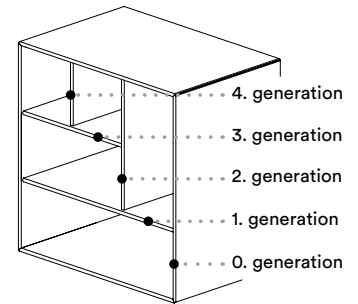

## \*6 + \*6 is not equal to \*12

When placing two modules with a height of \*6 (35.4 cm) on top of each other next to a module with a height of \*12 (69.6 cm), you will notice a difference of 12 mm, and they will therefore not align. See drawing example. For this reason, it is important to use the same number of modules both in height and width when creating a composition.

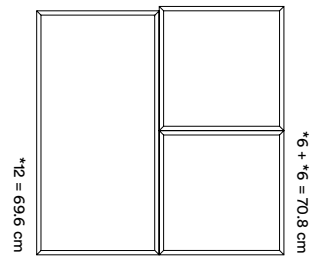

## The star system (\*1 = 5.7 cm)

Montana's star system makes it easy to combine modules and components. The unit of measurement 1 star (\*) = 5.7 cm indicates the distance between the pilot holes, which mark possible component positions. All Montana modules, with few exceptions, have these pilot holes.

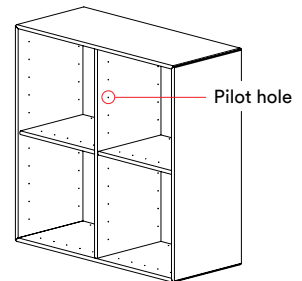

# Montana System

EU ECOLABEL CERTIFIED

## Shelving Components

With Montana's wide range of components, you have the freedom to customise your own shelving solution. Whether you start from scratch with a base module or wish to add new features to your existing storage, Montana gives you the flexibility to create a solution that fits your needs perfectly. Choose from shelves, drawers, doors, and special components to combine aesthetics and functionality in a timeless design that can be adapted to any home or workplace.



# Shelving components



## Shelves/dividers

The shelf is made of 12 mm lacquered or veneered MDF board. When ordering, please specify whether the shelf is to be used in an open module or behind a door, as well as which generation.

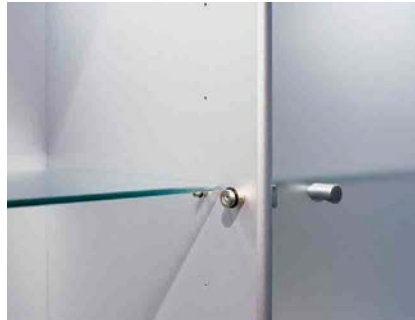

## Glas Shelves

4 mm hardened glass. Glass shelves have a fixed depth and can be used in open modules as well as behind a door.



## Protective Plastic for Shelves

**PLAST6:** Protective plastic sheet for shelves. Designed to prevent wear from binders. The protective sheet is transparent and placed loosely on the shelf. It can be adapted to shelves in open modules and shelves behind doors.



## Magazine Shelves

Inclined shelf with edge for magazines and brochures. The shelf is mounted on two pegs at the top and rests on the bottom or a fixed shelf below.

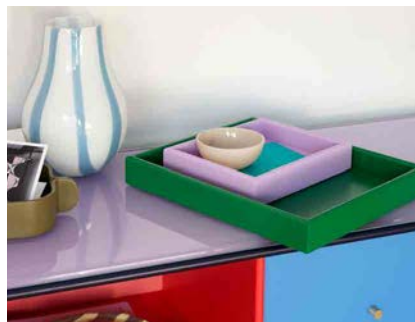

## Trays/Square Trays

**Trays:** 12 mm lacquered MDF.  
**Bottom:** 5.5 mm MDF. Mounted on tray runners in either black or white plastic, which are fixed in the pilot holes. Trays can be fully removed from the module.

For all dimensions and sizes: See overview on page 26 >



## Drawers/Drawers without Handles

**Drawer fronts:** 12 mm lacquered or veneered MDF board with white-pigmented drawer sides. Bottom: 4 mm white MDF board.

**Drawer extensions:** free-running extension in metal with soft-close and 100% extension. Additional price for coloured handle.

See internal measurements in the table on page 27 >



## Drawer Dividers

Drawer divider for drawers in W: 35.4 cm (\*6) and 69.6 cm (\*12) can be used for drawers in H: 12.6 cm (\*2) and 18.3 cm (\*3). The height of the divider is 5.5 cm.

# Shelving components



## Doors/doors without Handles

Modules in 20 cm depth with doors are only sold with mounted suspension rail. The door is made of 16 mm lacquered MDF. Remember the additional price for OP12. Retrofitting doors on modules in 20 cm depth is done at your own risk.



## Doors in Clear Glass

**Glass doors:** 4 mm hardened glass. An L-KIT must be used for mounting loose glass doors.



## Retractable Doors in Perforated Steel

Lacquered retractable door made of perforated steel and MDF.

The perforated retractable door can be mounted in modules with depths of 30 cm, 38 cm, and 46.8 cm.



## Doors – Lacquered Glass

**Glass doors:** 4 mm hardened glass. An L-KIT must be used for mounting loose glass doors. It is not recommended to use lighting behind lacquered glass doors.



## Doors – Rippled Glass

**Glass doors:** 4 mm hardened glass. An L-KIT must be used for mounting loose glass doors.



## Micro Powerdot

**POWERD:** Ø34 mm micro powerdot in white or black plastic. The powerdot is always placed at the top of the module, with the centre of the powerdot positioned 55 mm from the outer edge of the module, left/right placement. The cable exits at the back of the module. Compatible with USB-C plug.



## Handles

**G1:** Cylindrical with finger grip. L: 16 mm. Ø12 mm. Available in brushed aluminium, brass, and all lacquer colours.

**Screws:** For MDF door UH M4 × 20 mm

**Screws:** For glass door BH M4 × 10 mm



## Handles

**G7:** Montana handle with disc in clear polished acrylic. L: 16 mm. Ø12 mm. Available in aluminium and all lacquer colours.

**Screws:** For MDF door UH M4 × 20 mm

**Screws:** For glass door BH M4 × 10 mm

# Shelving components



## Plinths

Plinths are available as standard in heights of **3 cm** and **7 cm**. A plinth is fitted with 4 adjusting screws, allowing it to be levelled before placing the modules on top. The ends of the plinths are pre-drilled on the inside, so the hole can easily be drilled through when connecting in a row and stabilising sideways. During installation, anti-slip patches are placed between the plinth and the module. Installing plinths under modules in 20 cm depth with door is done at your own risk.

The effective plinth depths are 18 cm (D: 20 cm), 28 cm (D: 30 cm), 34 cm (D: 38 cm), and 44 cm (D: 46.8 cm). For special plinths, see the price list – contact a retailer. H3 plinth is adjustable by approx. 1.5 cm. H7 plinth is adjustable by approx. 2.7 cm.



## Legs

**H: 12.6 cm.** Height-adjustable up to 20 mm. Matt chromed zinc, brass, or lacquered in any of Montana's lacquer colours.

The legs can be mounted under modules from W: 24 cm (\*4) to W: 69.6 cm (\*12). Legs cannot be mounted under modules in D: 20 cm. Modules in W: 69.6 cm (\*12) must always be mounted with support rail SS60 under the bottom.

When ordering legs in connection with a module, the module is pre-drilled for leg mounting with euro screws. The legs can carry a load of max of 50 kg.



## Castors CR70

**CR70:** H: 6.8 cm, castor diameter Ø5.5 cm. Available in grey/black or black/black. Price per set of 4. Two of the castors are equipped with brakes. Modules in W: 69.6 cm (\*12) fitted with castors must have a support rail SS60 mounted. The castors can carry a load of max 80 kg.

Castors cannot be mounted under modules in D: 20 cm. CR70 castors cannot be mounted under shelving modules in W: 12.6 cm (\*2) and 18.3 cm (\*3).



## Castors SR

**H: 10 cm.** SR castors in grey rubber with brake. Price per set of 4. All 4 castors are equipped with brakes.

Modules in W: 69.6 cm (\*12) fitted with castors must have a support rail SS60 mounted. The castors can carry a load of max 80 kg. Castors cannot be mounted under modules in D: 20 cm.



## Castors CR

**H: 8.9 cm,** castor diameter Ø7.5 cm. Plastic castor with brake and soft tracking surface. Available in grey/black or black/black. The castors are equipped with brakes. CR: set of 4.

Modules in W: 69.6 cm (\*12) fitted with castors must have a support rail SS60 mounted. The castors can carry a load of max 80 kg. Castors cannot be mounted under modules in D: 20 cm.



## Castors SRCO

**H: 7,8 cm.** Plastic castors with brake and lacquered castor cover, available in all of Montana's lacquer colours. Price per set of 4. All 4 castors are equipped with brakes.

Modules in W: 69.6 cm (\*12) fitted with castors must have a support rail SS60 mounted. Castors cannot be mounted under modules in D: 20 cm. The castors can carry a load of max 70 kg.

# Shelving components



## Key Lock

**L1 Lock:** For doors and drawers

**L6 Lock:** For sliding doors

Can be ordered with different lock numbers/serial numbers. For re-orders, please specify the lock number/serial number.

When installing an L1 lock in a drawer, there must be a top panel/shelf above the drawer.

For lock accessories, see page 118 >



## Code Lock

**LCODE:** 4-digit code lock for doors and sliding doors. Available as Fixed or Free code.

A Fixed code is always the same and typically used by a single user.

A Free code is intended for environments where the cabinet is used temporarily, allowing free choice of doors.

For individual purchases, please specify whether the lock should be Free or Fixed, and whether it is to be mounted on a door or a sliding door. Both types of lock include an emergency opening function.

The product comes with a 1-year warranty.

For lock accessories, see page 119 >



## Electronic Battery Lock

**ELLOK** for modules with doors and sliding doors.

**ELLOK1:** For door

**ELLOK2:** For sliding door

Battery type: 1x CR123A

The battery lock is delivered in factory default mode and must be coded by the customer. The lock can be programmed with either a Fixed or Free code. The product comes with a 1-year warranty.

For lock accessories, see page 119 >



## Plinth Components

**SSKRUE:** Levelling screw for plinth. Levelling foot adjustment: H7 plinth approx. 2.7 cm, H3 plinth approx. 1.5 cm



## Connecting Screws

**KOBEL:** Connecting Screws, set of 10 pcs., includes both round-head and flat-head screws. Connecting screws are available for shelving units in 12 mm and 16 mm thickness.

Please specify the type when ordering.



## Support Rail

Support rail for module on castors or legs  
**SS60:** H: 2.5 cm x L: 60 cm or H: 4 cm x L: 60 cm

Modules with a width of 69.6 cm (\*12), fitted with castors or legs, must be equipped with the support rail SS60.

Supplied in the same colour as the module.

# Shelving components



## Cable Grommet in Back Panel / Cabinet

**KABELD:** Cable grommet, Ø60 mm, supplied in the same colour as the back panel. KABELD can be positioned at custom \*measurements in the back panel as desired. It can be rotated as needed. The grommet is press-fitted and mounted from the rear of the module.

**KABELT:** Cable grommet, Ø60 mm, supplied in the same colour as the cabinet. Round cut-out in the cabinet at the rear edge. The centre of the cable grommet is always placed either 55 mm from the module's outer side or centrally. This provides 12 possible positions.

If a module has a vertical divider in the centre or a centred horizontal shelf, it is not possible to place KABELT in the middle.



## Top Panels – 12 mm Glass

Glass tops (low iron) with a lacquered underside have a lighter shade compared to a lacquered MDF surface, as the lacquer colour is visible through the 12 mm glass.



## Top Panels – 12 mm MDF

12 mm MDF with water-based lacquer, standard measurements. Front and back edges: rounded. End edges: straight. When a top panel is to cover multiple modules, allow an additional 1 mm per module. Top panels are supplied with anti-slip pads.

**SAMNOT:** 12 mm top panels with special processing. Additional charge for jointing with tongue and groove. 1 = Tongue and groove at one end. 2 = Tongue and groove at both ends.



## Clothes Rail

**BS1312:** Clothes rail Ø13 mm in stainless steel. Measures 65.3 cm in width and 8.9 cm in height. Mounted beneath modules with a width of 69.6 cm (\*12).

Not suitable for use under modules with a depth of 20 cm.



## Clothes Rail

**BS1330:** Clothes rail Ø13 mm in stainless steel. Measures 21.3 cm in width and 8.9 cm in height. Mounted beneath modules with a width of 35.4 cm (\*6) and 46.8 cm (\*8), depth: 30 cm.



## Clothes Rail

**BS1338:** Clothes rail Ø13 mm in stainless steel. Measures 29.3 cm in width and 8.9 cm in height. Mounted beneath modules with a width of 35.4 cm (\*6) and 46.8 cm (\*8), depth: 38 cm.

# Shelving components



## LED Spotlight Integrated in Light Panel

**LED6L:** A 12V LED spotlight for 33 cm compartments (35.4 cm \*6), integrated into a 12 mm panel.

**LED8L:** A 12V LED spotlight for 44.4 cm compartments (46.8 cm \*8), integrated into a 12 mm panel.

**LED12L:** Two 12V LED spotlights for 67.2 cm compartments (69.6 cm \*12), integrated into a 12 mm panel.

The Montana System can be supplied with built-in 12V LED spotlights Ø55 in matt steel (12.4 watt).

The LED spotlight features an integrated dimming function, controlled via a switch. The switch is powered by kinetic energy and does not require a battery.

The LED light provides ambient lighting and can be adjusted from cool to warm light (Kelvin 2100K to 6500K). Colour Rendering Index (CRI) over 95. Lumen output: 160. Expected lifespan of an LED spotlight: approx. 30,000 hours.

The spotlights can be controlled via a WiFi Controller (Smart Life App, Alexa, Google Chrome, etc.). Remember to add the TLED12 transformer for 1–8 spotlights. Approved for CE and UKCA.

The products come with a 2-year warranty.



## Accessories for LED Spotlight

**LESPOT:** 12V built-in LED spotlight Ø55

**LEDF2:** 2-metre extension cable for LED spotlight

**TLED12:** Transformer for 1–6 light sources and switch, which can dim the light, turn it on/off, and adjust the ambient lighting – all without a battery

The products come with a 2-year warranty.



## Canvas Storage Boxes

**6161BO:** W: 32 cm x H: 31.5 cm x D: 27 cm (Compartment size: 35.4 cm (\*6) x 35.4 cm (\*6) x D: 30)

**7171BO:** W: 20.5 cm x H: 20 cm x D: 35 cm (Compartment size: 24 cm (\*4) x 24 cm (\*4) x D: 38)



## Touch-Up Lacquer

**REPLAK:** Lacquer for repairing small lacquer damages. Available in all Montana lacquer colours.



## Safety Bracket

**EQ12:** Safety bracket for earthquake protection of modules. Connects two modules side by side. The bracket is made of electro-galvanised steel.

# Shelving components



## Support Kit

Support kit for wall-mounted modules

**OP8W:** Aluminium bracket for installation beneath 12 mm modules without a vertical divider, with mounting brackets.

Included with modules: 1121/P, 1125/P, 1128/P, 1122/P, 1222/P, 1225/P, and 1525/P.

The kit includes a 42 cm support bracket, plugs, and screws.

Recommended as an individual purchase when retrofitting mounting brackets to the above modules.



## Connectors

**HMU:** 4 x connectors lacquered in the colour of the module's back panel, included with mounting brackets. Can also be ordered separately – please remember to specify the colour when purchased individually.



## Shelf Supports

**HB:** For MDF shelves. 2 x HB are used per shelf. Please specify depth when ordering HB.

10 cm shelf supports are used for shelves with a depth of 20 cm. 22 cm shelf supports are used for shelves with depths of 30, 38, and 46.8 cm.

**HBG:** For glass shelves. 4 pieces are used per shelf. Pack contains 1 piece.



## Mounting Bracket, Standard

**OP12:** Mounting bracket for 12 mm, available in various versions to fit all module sizes.

The bracket features horizontal adjustment and is supplied with fittings and spacers for wall adjustment.

It allows for cabling behind the module.



## Mounting Bracket with Safety Bracket

**OPSK:** Mounting bracket with safety bracket for modules with heights of 12.6 cm (\*2), 18.3 cm (\*3), and 24 cm (\*4) in all widths.

However, for height 12.6 cm (\*2), only suitable for modules with widths of 12.6 cm (\*2), 18.3 cm (\*3), 24 cm (\*4), or 35.4 cm (\*6).

The bracket features horizontal adjustment and is supplied with fittings and spacers for wall adjustment.

It allows for cabling behind the module.



## Reinforced Mounting Bracket

**OPXS:** Reinforced metal mounting bracket for modules with widths of 46.8 cm (\*8) and 69.6 cm (\*12), and a height of 12.6 cm (\*2).

The bracket features horizontal adjustment and is supplied with fittings and spacers for wall adjustment.

It allows for cabling behind the module.

# Shelving components



## Door Stop

**DS:** For MDF doors

**DSG:** For glass doors



## Hinges for Doors

**HT:** For MDF doors. Supplied as a set of two.

**HTG:** For glass doors. Available in aluminium and brass. Supplied as a set of two.



## Adjustable Spacer

**AFTDUP:** For use with mounting brackets. Black. Adjustable by 7 mm. Supplied as a set of two.



## Anti-Slip Pads

**SKLAP:** Ø20 mm anti-slip pad in silver. Anti-slip pads are used to secure stacked modules, as well as between plinth and module. Pack of 4.



## Drawer Runners

**UDTR:** Drawer runners for retrofitting drawers. Depth must be specified when ordering. Supplied as a set of two.



## Tray Rails

**BLIST:** Tray rail for mounting inside a module, fitted into the pre-drilled holes. Available in white and black.



## Glide Lists

**GLIST:** Glide lists for mounting underneath a tray, on a shelf, or on the module base.



## Shadow Lists

**SLIST:** Shadow list for drawers. Please specify width and colour when ordering.



## Tray Measurements / Square Trays

Here you can find all relevant measurements for trays in the 12 mm system.

### Trays height 4.2 cm (\*1)

Trays	Internal	External
Tray 41 D20	W: 18.9 x H: 2.9 x D: 14.9 cm	W: 21.3 x H: 4.2 x D: 17.3 cm
Tray 41 D30	W: 18.9 x H: 2.9 x D: 24.9 cm	W: 21.3 x H: 4.2 x D: 27.3 cm
Tray 61 D30	W: 30.2 x H: 2.9 x D: 24.9 cm	W: 32.6 x H: 4.2 x D: 27.3 cm
Tray 61 D38	W: 30.2 x H: 2.9 x D: 32.9 cm	W: 32.6 x H: 4.2 x D: 35.3 cm
Tray 81 D30	W: 41.7 x H: 2.9 x D: 24.9 cm	W: 44.1 x H: 4.2 x D: 27.3 cm
Tray 81 D38	W: 41.7 x H: 2.9 x D: 32.9 cm	W: 44.1 x H: 4.2 x D: 35.3 cm

### Trays height 10.1 cm (\*2)

Trays	Internal	External
Tray 62B D30	W: 30.2 x H: 9 x D: 24.9 cm	W: 32.6 x H: 10.1 x D: 27.3 cm
Tray 62B D38	W: 30.2 x H: 9 x D: 32.9 cm	W: 32.6 x H: 10.1 x D: 35.3 cm
Tray 62B D46	W: 30.2 x H: 9 x D: 41.7 cm	W: 32.6 x H: 10.1 x D: 44.1 cm

### Square trays height 15.6 cm (\*3)

Trays	Internal	External
Tray 33 D30	W: 13.2x H: 14.5 x D: 24.9 cm	W: 15.6 x H: 15.6 x D: 27.3 cm
Tray 33 D38	W: 13.2x H: 14.5 x D: 32.9 cm	W: 15.6 x H: 15.6 x D: 35.3 cm

### Square trays height 21.5 cm (\*4)

Trays	Internal	External
Tray 44 D30	W: 18.9 x H: 20.4 x D: 24.9 cm	W: 21.3 x H: 21.5 x D: 27.3 cm
Tray 44 D38	W: 18.9 x H: 20.4 x D: 32.9 cm	W: 21.3 x H: 21.5 x D: 35.3 cm



## Drawer Measurements

Here you can find all relevant measurements for drawers in the 12 mm system.

### Internal Drawer Measurements (Usable Space)

Drawer	W x H	Depth 30	Depth 38	Depth 46
Drawer 62 / 62P	W: 29.7 x H: 6.6 (5) cm	23.3 cm	31.3 cm	40.1 cm
Drawer 82 / 82P	W: 41.1 x H: 6.6 (5) cm	23.3 cm	31.3 cm	40.1 cm
Drawer 122 / 122P	W: 63.9 x H: 6.6 (5) cm	23.3 cm	31.3 cm	40.1 cm
Drawer 63 / 63P	W: 29.7 x H: 12.3 (10.8) cm	23.3 cm	31.3 cm	40.1 cm
Drawer 83 / 83P	W: 41.1 x H: 12.3 (10.8) cm	23.3 cm	31.3 cm	40.1 cm
Drawer 123 / 123P	W: 63.9 x H: 12.3 (10.8) cm	23.3 cm	31.3 cm	40.1 cm
Drawer 64 / 64P	W: 29.7 x H: 18 (10.8) cm	23.3 cm	31.3 cm	40.1 cm
Drawer 84 / 84P	W: 41.1 x H: 18 (10.8) cm	23.3 cm	31.3 cm	40.1 cm
Drawer 124 / 124P	W: 63.9 x H: 18 (10.8) cm	23.3 cm	31.3 cm	40.1 cm
Drawer 66SK / 66SKP	W: 29.7 x H: 29.2 (27.7) cm		31.3 cm	40.1 cm

Height measurements are from the drawer base to the top drawer front; measurements in parentheses indicate the height of the sides and back panel.

With shadow list: add 1.2 cm to the height.

Pen trays 31PR and 61PR have a white-lacquered tray made of 22 mm MDF, with compartments of various sizes for storing writing instruments.



# Special Modules

EU ECOLABEL CERTIFIED

## Bar Module and Desk Module

The bar and desk modules from Montana function as both ideal storage for bottles and drinkware and as a practical home office, where the laptop can be stored behind the door when the workday is over.

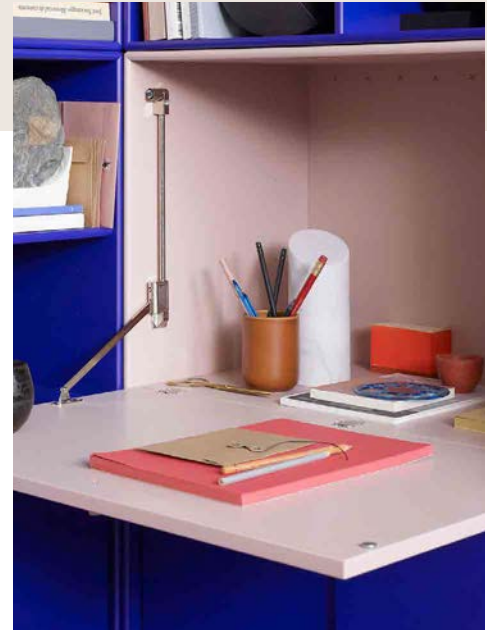

### Technical Information: Bar Module and Desk Module

The modules can be wall-mounted individually or combined with other modules. They are always supplied with mounting brackets and must be fixed to the wall.

**Desk Module:** A shelf can be mounted behind the door in the desk module at 12.6 cm (\*2), 24 cm (\*4), 29.7 cm (\*5), or 35.4 cm (\*3) from the top in a depth of 38 cm. Please note that the shelf must be shortened due to the flap fitting and is mounted using glass shelf supports (pins).

**Bar Module:** Internally fitted with a mirrored back panel and black glass panel on the bottom and flap. An LED spotlight is mounted inside the module; the cable and transformer are concealed in the back panel. Delivered with a light switch.

**Bar and Desk Modules:** These modules are supplied only with wall mounting to prevent tipping – this applies to both the bar module and the desk module.

The door must not be loaded with more than 10 kg.

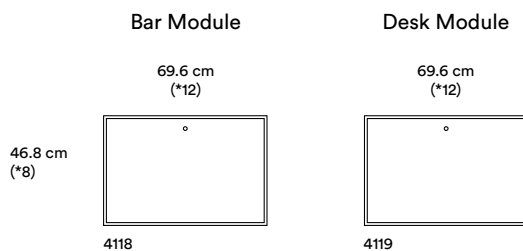

Internal Measurements – Bar Module:

Cabinet depth	Behind door
30 cm	22.5 cm
38 cm	30.5 cm

Internal Measurements – Desk Module:

Cabinet depth	Behind door
30 cm	25.5 cm
38 cm	33.5 cm

# Special Modules

EU ECOLABEL CERTIFIED

## Living Things

Living Things plant and storage boxes are available in eight different sizes and come with or without a divider, so the modules can be used for both plants and magazines, for example.

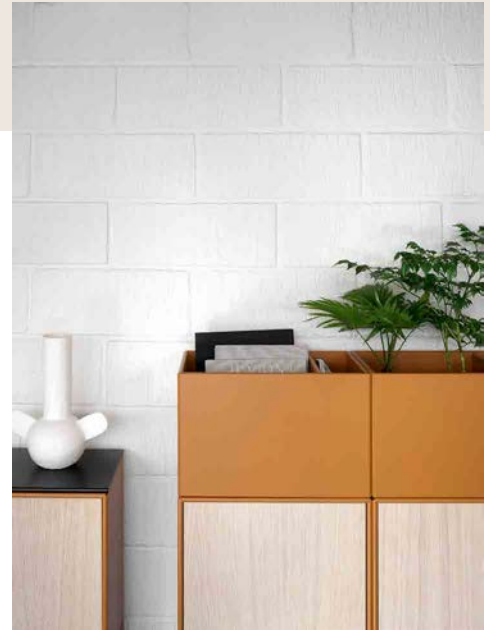

---

### Technical Information

Living Things is supplied with transparent protective plastic in the bottom. If the module is used for plants, it is recommended that they are placed in a waterproof saucer. Any spilled water inside the module must be wiped off immediately.

To allow placement on top of configurations, the module is made with a podium base and comes with 8 transparent pads (Ø10 × 3 mm). Cannot be mounted with wall brackets or placed on a plinth. Maximum load: 15 kg.

# Living Things overview

---

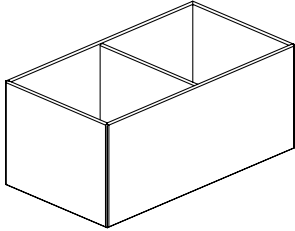

W (\*12)

**LT3812**

W 69.6 x H 30 x D 38 cm  
Internal space: W 33/33 x H 28.7 x D 35.6 cm

---

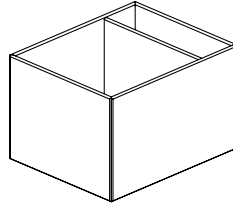

W (\*8)

**LT3842**

W 46.8 x H 30 x D 38 cm  
Internal space: W 33/10.2 x H 28.7 x D 35.6 cm

---

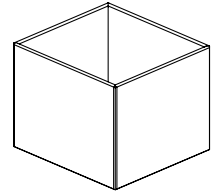

W (\*6)

**LT3861**

W 35.4 x H 30 x D 38 cm  
Internal space: W 33 x H 28.7/18.7 x D 35.6 cm

---

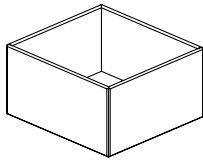

W (\*6)

**LT3861**

W 35.4 x H 20 x D 38 cm  
Internal space: W 33 x H 28.7/18.7 x D 35.6 cm

---

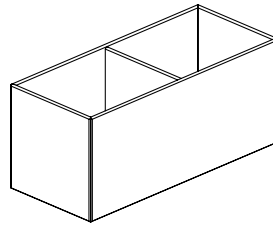

W (\*12)

**LT3012**

W 69.6 x H 30 x D 30 cm  
Internal space: W 33/33 x H 28.7 x D 27.6 cm

---

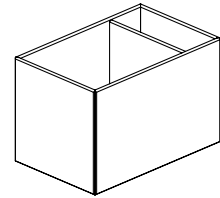

W (\*8)

**LT3042**

W 46.8 x H 30 x D 30 cm  
Internal space: W 33/10.2 x H 28.7 x D 27.6 cm

---

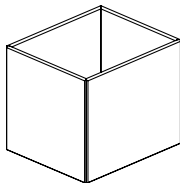

W (\*6)

**LT3061**

W 35.4 x H 30 x D 30 cm  
Internal space: W 33 x H 28.7 x D 27.6 cm

---

# Special Modules

EU ECOLABEL CERTIFIED

## Modules with Sliding Doors

Modules with sliding doors are practical and space-saving. The sliding door easily glides to the side, providing quick access to the module's contents. Sliding doors are available only for specific module sizes.



### Technical Information

#### Shelving Modules with Sliding Doors

Shelving modules with sliding doors and metal flat handles. The doors can slide together on either the left or right side of the module. The modules have a vertical divider placed in the centre, behind the sliding doors.

Shelves in shelving modules with sliding doors in depths of 20 cm and 30 cm are fixed in place. It is not possible to retrofit shelves in the 20 cm and 30 cm depths. The effective shelf depths in sliding door modules are: 13.2 cm (D: 20), 23.3 cm (D: 30), 31.3 cm (D: 38), and 40 cm (D: 46.8).

Sandwich handles are only available in aluminium.

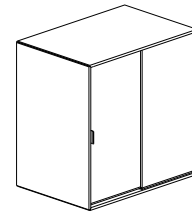

#### Locking Systems

L6 lock for sliding doors. System lock compatible with L1. Locks by pressing in the lock core and turning it.

See page 21 under shelving components >

# Montana System surfaces

## Materials

The bar module/desk module is available in Montana's lacquer colours. The bar module with flap is internally fitted with a mirrored back panel and a black glass panel on the bottom of the module.

**Living Things:** Available in all Montana lacquer colours

**Modules with Sliding Doors:** Available in all Montana lacquer colours.

## Lacquered MDF

Montana's lacquer colours



\*Veneer surfaces are available in a limited range – see the price list or Design Pro.

Please note that printed colours may differ from the original colour.

# Load Capacity Overview — modules

Mounted shelving units with heights in multiples of \*12, \*8, and \*6 and depths of 20, 30, and 38 cm can support a load of up to 40 kg, provided the wall composition and the mounting method allow for it.

Shelving units with heights in multiples of \*4, \*3, and \*2 and a depth of 46.8 cm have a lower weight capacity and should only be loaded with up to 10 kg.

Please note that units with a width of \*12, without a vertical partition, can only support a load of 3 kg unless a support rail (SS10) is used. Similarly, shelves with the same width can only support a load of 3 kg without the use of a support rail SS10.

## Load capacity for modules on suspension rail

Height	Width	*12 with vertical partition 69.6 cm	*12 without vertical partition 69.6 cm with support rail SS10	*8 46.8 cm	*6 35.4 cm	*4 24 cm	*3 18.3 cm	*2 12.6 cm
*6, *8, *12	D20	40 kg	10 kg					
	D30							
	D38							
	D46,8	20 kg						
*2, *3, *4	D20	10 kg						
	D30							
	D38							
	D46,8		10 kg					

## Load capacity for modules on plinth

Height	Width	*12 with vertical partition 69.6 cm	*12 without vertical partition 69.6 cm with support rail SS10	*8 46.8 cm	*6 35.4 cm	*4 24 cm	*3 18.3 cm	*2 12.6 cm
*6, *8, *12	D20	60 kg	10 kg					
	D30							
	D38							
	D46,8	40 kg						
*2, *3, *4	D20	40 kg						
	D30							
	D38							
	D46,8		40 kg					

# Load Capacity Overview — modules

## Load capacity for modules on legs - max. load for one set of legs: 75 kg

Height	Width	*12 with vertical partition and SS60 69.6 cm	*12 without vertical partition 69.6 cm with support rail SS10	*8 46.8 cm	*6 35.4 cm	*4 24 cm	*3 18.3 cm	*2 12.6 cm
*2, *3, *4, *6, *8, *12	D20	50 kg	10 kg	50 kg				
	D30							
	D38							
	D46.8							

## Load capacity for modules on castors

Height	Width	*12 with vertical partition and SS60 69.6 cm	*12 without vertical partition 69.6 cm with support rail SS10	*8 46.8 cm	*6 35.4 cm	*4 24 cm	*3 18.3 cm	*2 12.6 cm
*2, *3, *4, *6, *8, *12	D20	80 kg	10 kg	80 kg				
	D30							
	D38							
	D46.8							



# TV & Sound

12 mm MDF / Design: Peter J. Lassen



## TV Stands and Sideboards

With TV & Sound, you can create the optimal storage for electronics and hi-fi equipment. A solution that hides cables, digital boxes, and other electronic devices.

### Technical Information

TV & Sound modules are available in depths of 30 cm and 38 cm. The modules are designed with a perforated retractable metal door, allowing operation of the electronics even when the door is closed. Additionally, the modules are equipped with both internal cable grommets and cable outlets on the back, ensuring flexible and discreet cabling. The modules are available in lengths designed to fit modern flat-screen TVs, so they blend harmoniously into the decor. Standard delivery includes aluminium handles, with coloured or brass handles available at an extra cost.

### Load Capacity

TV & Sound modules with a depth of 30 cm and 38 cm can support up to 40 kg evenly distributed. The module top can support a maximum of 20 kg; however, tops and shelves in the 69.6 cm (\*12) size without a vertical divider can support a maximum of 10 kg.

### Mounting

TV & Sound modules can be mounted on plinths, legs, or castors – or when fitted with wall mounting brackets, they can be mounted on the wall. The only exception is the Sound modules in 183.6 cm (\*32), which cannot be mounted on castors. Sound modules in 183.6 cm (\*32) are supplied with 6 legs. Sound modules in widths of 183.6 cm (\*32) and 138 cm (\*24) must be equipped with 2 OP12 brackets when selected with wall mounting. The brackets allow cabling to be routed behind the modules.

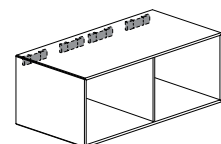
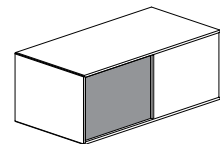

# TV & Sound overview

Depth 30/38 cm

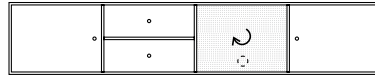
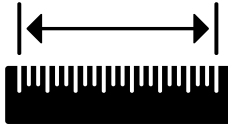

H: 34,4 cm (\*6) / H: 24 cm (\*6)

H: 34,4 cm (\*6)

**TV & Sound** 38  
**Star System and Dimensions**

**Pre-designed** 40

**Design your Own** 41



H: 24 cm (\*6)

**Design your Own** 42

**Components** 43

**Surfaces** 45

## Good to Know

Below is a selection of information that may be helpful to consider when choosing TV & Sound.

### TV & Sound Modules

*Measurements	*4	*6	*12	*16	*20	*24	*32
Internal	21.6 cm	33.0 cm					
External	24.0 cm	35.4 cm	69.6 cm	92.4 cm	115.2 cm	138.0 cm	183.6 cm

### Internal Measurements

Below are the internal measurements behind the retractable door/perforated retractable door, which may be important to know when planning storage for your hi-fi equipment.

Depth	Open module	Behind doors	Behind retractable doors (KLS)
30 cm	28.7 cm	26.1 cm	25.8 cm
38 cm	36.7 cm	34.1 cm	33.8 cm
46 cm*	45.5 cm	42.9 cm	42.6 cm

\* Limited range in D: 46 cm

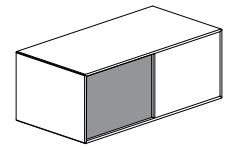

### Module Size

Below is an illustration of how the TV & Sound modules fit various TV sizes.

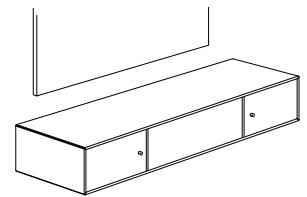
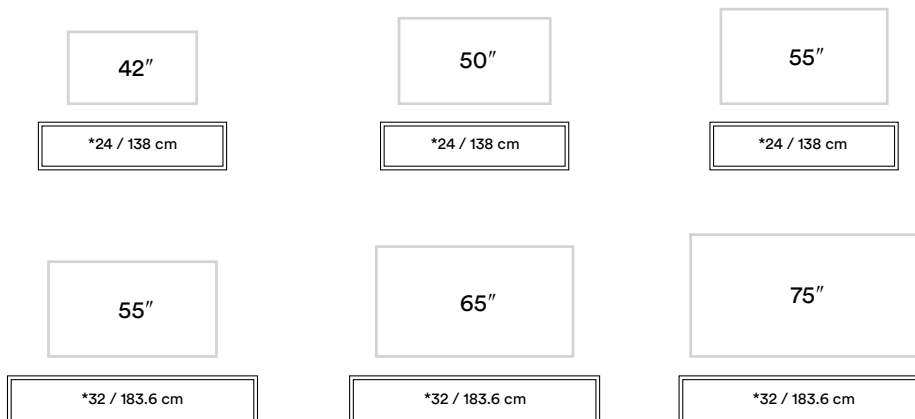



### Cable Grommet and Shelves with Cut-Outs

The back panel is fitted with a round cut-out for the KABELD cable grommet, allowing cables to exit the module for power connection. KABELD has a fixed position. If additional cable grommets are required in the back panel, they can be purchased separately. The cable grommet matches the colour of the back panel. Shelves/dividers for TV & Sound modules (XTS shelves) feature a rear cut-out for cable management, measuring W: 4 cm x D: 5 cm. The cut-out is always positioned to the right or near the bottom of the shelf/divider, and sits 2 cm from the edge.

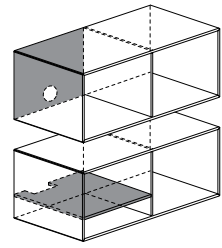

### Perforated Retractable Door

A perforated retractable door discreetly conceals electronic equipment. The door front is made of perforated steel, lacquered in Montana's lacquer colours. The door has no handle and is opened by lightly pressing the lower part, which then slides up beneath the top of the module.

The perforated retractable door allows operation of electronic devices while the door is closed and improves air circulation around hi-fi equipment. Shelves above, below, and between retractable doors are fixed in place. When the retractable door is open, it takes up 3.2 cm from the internal top down into the module.

Internal depth measurements behind the retractable door are: 6.1 cm (D: 30), 34.1 cm (D: 38), 42.9 cm (D: 46.8). Retrofitting is possible but done at your own risk.

Modules fitted with KLS126 and KLS124 must be mounted with an SS10 support rail beneath the top of the module.

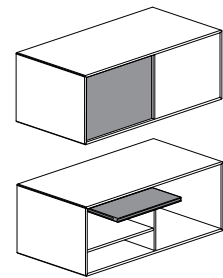

### Support Rail

VI10, VI18, VE11, VE15, SI13, and SE15 are fitted with a colour-matched SS89 support rail beneath the base when selected with wall mounting.

The SS10 support rail must be added beneath extra shelves and tops measuring 69.6 cm (\*12) if the load exceeds 3 kg. Shelves/tops can support a maximum load of 10 kg. Support rails are lacquered in the same colour as the shelving module.

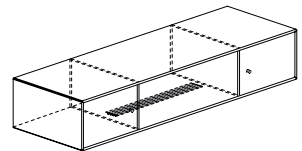

# TV & Sound pre-designed

Examples of Pre-Designed TV & Sound Modules

Depth 30/38 cm

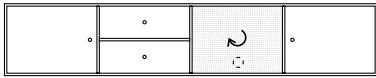

(\*32 x \*6)

SE13/SE13P

183.6 x 35.4 cm

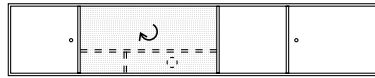

(\*32 x \*6)

SE15/SE15P

183.6 x 35.4 cm

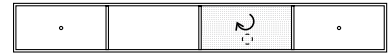

(\*32 x \*4)

VE13/VE13P

183.6 x 24 cm

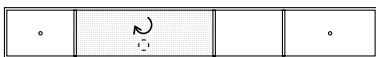

(\*32 x \*4)

VE15/VE15P

183.6 x 24 cm

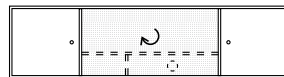

(\*24 x \*6)

SI13/SI13P

138 x 35.4 cm

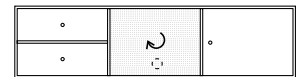

(\*24 x \*6)

SI16/SI16P

138 x 35.4 cm



(\*24 x \*4)

VI14/VI14P

138 x 24 cm



(\*24 x \*4)

VI18/VI18P

138 x 24 cm

## Signatures ►



Cable Grommet



Perforated Retractable Door and Shelf Behind Retractable Door



# TV & Sound design your own

Design your own module by selecting a base size and adding doors, drawers, retractable doors, etc.  
 Modules with a height of 34.4 cm (\*6).

Depth 30/38 cm

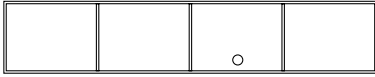

(\*32 x \*6)

**SE10**

183.6 x 35.4 cm

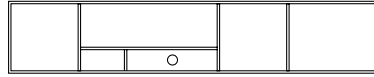

(\*32 x \*6)

**SE11**

183.6 x 35.4 cm

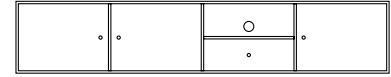

(\*32 x \*6)

**SE14/SE14P**

183.6 x 35.4 cm

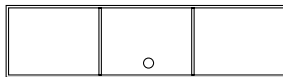

(\*24 x \*6)

**SI09**

138 x 35.4 cm

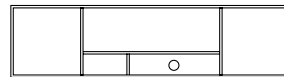

(\*24 x \*6)

**SI11**

138 x 35.4 cm

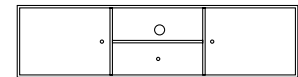

(\*24 x \*6)

**SI17/SI17P**

138 x 35.4 cm



(\*12 x \*6)

**T6112**

69.6 x 35.4 cm



(\*12 x \*6)

**T6217**

69.6 x 35.4 cm



(\*8 x \*6)

**T6141**

46.8 x 35.4 cm

Signatures ►



Cable Grommet



# TV & Sound design your own

Design your own module by selecting a base size and adding doors, drawers, retractable doors, etc.  
Modules with a height of 24 cm (\*4).

Depth 30/38 cm

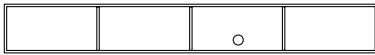

(\*32 x \*4)

VE10

183.6 x 24 cm



(\*32 x \*4)

VE11

183.6 x 24 cm



(\*32 x \*4)

VE14/VE14P

183.6 x 24 cm

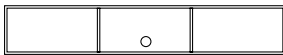

(\*24 x \*4)

VI09

138 x 24 cm

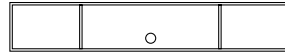

(\*24 x \*4)

VI10

138 x 24 cm

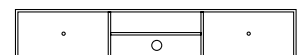

(\*24 x \*4)

VI15/VI15P

138 x 24 cm

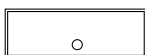

(\*12 x \*4)

T7111

69.6 x 24 cm



(\*12 x \*6)

T7112

69.6 x 24 cm

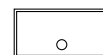

(\*8 x \*4)

T7141

46.8 x 24 cm

Signatures ►



Cable Grommet

# TV & Sound components



## Shelves/Dividers

**XTS shelves** feature a cut-out for cables at the rear edge of the shelf/divider, measuring

W: 4 cm x D: 5 cm.

The cut-out is always positioned to the right or towards the bottom of the shelf.

The cut-out is located 2 cm from the edge.



## Retractable Steel Doors

Lacquered retractable door made of perforated steel with an internal MDF frame.

The retractable door can be mounted on modules with depths of 30 cm, 38 cm, and 46.8 cm.

The internal depth measurements behind the retractable door are: 26.1 cm (D: 30), 34.1 cm (D: 38), 42.9 cm (D: 46.8). Retrofitting is possible but done at your own risk.

Modules fitted with **KLS126** and **KLS124** must be mounted with an **SS10 support rail** beneath the top of the module.



## Doors

16 mm lacquered MDF board or veneered MDF board with coloured edges.

Supplied with or without handles, with an additional cost for lacquered handles.



## Drawers

**Drawer fronts:** 12 mm lacquered or veneered MDF board with white-pigmented drawer lining. Base: 4 mm white MDF board.

**Drawer runners:** Smooth-running metal extension with soft-close and 100% extension. Supplied with or without handles, with an additional cost for lacquered handles.



## 12 mm Mounting Bracket

A 12 mm depth mounting bracket that allows for cable routing behind the module. The 12 mm mounting bracket accommodates cables up to Ø8 mm.

The OPLYD mounting bracket is split into two parts for modules with widths from 46.8 cm (\*8) to 138 cm (\*24).

Modules with widths of 12.6 cm (\*2), 18.3 cm (\*3), 24 cm (\*4), 35.4 cm (\*6), and 41.1 cm (\*7) have a standard wall bracket and are not split.

Two mounting brackets are required for TV & Sound modules with widths of 138 cm (\*24) and 183.6 cm (\*32). Modules with a height of 24 cm (\*4) are equipped with a safety bracket.

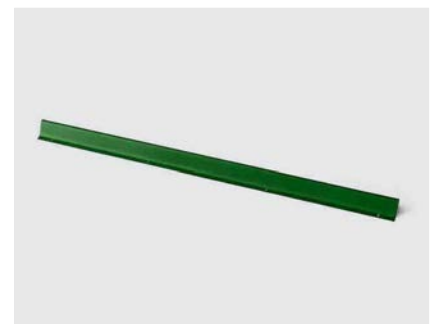

## Support Rail

The **SS10 support rail** can, for an additional cost, be mounted in open modules with a width of 69.6 cm (\*12) without a vertical divider. The support rail is supplied in the same colour as the shelving modules.

Shelves/tops can support a maximum of 10 kg with the support rail.

In modules with a width of 69.6 cm (\*12) without a vertical divider, the module top can be fitted with the SS10 support rail to increase the load capacity by 10 kg.

# TV & Sound components



## Cut-Out in Back Panel

**KABELD:** Cable grommet, Ø60 mm. The plastic cover is generally supplied in a colour that matches the back panel. It can be placed at custom \*measurements in the back panel as desired.

KABELD and KABELT can be rotated as needed. They can be pushed through and mounted from the rear of the module.



## Plinths H: 3 cm

**603:** Plinth for modules with a width of 35.4 cm (\*6).

**803:** Plinth for modules with a width of 46.8 cm (\*8).

**1203:** Plinth for modules with a width of 69.6 cm (\*12).

**2403:** Plinth for modules with a width of 138 cm (\*24).

**3203:** Plinth for modules with a width of 183.6 cm (\*32).

The effective plinth depths are: 28 cm (D: 30 cm) and 34 cm (D: 38 cm).



## Plinths H: 7 cm

**607:** Plinth for modules with a width of 35.4 cm (\*6)

**807:** Plinth for modules with a width of 46.8 cm (\*8)

**1207:** Plinth for modules with a width of 69.6 cm (\*12)

**2407:** Plinth for modules with a width of 138 cm (\*24)

**3207:** Plinth for modules with a width of 183.6 cm (\*32)

The effective plinth depths are: 28 cm (D: 30 cm) and 34 cm (D: 38 cm).



## Leg

**H: 12.6 cm.** Height can be adjusted up to 20 mm. Matt chrome-plated zinc, brass, or lacquered in one of Montana's lacquer colours. The legs can support a maximum of 50 kg. The legs are equipped with discreet leveling feet. Modules with widths of 69.6 cm (\*12), 138 cm (\*24), and 183.6 cm (\*32) must always have the support rail mounted.

**MB126:** Price for a set of 4 legs.

**MB1266:** Price for a set of 6 legs. Used for modules with a width of 183.6 cm (\*32).



## Support Rail

**SS60:** Support rail for modules with a width of 69.6 cm (\*12) with castors and legs.

**SS24:** Support rail for modules with a width of 138 cm (\*24) and 183.6 cm (\*32) with castors and legs.

Modules with a width of 183.6 cm (\*32) are not available with castors.



## Castors

All castors are supplied in sets of 4. See castor types under Shelving Components on page 20.

Sound modules with a width of 183.6 cm (\*32) are not available with castors.

Modules with widths of 69.6 cm (\*12), 138 cm (\*24), and 183.6 cm (\*32) must always have the support rail mounted.

# TV & Sound surfaces

## Materials

Modules: 12 mm MDF in all of Montana's lacquer colours.

## Lacquered MDF

TV & Sound models are available in all of Montana's lacquer colours.



## Legs

Available in all of Montana's lacquer colours, matt chrome-plated zinc, and brass.

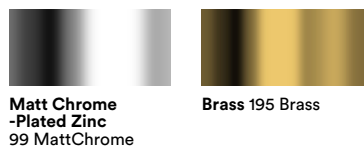



# System Seating

12 mm MDF / Design: Peter J. Lassen



## Benches with Storage

Create a flexible layout with Montana System Seating. Montana System Seating consists of seating with integrated storage options such as drawers, cabinets, and shelves under the seating surface, as well as plant boxes on top of the taller modules.

### Technical Information

System Seating is a category of shelving units that can be combined into benches. The models are 69.6 cm (\*12) in width and 35.4 cm (\*6) in height, made from 12 mm MDF, available in all of Montana's lacquer colours. The modules are offered with a plinth height of 3 or 7 cm. System Seating includes a component section that allows you to build your own bench.

A bench can support up to 150 kg and is available in 3 depths: 30, 38, and 46.8 cm. However, the 66SK/66SKP drawer is not available in D: 30, as part of the following modules: 62226/6226P, 6126/6126P, 6228/6228P, and 1464/1464P. See the overview on the following pages.

Coloured and brass handles are available at an additional cost.

# System Seating overview

Depth 30/38/46,8 cm.

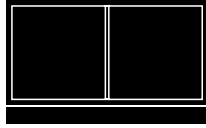

(\*12 x \*6)

Module size 69.6 x 35.4 cm 48

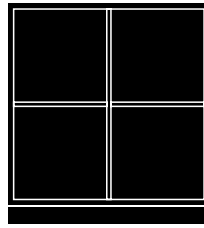

(\*12 x \*12)

Module size 69.6 x 69.6 cm 48

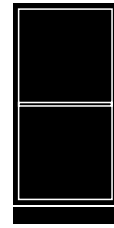

(\*6 x \*12)

Module size 35.4 x 69.6 cm 49



Components 50



Surfaces 53



# System Seating

Modules in width 69,6 cm (\*12)

Depths 30/38/46,8 cm



(\*12 x \*6)

**6112** 69.6 x 35.4 cm



(\*12 x \*6)

**6114** 69.6 x 35.4 cm



(\*12 x \*6)

**6312** 69.6 x 35.4 cm



(\*12 x \*6)

**6224/6224P** 69.6 x 35.4 cm



(\*12 x \*6)

**6324/6324P** 69.6 x 35.4 cm



(\*12 x \*6)

**6226/6226P** 69.6 x 35.4 cm

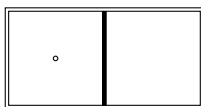

(\*12 x \*6)

**6126/6126P** 69.6 x 35.4 cm

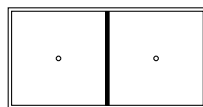

(\*12 x \*6)

**6228/6228P** 69.6 x 35.4 cm

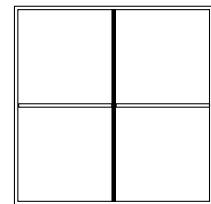

(\*12 x \*12)

**1112** 69.6 x 69.6 cm

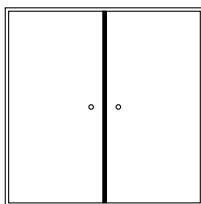

(\*12 x \*12)

**1118/1118P** 69.6 x 69.6 cm

## Signatures ►



Shelves



Fixed shelves



Doors



Drawers

P indicates that drawers/doors are handle-free with push.

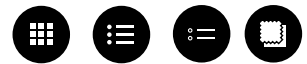

# System Seating

Modules in width 35,4 cm (\*6)

Depths 30/38/46,8 cm

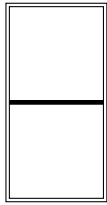

(\*6 x \*12)

**1261**

35.4 x 69.6 cm

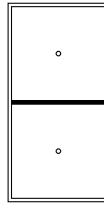

(\*6 x \*12)

**1464/1464P**

35.4 x 69.6 cm

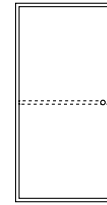

(\*6 x \*12)

**1162/1162P**

35.4 x 69.6 cm

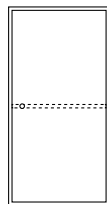

(\*6 x \*12)

**1165/1165P**

35.4 x 69.6 cm

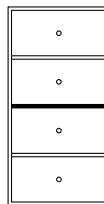

(\*6 x \*12)

**1363/1363P**

35.4 x 69.6 cm

## Signatures ►



Shelves



Fixed shelves



Doors



Drawers

P indicates that drawers/doors are handle-free with push.

# System Seating

EU ECOLABEL CERTIFIED

## Components

Build your own System Seating and add components such as shelves, doors, planter boxes (Living Things), or cushions. The cushion is made from high-quality materials that ensure both durability and lasting comfort. It features a non-slip underside and a practical zipper, which keeps it in place and makes it easy to remove the cover for cleaning.



---

### Technical Information

The cushion is available in a selection of textiles and colours, allowing it to be customised to your personal style. The standard model is upholstered with Reflect by Kvadrat, made from 100% recycled polyester, and comes in four colours.

The foam is 5 cm thick, and the cover is recommended to be dry cleaned.

Cushions are produced with a tolerance of  $\pm 1.0$  cm in width and depth.

The cushion is available in a selection of 4 standard textiles; fabrics outside the standard range can be purchased at an additional cost.

# System Seating components

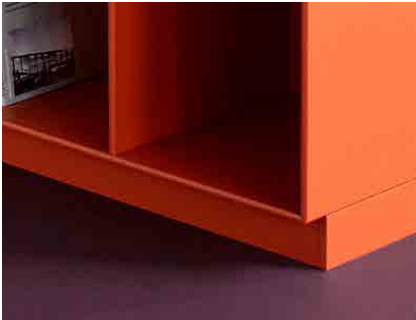

## Plinths

A plinth is equipped with 4 leveling screws, allowing it to be levelled before the modules are placed on top.

The ends of the plinths are pre-drilled inside, so the hole can be easily drilled through the plinth when connecting them in a row and stabilising them sideways.

The effective plinth depths are: 28 cm (D: 30 cm), 34 cm (D: 38 cm), and 44 cm (D: 46.8 cm).



## Drawers/Shelves/Dividers/Doors

**Doors:** 16 mm lacquered MDF board or veneered MDF board with coloured edges.

**Shelves:** X indicates that the shelf is made from 12 mm lacquered or veneered MDF board.

When ordering, please specify whether the shelf is to be used in an open shelving unit or behind a door.

**Drawers:** Drawer fronts: 12 mm lacquered or veneered MDF board with white-pigmented drawer lining. Base: 4 mm white MDF board.

**Drawer runners:** Smooth-running metal extensions with soft-close and 100% extension. P indicates that doors are available handle-free. Handle-free fronts cannot be mounted with locks.



## Living Things

**LT3861:** W: 35.4 cm (6\*) x H: 30/20 cm.

Internal usable space: W: 33 cm x H: 28.7/18.7 cm x D: 35.6 cm.

**LT3812:** W: 69.6 cm (12\*) x H: 30 cm.

Internal usable space: W: 67.2 cm x H: 28.7 cm x D: 35.6 cm.

Living Things is supplied with transparent protective plastic in the bottom. If the module is used for plants, it is recommended that plants be placed in a waterproof saucer, and any spilled water in the module should be wiped off immediately. To allow the module to be placed on top of configurations, it is made with a podium base and supplied with 8 transparent pads Ø10 x 3 mm.

**Maximum load:** 15 kg.

Cannot be mounted with wall mounting brackets.



## Cushions

Cushions made from 5 cm foam with a non-slip underside. Upholstered with Reflect by Kvadrat in 4 colours: 404, 614, 344, & 184 in 100% recycled polyester. The cover is removable and is recommended to be dry cleaned. Cushions are produced with a tolerance of ±1.0 cm in width and depth.

**CUS069:** W: 69 x H: 5 x D: 38 cm.

**CUS139:** W: 138 x H: 5 x D: 38 cm.

**CUS208:** W: 208 x H: 5 x D: 38 cm.



## Custom-Sized Cushion

**CUSPE:** The cushion can be upholstered in customer-specific fabric.

Please contact the retailer.



## Accessories/Installation

**Connecting Screws:** Set of 10 pieces, including both round-head and flat-head screws.

Connecting screws are available for shelving units in 12 mm and 16 mm thickness.

When ordering, please specify the type.

It is recommended to use connecting screws for System Seating.



# System Seating surfaces

## System Seating Modules

The Montana System Seating modules are made from 12 mm MDF and are available in all of Montana's lacquer colours.

### Lacquered MDF

Montana System Seating is available in all of Montana's lacquer colours.

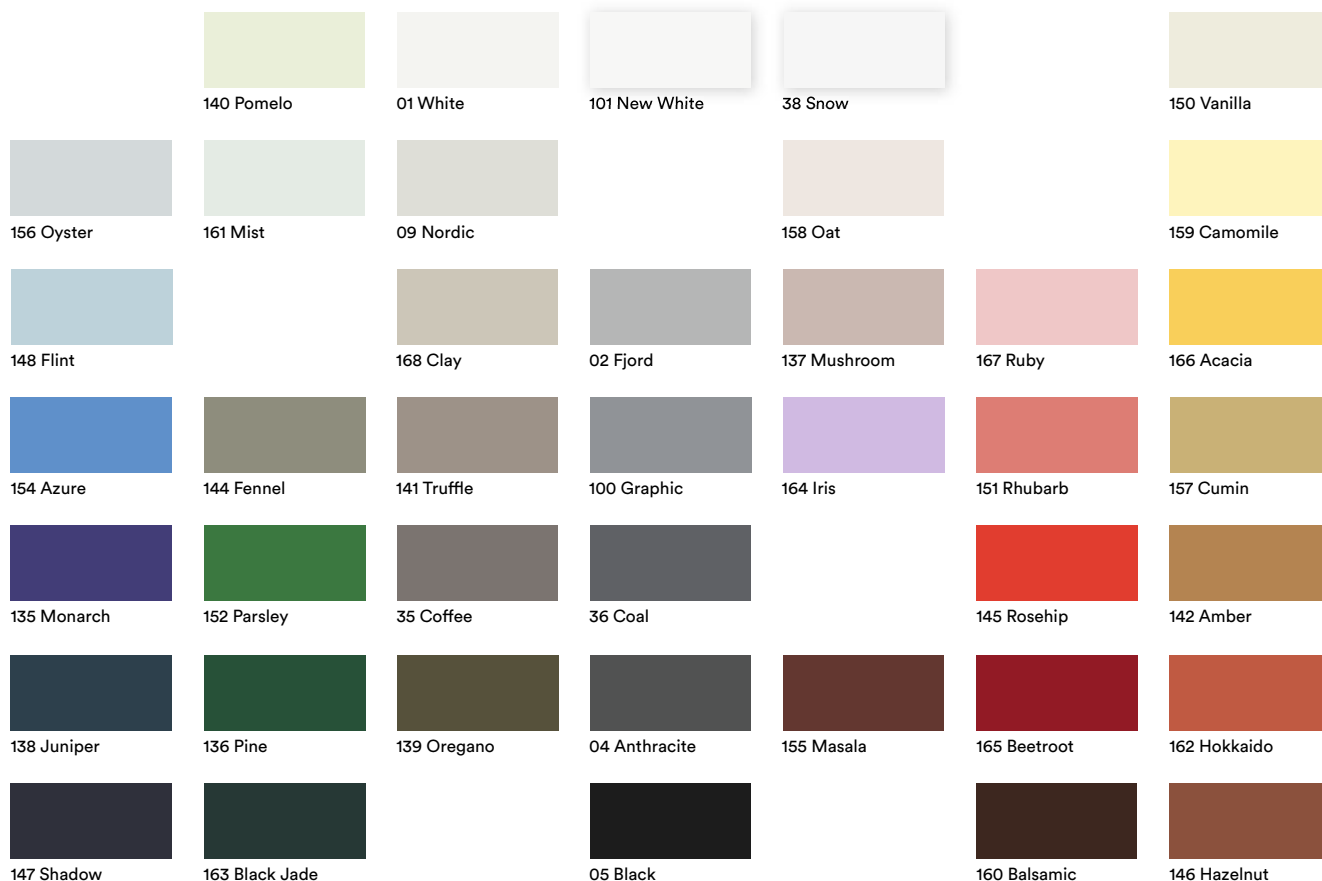

## System Seating Cushions

The cushion is available in a selection of 4 standard textiles. Fabrics outside the standard selection can be purchased at an additional cost.

### Cushions

Recycled polyester

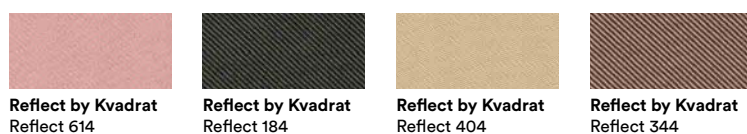

Please note that printed colours may differ from the original colour.



# Montana Hall

12 mm MDF / Design: Peter J. Lassen



## Furniture for the Hallway

Montana Hall is a series of storage solutions specifically designed for the hallway. The series includes storage modules, shoe benches, and a clothes rail, which can be freely combined to create a practical and stylish interior.

### Technical Information

Hall consists of products made from 12 mm MDF, except for the shoe benches, which are made from 30 mm MDF. These products are available in all of Montana's lacquer colours.

# Montana Hall overview

---

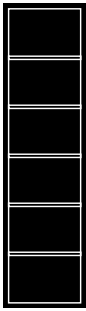

Side-hung Modules

56



Shoe Benches

56



Hall Storage

56

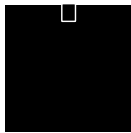

Canvas Storage Boxes

56



Clothes Rail

56



Racks

309

See information about our coat racks under Accessories on page 309 >



Surfaces

57

# Montana Hall

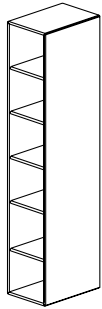

(\*24 x \*4)

## VI24L/R

W 24 x H 138 x D 38 cm

Side-hung modules can be ordered as right- or left-handed. A left-handed module is defined as one where the mounting is installed on the left side of the module when viewed from the front. The mounting is made of aluminium with a 0.5 cm gap between the module and the wall.

Side-hung modules can be supplied with a mirror at an additional cost.

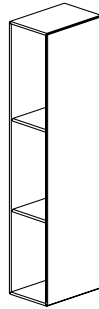

(\*24 x \*4)

## VI25L/R

W 24 x H 138 x D 38 cm

Side-hung modules can be ordered as right- or left-handed. A left-handed module is defined as one where the mounting is installed on the left side of the module when viewed from the front. The mounting is made of aluminium, with a 0.5 cm gap between the module and the wall.

Side-hung modules can be supplied with a mirror at an additional cost.

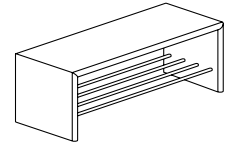

## MONTSK

W 100 x H 45 x D 40 cm

The shoe benches combine seating and shoe storage, with shoe rods in brushed stainless steel, positioned 11 cm from the floor.

**Maximum load:** 100 kg evenly distributed.

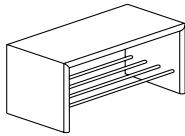

## MON80

W 80 x H 45 x D 40 cm

The shoe benches combine seating and shoe storage, with shoe rods in brushed stainless steel, positioned 11 cm from the floor.

**Maximum load:** 100 kg evenly distributed.

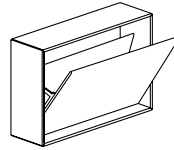

(\*8 x \*12)

## 4229

W 69.6 x H 46.8 x D 20/30 cm.

The lining in the tilt drawer comes in white with a transparent plastic insert that protects against dirty shoe soles. The useful surface in the drawer is W: 64 cm and accommodates 2-3 pairs of shoes at D: 20 cm. At D: 30 cm, it can hold 4-6 pairs of shoes. The internal height of the drawer front is 39.5 cm.

**Maximum load:** 10 kg.

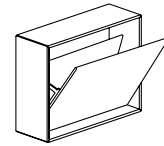

(\*8 x \*8)

## 4240

W 46.8 x H 46.8 x D 20/30 cm

The lining in the tilt drawer comes in white with a transparent plastic insert that protects against dirty shoe soles. The useful surface in the drawer is W: 41.5 cm and accommodates 1-2 pairs of shoes at D: 20 cm. At D: 30 cm, it can hold 3-4 pairs of shoes. The internal height of the drawer front is 39.5 cm.

**Maximum load:** 10 kg.

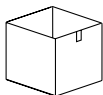

Fits to (\*4 x \*4)

## 7171BO

W 20.5 x H 20 x D 35 cm

The storage box is made from light grey canvas with a 2.5 cm wide strap in black leather.

It fits in the side-hung Hall module with a depth of 38 cm.



## BS1312 / BS1330 / BS1338

Clothes rails in the Hall Edition are available in two versions, both in stainless steel for mounting under modules. One version is adapted for modules with a width of 69.6 cm (\*12), and the other version is for modules with a depth of 30 or 38 cm.

Read more about clothes rails on page 22 >

# Montana Hall surfaces

## Materials

The Montana Hall modules are made from 12 mm MDF.

## Lacquered MDF

Montana Hall is available in all of Montana's lacquer colours.





# Montana Mega

12 mm MDF / Design: Peter J. Lassen



## Wide Shelves and Sideboards

Montana Mega is a module that is wider than the standard modules in the Montana System. The series consists of 9 fixed designs with a width of 115.2 cm (\*20) and heights of 103.8 cm (\*18), 69.6 cm (\*12), and 46.8 cm (\*8), and only a depth of 38 cm. The modules are available exclusively with a plinth height of 3 or 7 cm or with legs, which accentuate their bold and clean design.

### Technical Information

Montana Mega is only available in D: 38 cm, and the fixed configurations cannot have additional components added. To ensure stability, the shelves are screwed into the back panel with through screws, and when choosing legs, the shelving units are fitted with a particularly strong metal support rail under the base.

Montana Mega modules can support up to 40 kg, making them both functional and robust for storage and display.

Coloured handles and brass handles are available at an additional cost.



# Montana Mega pre-designed

Mega in width 115,2 cm (\*20)

Depth 38 cm

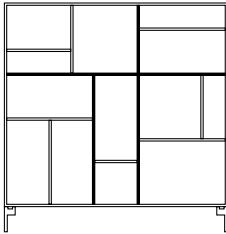

(\*20 x \*18)

201801

115.2 x 103.8 cm

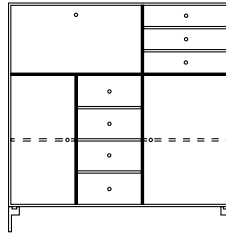

(\*20 x \*18)

201802

115.2 x 103.8 cm

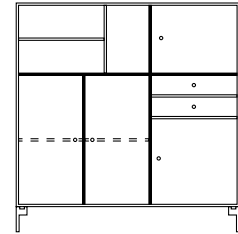

(\*20 x \*18)

201803

115.2 x 103.8 cm

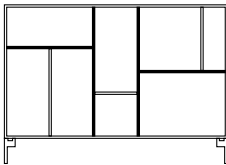

(\*20 x \*12)

201201

115.2 x 69.6 cm

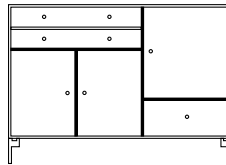

(\*20 x \*12)

201202

115.2 x 69.6 cm

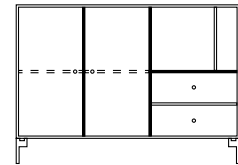

(\*20 x \*12)

201203

115.2 x 69.6 cm

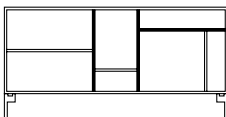

(\*20 x \*8)

200801

115.2 x 46.8 cm

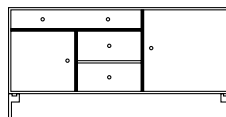

(\*20 x \*8)

200802

115.2 x 46.8 cm

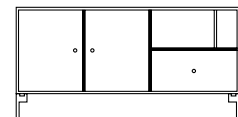

(\*20 x \*8)

200803

115.2 x 46.8 cm



## Signatures ▶



Shelves



Fixed shelves



Hidden, fixed shelves



Doors



Drawers

P indicates that drawers/doors are handle-free with push.

Surfaces

61



# Montana Mega surfaces

## Materials

Montana Mega is made from 12 mm MDF in all of Montana's lacquer colours and comes with plinths in all lacquer colours, as well as legs lacquered in all lacquer colours, matt chrome-plated zinc, and brass.

## Lacquered MDF / Powder-Coated Metal (Legs)

Montana Mega modules and legs are available in all of Montana's lacquer colours.



## Legs

Available in all of Montana's lacquer colours, matt chrome-plated zinc, and brass.



**Matt Chrome-Plated Zinc**  
99 MattChrome



**Brass 195 Brass**



# Montana Mini

8 mm MDF / Design: Peter J. Lassen



## Versatile and Compact Storage

Montana Mini is a series of simple and flexible storage modules designed for easy and functional storage. The series is available in different variants with either doors, drawers, or open shelves, and is offered in ten selected colours. Top panels and plinths can be purchased separately. Additionally, the series includes a range of accessories, including mirrors, a magnetic notice board, and a storage box on castors, all adding further functionality and usage options.

### Technical Information

Montana Mini consists of shelving units made from 8 mm MDF in W: 35 x H: 35 x D: 25 cm, available in various versions: empty module, module with shelves, module with a door, and module with one or more drawers.

The drawer module comes with one, two, or three drawers. The drawers can be fully extended from the module, and the module can also be used without drawers. The drawers cannot be purchased separately.

The shelving units are supplied with wall mounting brackets.

Top panels can be purchased for one or two shelving units, as well as a plinth for a single module. Montana Mini shelving units can support a maximum of 10 kg.

**Quick Ship Delivery:** Dispatch within 6-8 business days.

# Montana Mini overview

---

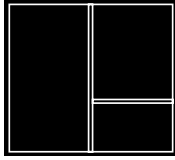

---

Mini Series

64

Components

66

Surfaces

67



# Montana Mini pre-designed

Modules with a width of 35 cm

Depth 25 cm

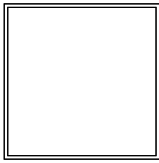

1001

35 x 35 cm

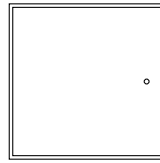

1003

35 x 35 cm

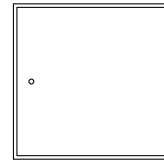

1103

35 x 35 cm

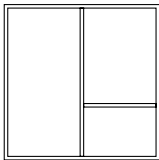

1002

35 x 35 cm

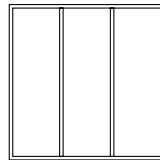

1104

35 x 35 cm

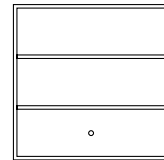

1005

35 x 35 cm

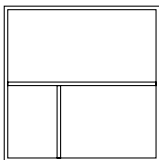

1102

35 x 35 cm

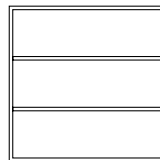

1004

35 x 35 cm

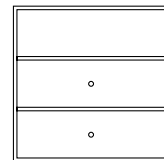

1006

35 x 35 cm

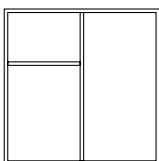

1202

35 x 35 cm

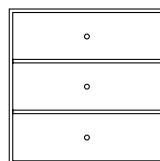

1007

35 x 35 cm

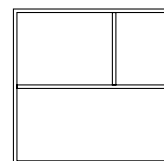

1302

35 x 35 cm

# Montana Mini pre-designed

---

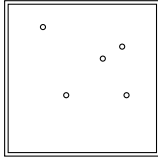

---

**Noticeboard / MBOARD** 35 x 35 cm

---

Noticeboard comes with 5 magnets lacquered in the same colour as the board.

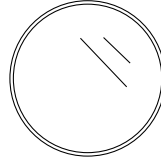

---

**Mirror / MCI** Ø35 cm

---

Mini Mirrors are made from 3 mm silver glass mirror on an 8 mm MDF board with an 8 mm mirror frame.

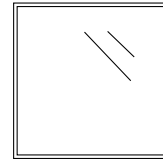

---

**Mirror / MSQ** 35 x 35 cm

---

Mini Mirrors are made from 3 mm silver glass mirror on an 8 mm MDF board with an 8 mm mirror frame.

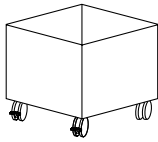

---

**Mini Play box / MP1001** 35 x 35 cm

---

Height of the box including black CR70 castors: 31.8 cm

# Montana Mini components

---



## Top Panel

Top panels made from 8 mm lacquered MDF.

**2004:** W: 35 cm for one Montana Mini module

**2005:** W: 70 cm for two Montana Mini modules

Top panels are supplied with anti-slip pads.



## Plinth

**MPLI:** A plinth is equipped with 4 leveling screws, allowing it to be levelled.

Anti-slip pads are placed in the 4 corners of the plinth and then placed on the module.

# Montana Mini surfaces

---

## Materials

**Montana Mini** modules are made from 8 mm MDF lacquered in all Montana colours.

**Mini Mirrors** are made from 3 mm silver glass mirror on an 8 mm MDF board with an 8 mm mirror frame.

The **Mini Play box** is a module with black CR70 castors.

## Lacquered MDF

Montana Mini, Mini Play box, Noticeboard, mirrors, top panels and plinth.

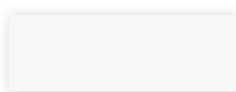

101 New White



04 Anthracite



148 Flint



159 Camomile



09 Nordic



142 Amber



168 Clay



167 Ruby



144 Fennel



45 Rosehip



# Wardrobe

16 mm MDF / Design: Peter J. Lassen



## Wardrobe and Storage Solutions

Montana Wardrobe is a modular wardrobe system designed to adapt to different needs and spaces. The updated Wardrobe assortment introduces a new module width 53.3 cm (\*9) and is available in two depths, 60 cm and 38.8 cm, offering increased flexibility for spatial planning and interior layouts. The modules are available in heights 186.4 cm (\*32+), 150.2 cm (\*26), 116 cm (\*20), 70.4 cm (\*12) and 36.2 cm (\*6) and can be wall-mounted or placed on a plinth. The units can be positioned freely in the room, as all cabinets are designed with a finished back and can function as room dividers. The system supports a wide range of interior configurations with shelves, drawers, clothes rails and accessories, and is designed as a long-lasting solution that can be reconfigured or relocated over time as needs change.

### Technical Information

The Montana Wardrobe is constructed from 16 mm lacquered MDF. For stability, it is recommended that modules mounted on a plinth are connected with screws to prevent twisting. Modules equipped with drawers present an increased risk of tipping; therefore, it is advised that these modules be securely attached to the wall. Modules positioned on a plinth have a maximum load capacity of 40 kg.

The Wardrobe OP9W suspension rail from Montana is reinforced and not suitable for retrofitting. Upon installation, a 12 mm reinforcement strip is doweled into the module's corpus. From the back, the suspension resembles other Montana suspensions, utilizing two black recycled plastic brackets. The suspension on the module is secured through the reinforcement strip, back panel, and plastic brackets. The wall-mounted suspension rail, made of plywood, is supplied with an adjustment bracket allowing for horizontal alignment. Spacer knobs on the back panel facilitate adjustment against the wall. Suspended modules hang 8 mm away from the wall.

Suspended wardrobe modules with heights of 36.2 cm (\*6) and 70.4 cm (\*12) support loads up to 20 kg, while those at 116 cm (\*20), 150.2 cm (\*26), and 186.4 cm (\*32+) can accommodate up to 40 kg. Drawers have a maximum load of 15 kg each; however, the total weight must never exceed the module's specified limit. It is also recommended to interconnect modules for added safety.

For optimal security, installation should preferably be on concrete or brick walls; plaster walls must consist of at least two layers.

# Wardrobe overview

---

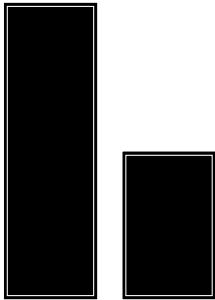

Base Modules

70



Wardrobe Star System and Measurements

71

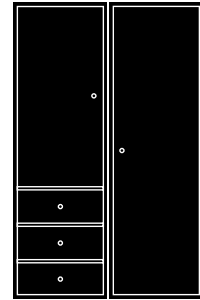

Wardrobe Pre-designed

72

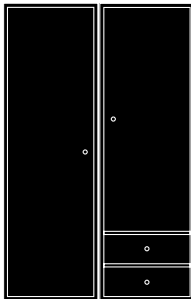

Modules

73 - 74

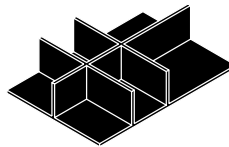

Wardrobe Components

75



Surfaces

79

# Wardrobe base modules

## Base Modules

Wardrobe consists of 5 base modules with a depth of 60 cm. If you wish to design your own personalised wardrobe, the base modules can be enhanced with many practical components. An overview of all internal and external measurements can be found on the next page.

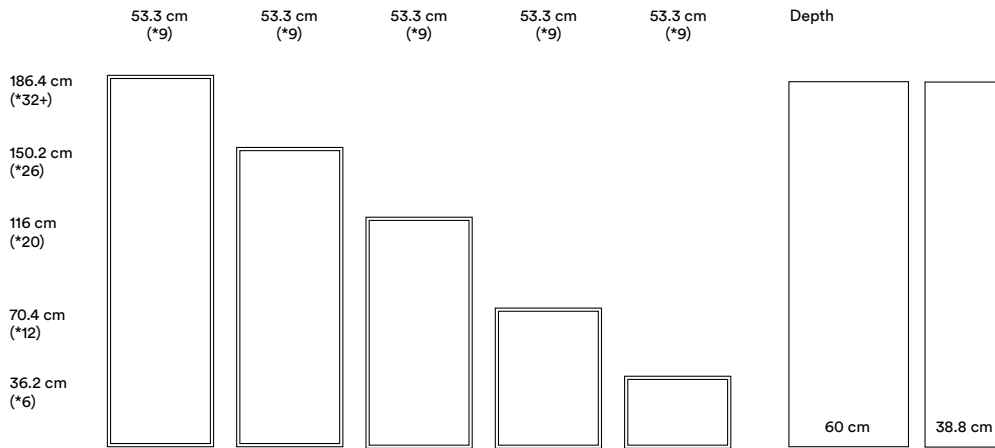
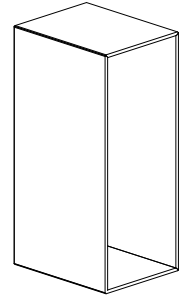

## Position

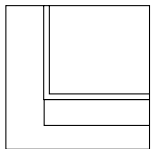

Plinths

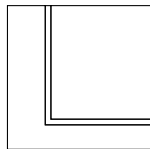

Wall-mounted

# Wardrobe star system and measurements

## ★ Star System and Measurements

With the star system, you can easily find modules and components that match in size.

### Wardrobe units

*Measurements	Internal	External
*1	4.5 cm	7.7 cm
*2	10.2 cm	13.4 cm
*3	15.9 cm	19.1 cm
*4	21.6 cm	24.8 cm
*5	27.3 cm	30.5 cm
*6	33.0 cm	36.2 cm
*7	38.7 cm	41.9 cm
*8	44.4 cm	47.6 cm
*9	50.1 cm	53.3 cm
*10	55.8 cm	59.0 cm
*11	61.5 cm	64.7 cm
*12	67.2 cm	70.4 cm
*13	72.9 cm	76.1 cm
*14	78.6 cm	81.8 cm
*15	84.3 cm	87.5 cm
*16	90.0 cm	93.2 cm
*17	95.7 cm	98.9 cm
*18	101.4 cm	104.6 cm
*19	107.1 cm	110.3 cm
*20	112.8 cm	116.0 cm
*24	135.6 cm	138.8 cm
*26	147.0 cm	150.2 cm
*32+	183.2 cm	186.4 cm

### Internal Measurements

Depth	Internal Measurements in open shelves	Internal Measurements behind door
60 cm	58.2 cm	55.3 cm
38.8 cm	37.3 cm	34.3 cm

### Drawers

Drawer	W x H	Depth 60 cm	Depth 38.8 cm
92	W: 45.9 cm x H: 6.6 cm (5 cm drawer lining)	48.8 cm	31.3 cm
93	W: 45.9 cm x H: 12.3 cm (10.8 cm drawer lining)	48.8 cm	31.3 cm
94	W: 45.9 cm x H: 17.9 cm (16.4 cm drawer lining)	48.8 cm	31.3 cm
96	W: 45.9 cm x H: 29.2 cm (27.7 cm drawer lining)	48.8 cm	31.3 cm



# Wardrobe pre-designed

Examples of Pre-Designed Wardrobe Modules. Position: Wall /Plinth

Depth 38.8/60 cm

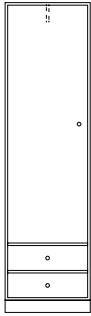

DP13

## ATTIRE I

W 53,3 x H 186,4 x D 38,8 cm

1 x **DP13** including lacquered handles.  
Available with wall mounting or on a plinth height 3 cm and 7 cm. (Above measurements ex. plinth).

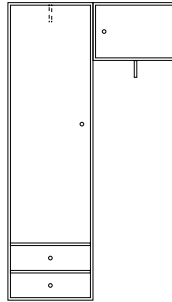

DP13 / XP17

## ATTIRE II

W 106,6 x H 186,4/36,2 x D 38,8 cm

1 x **DP13** (W: 53.3 x H: 186.4 x D: 38.8 cm)  
1 x **XP17** (W: 53.3 x H: 36.2 x D: 38.8 cm),  
including lacquered handles.  
Available with wall mounting or on a plinth in heights 3 cm and 7 cm.

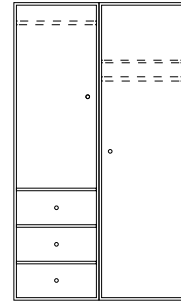

DP15 / DP12

## ATTIRE III

W 106,6 x H 186,4 x D 60 cm

1 x **DP15** (W: 53.3 x H: 186.4 x D: 60 cm)  
1 x **DP12** (W: 53.3 x H: 186.4 x D: 60 cm),  
including lacquered handles.  
Available with wall mounting or on a plinth, height 3 cm and 7 cm.

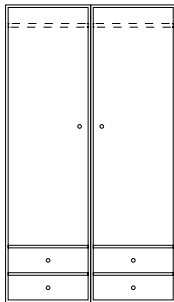

2 x DP13

## ATTIRE IV

W 106,6 x H 186,4 x D 60 cm

2 x **DP13** (W: 53.3 x H: 186.4 x D: 60 cm),  
including lacquered handles.  
Available with wall mounting or on a plinth, height 3 cm and 7 cm.

### Signatures ►



Doors

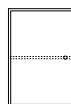

Shelves behind door

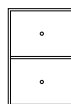

Drawers

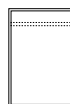

Clothes rail behind door



Clothes rail behind door



Clothes rail in module without door



Clothes rail below module

# Wardrobe overview

Modules in width 53.3 cm

Depth 60 cm

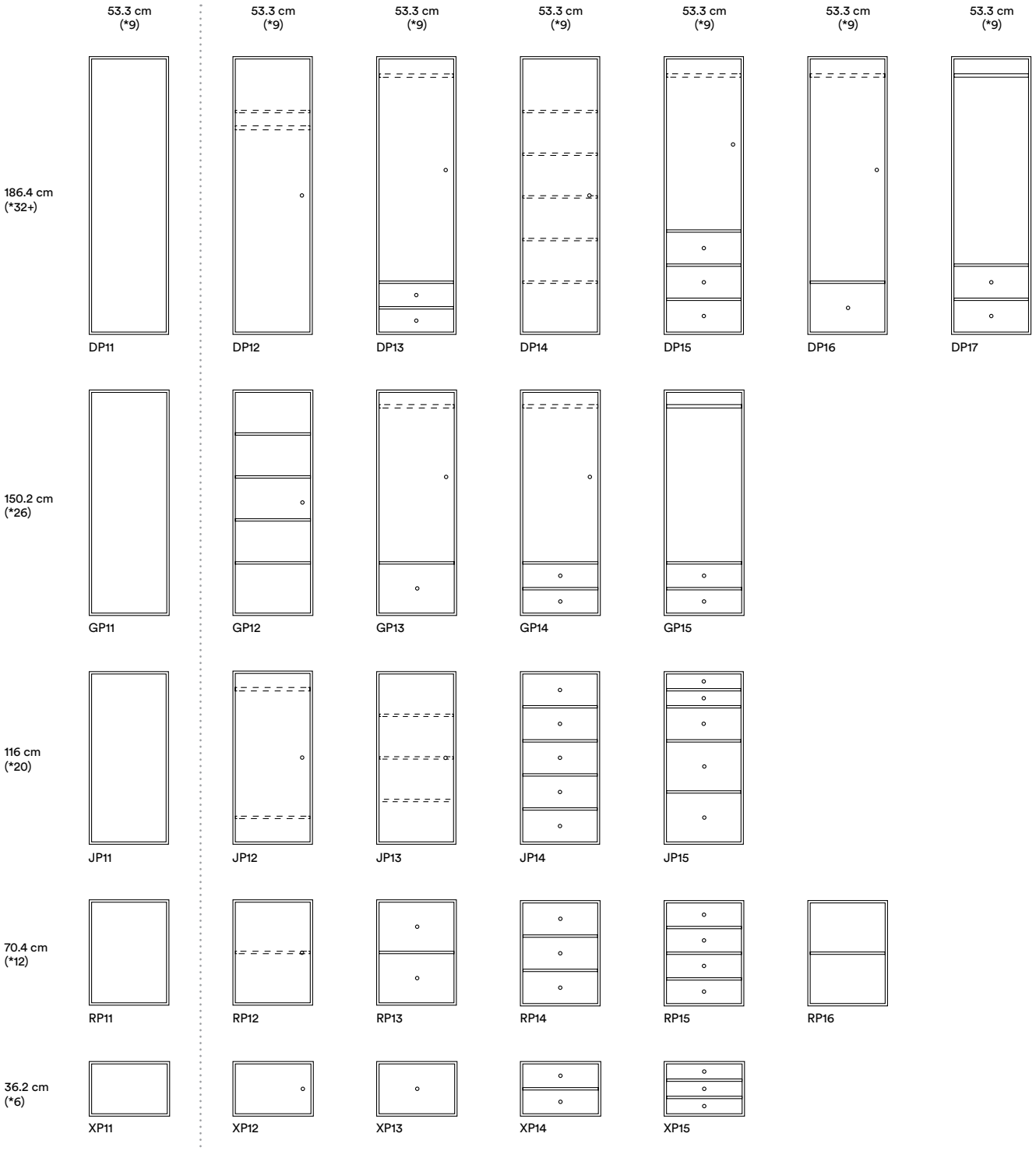

## Signatures ▶

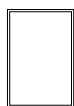

Basic units



Doors



Fixed shelves



Shelves behind doors



Drawers

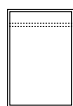

Clothes rail behind door



Clothes rail in module without door

# Wardrobe overview

Modules in width 53.3 cm

Depth 38.8 cm

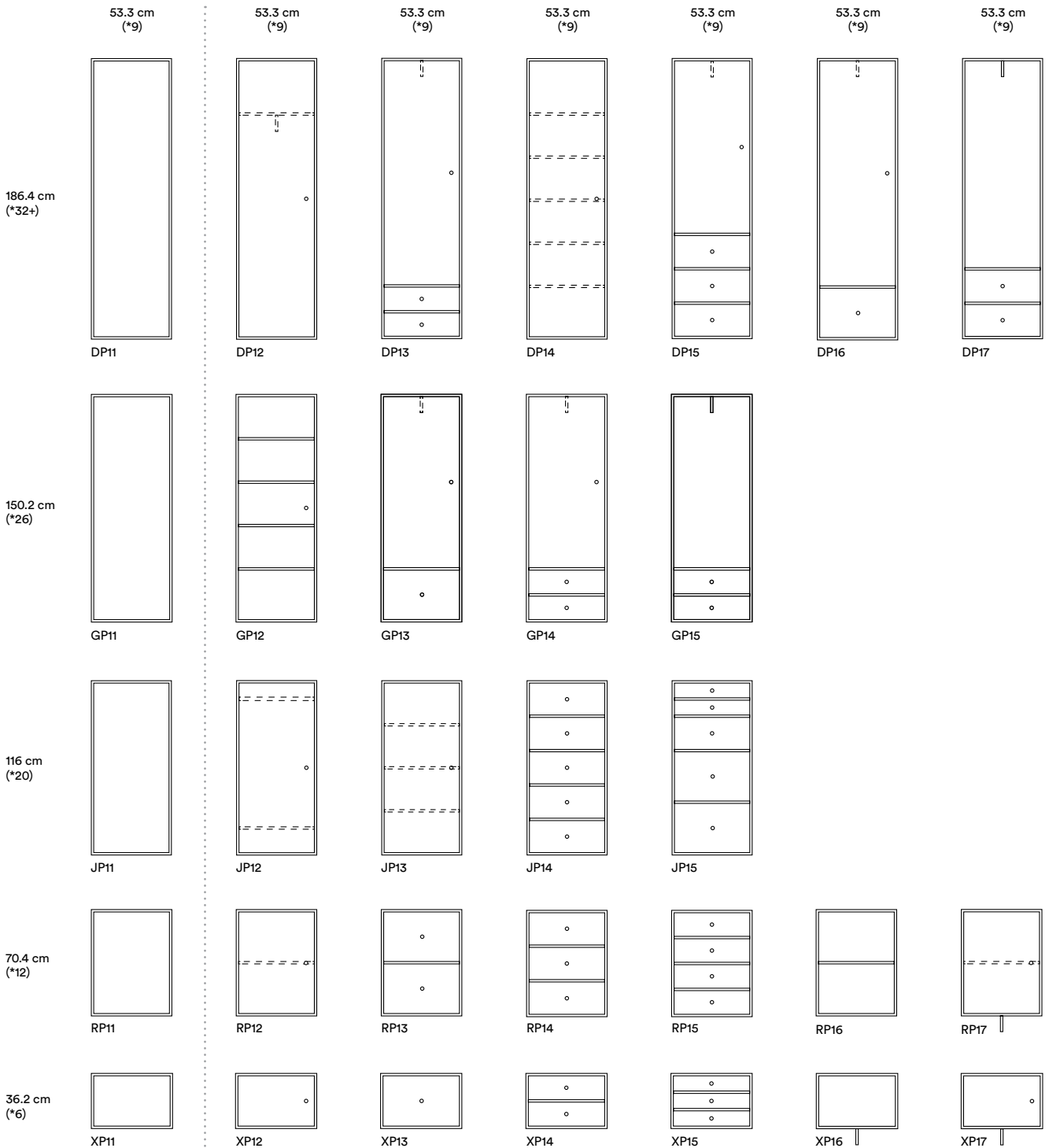

**Signatures** ▶

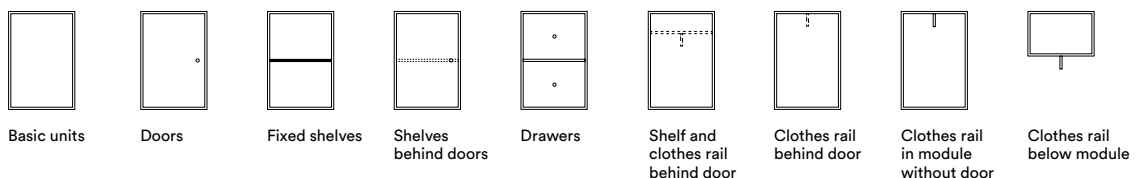



# Wardrobe

EU ECOLABEL CERTIFIED

## Components

A wide range of components makes it possible to assemble your personalised Montana Wardrobe. Start with the base modules and build a wardrobe from the ground up, or add further functionality to a pre-designed module with components such as shelves, doors, or clothes rails.

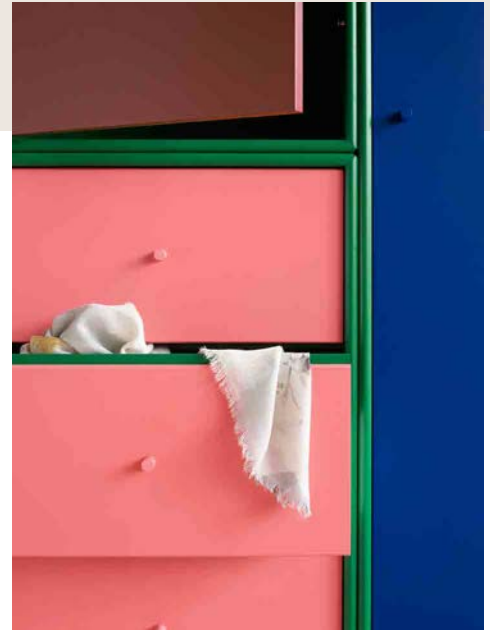

# Wardrobe components



## Doors

Doors measure 53.3 cm (\*9) and are made from 16 mm lacquered MDF. They are always supplied with lacquered handles in the same colour as the front, positioned on the opposite side of the hinge.

Models 932L, 926L, and 920L are extra-tall doors designed specifically for DP modules measuring 186.4 cm (\*32+).

Fronts without pre-drilled holes for handles are also available if you prefer a different handle placement. This option is available at an additional cost — please contact Customer Service for pricing.



## Drawers

Drawers are available in the following heights: 9.9 cm (\*2), 15.6 cm (\*3), 21.3 cm (\*4) and 32.5 cm (\*6).

Drawer fronts are made from 12 mm lacquered MDF with white-pigmented drawer lining for heights \*2, \*3 and \*4. For height \*6, the drawer lining is in white lacquered MDF. The base is a 4 mm white MDF board.

Drawer runners are smooth-running metal extensions with soft-close and 100% extension, and all drawers feature full-height drawer lining.

Handles are lacquered in the same colour as the drawer front.



## Shelf

Shelves in depths of 60 cm and 38.8 cm are made from 12 mm lacquered MDF board. When ordering, please specify whether the shelf is intended for use in an open shelving unit or behind a door.

# Wardrobe components



## Drawer Divider

**WDFILT:** Width 53.3 cm (\*9) in height 9.9 cm (\*2), available in two depths: D 60 cm and D 38.8 cm.

**92 D38:** W 45.8 cm × D 31.2 cm × H 5 cm

**92 D60:** W 45.8 cm × D 53.7 cm × H 5 cm

Material: AQSorb® consists of 100% PET plastic, of which 75% is recycled. Thickness: 10 mm, off-white finish.



## Drawer Divider

**WDFILT:** Width 53.3 cm (\*9) in height 15.6 cm (\*3), available in two depths: D 60 cm and D 38.8 cm.

**93 D38:** W 45.8 cm × D 31.2 cm × H 10.7 cm

**93 D60:** W 45.8 cm × D 53.7 cm × H 10.7 cm

Material: AQSorb® consists of 100% PET plastic, of which 75% is recycled. Thickness: 10 mm, off-white finish



## Wall Mounting Bracket

**OP9W** – reinforced wall bracket, 12 mm thick. The OP9W bracket is horizontally adjustable via a rotating bracket in the mounting rail. It is supplied with spacers and screws for wall adjustment and is suitable for wall mounting wardrobe modules.

Wardrobe modules cannot be retrofitted with a wall bracket.

Read more about our support brackets on [page 24 >](#).



## Door Hinge

**HTW:** 1 piece Wardrobe door hinge. For large wardrobe doors, 3 hinges are used per door.



## Handle – G9

Improved functionality: The G9 handle has a slightly deeper grip, making it easier to open larger doors and drawers. The look remains identical to the current G6, but it's slightly larger (+1 mm in diameter and +1.5 mm in length).

# Wardrobe components

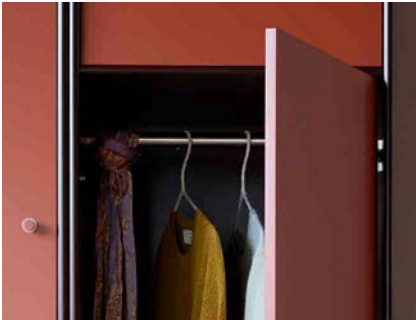

## Clothes Rails, inside Modules

Clothes rail, internal, D 60 cm

Length: 50.1 cm.



## Clothes Rails, inside Modules

For modules in depth 38.8 cm – Ø13 mm in brushed stainless steel, mounted at the top of the module, inside on a 12 mm plate for reinforcement, or externally underneath the module. The clothes rail in depth 38.8 cm is mounted within the module's depth

Length: 29.3 cm.



## Clothes rails, under modules

For modules with a depth of 38.8 cm – Ø13 mm in brushed stainless steel. Mounted at the top of the module, either internally on a 12 mm reinforcement plate or externally underneath the module.

The clothes rail for depth 38.8 cm is mounted within the module's depth.

Length: 29.3 cm.



## Equalising Plate

Equalising plate available in two depths: 38.8 cm and 60 cm, made from 20 mm MDF. The plate is placed in the plinth when combining modules — for example, 36.2 cm (\*6) + 116 cm (\*20) next to 150.2 cm (\*26), or 2 × 36.2 cm (\*6) next to 70.4 cm (\*12).

# Wardrobe surfaces

## Materials

16 mm MDF, lacquered in all of Montana's lacquer colours.  
Plinths are also available in all of Montana's lacquer colours.

## Lacquered MDF

Wardrobe models are available in all of Montana's lacquer colours.





# Montana Selection

12 mm MDF / Design: Peter J. Lassen



## Pre-designed Furniture

Montana Selection is a series of pre-designed furniture for the home – from cabinets and bookshelves to bedside tables. These are functional and creative pieces of furniture with fixed, defined depths. The only decision you need to make is to choose a colour from all of Montana's lacquer colours and select from the different platform types – wall-mounted, plinth, legs, and castors.

### Technical Information

Plinths can be chosen in heights of 3 or 7 cm. Castors for Selection are CR70 castors in black. Legs for Selection are available in selected colours. Handles are lacquered and match the front colour. If you want a customisation of Selection – colour, depth, components, etc., it will be built up from the system.

The Montana Selection series can be ordered with Quick Ship delivery: Dispatch within 6-8 business days in selected Quick Ship colours.

Quick Ship colours are shown on page 87 >.



# Montana Selection pre-designed

Additional Height for Modules with: Legs +12.6 cm. Castors +6.8 cm. Plinth +3 cm. Plinth +7 cm.

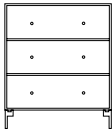

## DRESSERS (\*12 x \*12)

**CARRY** W 69.6 x H 69.6 x D 38 cm

1 x **1128** including lacquered handles. Can be chosen with wall mounting, plinth, or legs.



## DRESSERS

**KEEP** W 69.6 x H 82.2 x D 46/30 cm

1 x **1125** (W: 69.6 cm x H: 69.6 cm) D: 46.8 cm, including lacquered handles.  
1 x **8112** (W: 69.6 cm x H: 12.6 cm) D: 30 cm, including 1 x **62** drawer, including lacquered handles. Can be chosen with wall mounting, plinth, or legs.



## NIGHT TABLES (\*6 x \*4)

**DASH** W 35.4 x H 24 x D 30 cm

1 x **7161** including 1 x **6X** shelf and 1 x **62** drawer with lacquered handles. Can be chosen with wall mounting.



## NIGHT TABLES (\*6 x \*6)

**DRIFT** W 35.4 x H 35.4 x D 30 cm

1 x **6264** including lacquered handles. Can be chosen with wall mounting, plinth, legs, or castors.



## NIGHT TABLES (\*6 x \*6)

**DREAM** W 35.4 x H 35.4 x D 30 cm

1 x **6262** including lacquered handles. Can be chosen with wall mounting, plinth, legs, or castors.



## WARDROBE

**ATTIRE I** W 53.3 x H 186.4 x D 38.8 cm

1 x **DP13** including lacquered handles. Available with wall mounting or on a plinth.

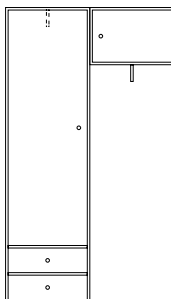

## WARDROBE

**ATTIRE II** W 106.6 x H 186.4/36.2 x D 38.8 cm

1 x **DP13** (W: 53,3 x H: 186,4 cm) D: 38,8 cm.  
1 x **XP17** (W: 53,3 x H: 36,2 cm) D: 38,8 cm, including lacquered handles. Available with wall mounting or on a plinth.

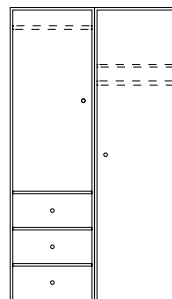

## WARDROBE

**ATTIRE III** W 106.6 x H 186.4 x D 60 cm

1 x **DP15** (W: 53,3 x H: 186,4 cm) D: 60 cm.  
1 x **DP12** (W: 53,3 x H: 186,4 cm) D: 60 cm, including lacquered handles. Available with wall mounting or on a plinth.

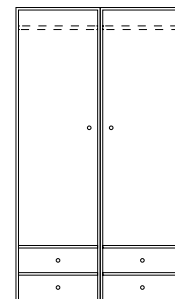

## WARDROBE

**ATTIRE IV** W 106.6 x H 186.4 x D 60 cm

2 x **DP13** (W: 53,3 x H: 186,4 cm) D: 60 cm, including lacquered handles. Available with wall mounting or on a plinth.



# Montana Selection pre-designed

Additional Height for Modules with: Legs +12.6 cm. Castors +6.8 cm. Plinth +3 cm. Plinth +7 cm.



## HOME OFFICE

### WORKSHOP

W 140.7 x H 48.4 x D 46 cm

1 x **7161** (W: 35.4 x H: 24 cm), including 2 x **61** trays and 1 x **62B** tray. 1 x **4161** (W: 35.4 x H: 46.8 cm), including 1 x **68** door with lacquered handles. 1 x lacquered **TOP140** in 16 mm MDF, length 140.7 cm (\*24), \*24: \*6 + \*12 + \*6 (+ 1 mm per module). Anti-slip pads are used between the top panel and the modules. Can only be chosen with wall mounting.

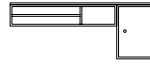

## HOME OFFICE

### BUREAU

W 93.8 x H 36.6 x D 38 cm

1 x **8111** (W: 69.6 cm x H: 12.6), including 1 x **2N** shelf and 2 x **81** trays. 1 x **6171** (W: 24 cm x H: 35.4), including 1 x **46** door with lacquered handles. 1 x lacquered **TOP093** in 12 mm MDF, length 93.8 cm (\*16), \*16: \*12 + \*4 (+ 1 mm per module). Anti-slip pads are used between the top panel and the modules. Can only be chosen with wall mounting. The two modules are connected together.

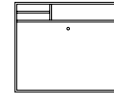

## HOME OFFICE

(\*12 x \*10)

### STUDIO

W 69.6 x H 58.2 x D 30 cm

1 x **2119** including 2 x **41** trays and 1 x **812** bar door, including lacquered handles. Internally with magnet back panel, supplied with 5 magnets lacquered in the module's colour. Available only with wall mounting and must be wall-mounted to prevent tipping.

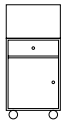

## HOME OFFICE

### RUNNER

W 35.4 x H 66.8 x D 38 cm

1 x **LT3861** (W: 35.4 x H: 20 cm). 1 x **4161** (W: 35.4 x H: 46.8 cm), including 1 x **6X** shelf, 1 x **62** drawer with lacquered handles, and 1 x **66** door with lacquered handles. Can only be chosen with castors.

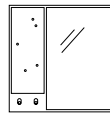

## MIRROR

(\*12 x \*12)

### MEMO

W 69.6 cm x H 69.6 cm x D 3.2 cm

Mirror with magnetic memo board including 5 lacquered magnets and two coat hooks.

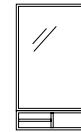

## MIRROR

### GLANCE

W 46.8 x H 82.2 x D 1.6/20 cm

1 x **SP1208** (W: 46.8 cm H: 69.6 cm) 1 x **7641** (W:46.8 x H:12.6 cm), including 1 x **2N** shelf and 2 x **41** trays. Mirror with shelving module with two removable trays.

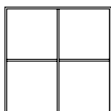

## DISPLAY SHELVES

(\*12 x \*12)

### SHOW

W 69.6 x H 69.6 x D 30 cm

1 x **1112**. Can be chosen with wall mounting, plinth, or legs.

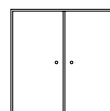

## DISPLAY SHELVES

(\*12 x \*12)

### COVER

W 69.6 x H 69.6 x D 30 cm

1 x **1118** including lacquered handles. Can be chosen with wall mounting, plinth, or legs.

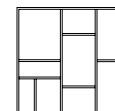

## DISPLAY SHELVES

(\*12 x \*12)

### COMPILE

W 69.6 x H 69.6 x D 30 cm

1 x **1613**. Can be chosen with wall mounting, plinth, or legs.



# Montana Selection pre-designed

Additional Height for Modules with: Legs +12.6 cm. Castors +6.8 cm. Plinth +3 cm. Plinth +7 cm.

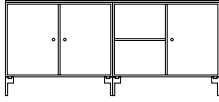

## SIDEBOARDS

### SAVE

W 139.2 x H 48 x D 38 cm

1 x **4120** (W: 69.6 x H: 46.8 cm (\*12 x \*8)) with 2 x **6X** shelves, including lacquered handles. 1 x **4112** (W: 69.6 x H: 46.8 cm (\*12 x \*8)) with 2 x **6X** shelves and 1 x **68** door, including lacquered handles. 1 x **TOP139** top panel, W: 139.4 cm. Can be chosen with wall mounting, plinth, or legs.

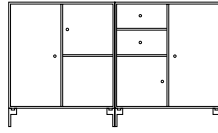

## SIDEBOARDS

### COUPLE

W 139.2 x H 69.6 x D 38 cm

1 x **1112** (W: 69.6 x H: 69.6 cm) including 1 x **612** door and 1 x **66** door, including lacquered handles. 1 x **1112** (W: 69.6 x H: 69.6 cm) including 1 x **612** door, 1 x **66** door, and 2 x **63** drawers, including lacquered handles. Can be chosen with wall mounting, plinth, or legs.

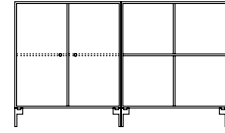

## SIDEBOARDS

### PAIR

W 139.2 x H 69.6 x D 38 cm

1 x **1118** (W: 69.6 x H: 69.6 cm) including lacquered handles. 1 x **1112** (W: 69.6 x H: 69.6 cm). Can be chosen with wall mounting, plinth, or legs.

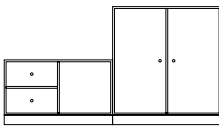

## BENCHES

### REST I

W 139.2 x H 42.4/ 76.6 x D 38 cm

1 x **1118** (W: 69.6 x H: 69.6 cm) including lacquered handles. 1 x **6324** (W: 69.6 x H: 35.4 cm) including lacquered handles. Can only be chosen with a plinth, H: 7 cm.



## BENCHES

### REST II

W 139.2 x H 42.4 x D 38 cm

2 x **6226** (W: 69.6 x H: 35.4 cm) including lacquered handles. Can only be chosen with a plinth, H: 7 cm.



## BENCHES

### REST III

W 208.8 x H 42.4 x D 38 cm

1 x **6112** (W: 69.6 x H: 35.4 cm). 1 x **6126** (W: 69.6 x H: 35.4 cm) including lacquered handles. 1 x **6226** (W: 69.6 x H: 35.4 cm) including lacquered handles. Can only be chosen with a plinth, H: 7 cm.

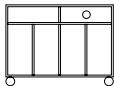

## VINYL STORAGE

(\*12 x \*8)

### SPIN I

W 69.6 x H 69.6 x D 46 cm

1 x **T4215** (W: 69.6 x H: 69.6 cm). Can be chosen with legs or castors.

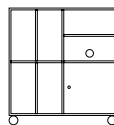

## VINYL STORAGE

(\*12 x \*12)

### SPIN II

W 69.6 x H 69.6 x D 46 cm

1 x **T1429** (W: 69.6 x H: 69.6 cm) including lacquered handles. Can be chosen with wall mounting, legs, or castors.

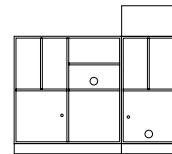

## VINYL STORAGE

### SPIN III

W 105 x H 89.6 x D 38 cm

1 x **T1528** (W: 69.6 x H: 69.6 cm) including lacquered handles. 1 x **LT3861** (W: 35.4 x H: 20 cm). 1 x **T1164** (W: 35.4 x H: 69.6 cm) including lacquered handles. Can be chosen with wall mounting or plinth.



# Montana Selection pre-designed

Additional Height for Modules with: Legs +12.6 cm. Castors +6.8 cm. Plinth +3 cm. Plinth +7 cm.

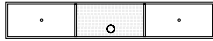

## TV SOUND

### OCTAVE V

W 138 x H 24 x D 30 cm

1 x **VI14** (W: 138 x H: 24 cm) including lacquered handles. Can be chosen with wall mounting or legs.

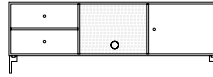

## TV SOUND

### OCTAVE VI

W 138 x H 35.4 x D 38 cm

1 x **SI16** (W: 138 x H: 35.4 cm) including lacquered handles. Can be chosen with wall mounting, plinth, or legs.



## TV SOUND

### OCTAVE VII

W 183.6 x H 24 x D 30 cm

1 x **VE13** (W: 183.6 x H: 24 cm) including lacquered handles. Can be chosen with wall mounting or legs.

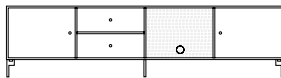

## TV SOUND

### OCTAVE VIII

W 183.6 x H 35.4 x D 38 cm

1 x **SE13** (W: 183.6 x H: 35.4 cm) including lacquered handles. Can be chosen with wall mounting, plinth, or legs.

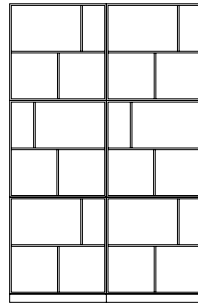

## BOOKSHELVES

### READ

W 139.2 x H 208.8 x D 30 cm

6 x **1212** (W: 69.6 cm x H: 69.6) and 6 x **6X** shelves. Can be chosen with wall mounting or plinth. When selecting READ with wall mounting, all shelves/dividers will be fixed. The top module is fitted with wall mounting when selecting a plinth.

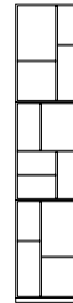

## BOOKSHELVES

### LOOM

W 46.8 x H 208.8 x D 30 cm

2 x **1141** (W: 46.8 cm x H: 69.6) including 1 x **12X** shelf, 1 x **5X** shelf, and 1 x **3X** shelf. 1 x **1141** (W: 46.8 cm x H: 69.6) including 1 x **8X** shelf, 2 x **6X** shelves, and 1 x **5X** shelf. Can be chosen with wall mounting or plinth. The top module is fitted with wall mounting when selecting a plinth.



## HALLWAY

(\*12 x \*4)

### COAT

W 69.6 x H 32.9 x D 30 cm

1 x **7112** (W: 69.6 x H: 24 cm) depth 30 cm, including **BS1312** clothes rail mounted 24.5 cm from the back edge. Can only be chosen with wall mounting. The height of the clothes rails is: 8.9 cm.



## HALLWAY

(\*12 x \*8)

### HIDE

W 69.6 x H 46.8 x D 20 cm

1 x **4229** (W: 69.6 x H: 46.8 cm), depth 20 cm. Can only be chosen with wall mounting.



## HALLWAY

(\*6 x \*6)

### UNLOCK

W 35.4 x H 35.4 x D 20 cm

1 x **SS1214** (W: 35.4 x H: 35.4 cm), depth 20 cm with **6X** shelf, including lacquered handles. 5 x lacquered **G7** handles on the back panel for hanging keys. The key on the front is lacquered in the same colour as the door. Can only be chosen with wall mounting.



# Montana Selection pre-designed

Additional Height for Modules with: Legs +12.6 cm. Castors +6.8 cm. Plinth +3 cm. Plinth +7 cm.



MAKE-UP VANITIES (\*12 x \*2)

**MAKEUP** W 69.6 x H 12.6 x D 30 cm

1 x **8113** including lacquered handles. Can only be chosen with wall mounting. The wall mounting bracket is made of steel.



MAKE-UP VANITIES (\*6 x \*6)

**PERFUME** W 35.4 x H 35.4 x D 20 cm

1 x **6163G** in MDF without pilot holes, with clear glass door, including lacquered handles, shelf in clear glass. Includes double back panel and mirrored back panel in mirror glass. Can only be chosen with wall mounting.



MAKE-UP VANITIES

**PREPPY** W 46.8 x H 79.5 cm x D 30 cm

1 x **82BU** tray in water-resistant MDF without pilot holes (W: 46.8 x H: 9,9 cm). 1 x **PO1216** (W: 46.8 x H: 69.6 cm) storage module in MDF without pilot holes with **CR70** castors. Can only be chosen with castors.



MAKE-UP VANITIES (\*6 x \*8)

**RIPPLE** W 35.4 x H 46.8 x D 20 cm

1 x **OS1225G** in water-resistant MDF without pilot holes, with glass door in ribbed glass, including lacquered handles, and internal glass shelf in regular glass. Can only be chosen with wall mounting.

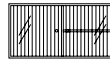

VITRINE (\*6 x \*12)

**RIPPLE CABINET I** W 35.4 x H 35.4 x D 20 cm

1 x **6321R** (W: 69.6 x H: 35.4 cm) including lacquered handles. Can only be chosen with wall mounting. Internal shelves in MDF are supplied on glass shelf supports.

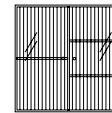

VITRINE (\*12 x \*12)

**RIPPLE CABINET II** W 69.6 x H 69.6 x D 30 cm

1 x **1328R** (W: 69.6 x H: 69.6 cm) including lacquered handles. Can be chosen with wall mounting, plinth, or legs. Internal shelves in MDF are supplied on glass shelf supports.

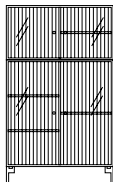

VITRINE

**RIPPLE CABINET III** W 69.6 x H 105 x D 38 cm

1 x **1428R** (W: 69.6 x H: 69.6 cm) including lacquered handles.  
1 x **6321R** (W: 69.6 x H: 35.4 cm) including lacquered handles. Can be chosen with wall mounting, plinth, or legs. Internal shelves in MDF are supplied on glass shelf supports.

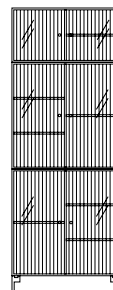

VITRINE

**RIPPLE CABINET IV** W 69.6 x H 174.6 x D 38 cm

1 x **1328R** (W: 69.6 x H: 69.6 cm) including lacquered handles.  
1 x **1428R** (W: 69.6 x H: 69.6 cm) including lacquered handles.  
1 x **6321R** (W: 69.6 x H: 35.4 cm) including lacquered handles.  
Can be chosen with wall mounting, plinth, or legs. The top module is fitted with wall mounting when selecting a plinth or legs. Internal shelves in MDF are supplied on glass shelf supports.

# Montana Selection surfaces / legs / castors

## Materials

Montana Selection is made from 12 mm MDF lacquered in all of Montana's lacquer colours. Handles are always lacquered and match the module's colour. Please note that legs are only available in 8 selected colours in Selection. Castors in black/black. See our Quick Ship colours on the next page. Lacquered MDF Montana Selection is available in all of Montana's lacquer colours.

## Lacquered MDF

Montana Selection is available in all of Montana's lacquer colours.



## Legs

When you choose our Selection furniture, legs are only available in matt chrome-plated zinc, brass, or powder-coated selected Montana colours.

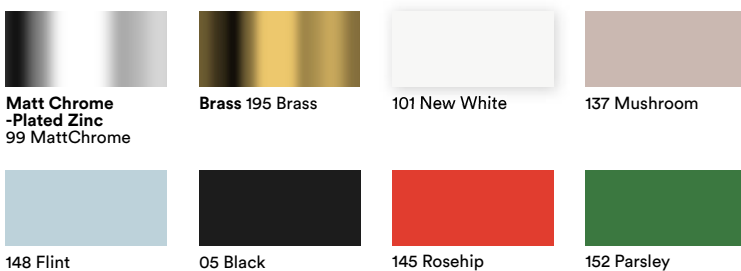

## Castors

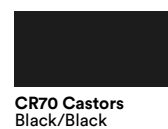

# Quick Ship colours

---

## Quickship Colours

The Montana Selection series can be ordered with Quick Ship delivery: Dispatch within 6-8 business days in selected Quick Ship colours.

### Lacquered MDF

Montana Selection Quick Ship Colours

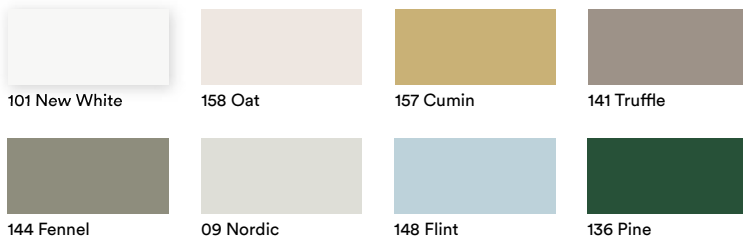

### Legs

When you choose our Selection furniture, legs are only available in matt chrome-plated zinc, brass, or powder-coated selected Montana colours.

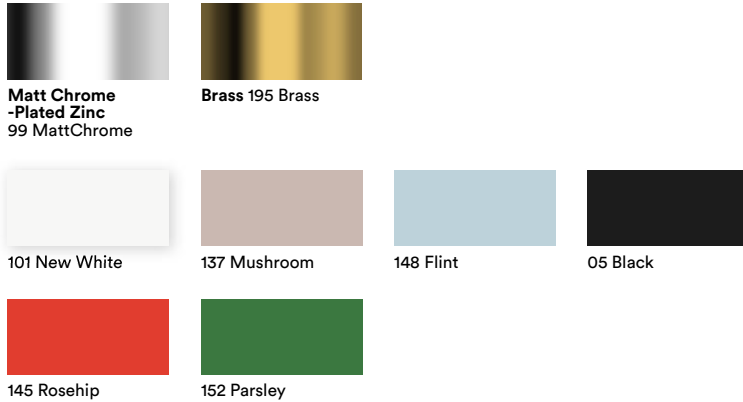

### Castors

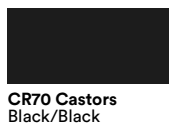



# Montana Free

16 mm MDF / Design: Jakob Wagner



## Freestanding Shelving System

Montana Free is a freestanding shelving system consisting of 16 mm shelves in lacquered MDF with a depth of 38 cm and a supporting structure made of lacquered metal frames and feet.

The shelving unit is available in pre-configured setups or can be freely assembled within the system's maximum height and width, allowing you to create a solution that fits different needs and spaces.

### Technical Information

The shelves are lacquered with a textured lacquer, which ensures a durable and matte surface. The textured lacquer is a paint added with structural beads made of PE plastic.

The frames and feet are lacquered with powder coating or chrome-plated.

Flexible fabric panels, which easily click into place between the frames, can be purchased separately. The fabric panels are moulded from plastic and upholstered with Reflect or Mads Nørgaard Stripes from Kvadrat.

Drawers can be mounted under the shelves, and book supports can be placed between the frames.

Montana Free is delivered flat-packed. Safety brackets EQ Free are included with all setups where required. We recommend that these brackets are mounted under the second-highest shelf. Montana Free is delivered flat-packed.

# Montana Free overview

---

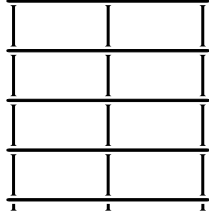

Pre-designed

90 - 91

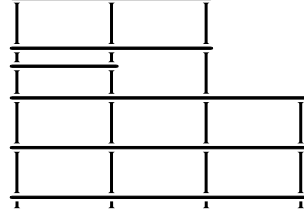

Design your Own

92



Load Capacity Overview

93

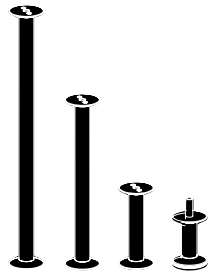

Components

94



Surfaces

97



# Montana Free pre-designed



111010

W 203,4 x H 41,7 cm

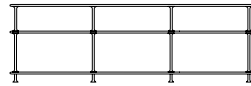

111222

W 203,4 x H 64,4 cm

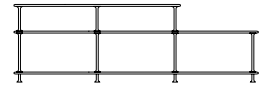

111220

W 203,4 x H 64,4/41,7 cm

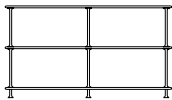

220000

W 138,4 x H 75,8 cm

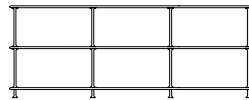

222000

W 203,4 x H 75,8 cm

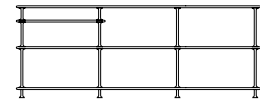

222100

W 203,4 x H 75,8 cm

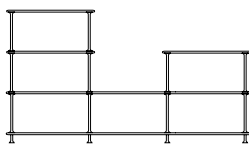

312000

W 203,4 x H 109,9 / 41,7 / 75,8 cm

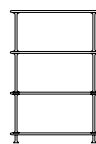

300000

W 73,4 x H 109,9 cm

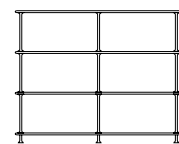

330000

W 138,4 x H 109,9 cm

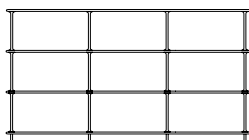

333000

W 203,4 x H 109,9 cm

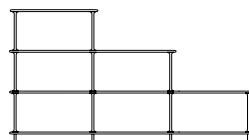

321000

W 203,4 x H 109,9 / 75,8 / 41,7 cm

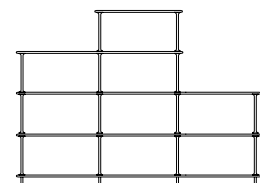

342000

W 203,4 x H 109,9 / 144 / 75,8 cm

Delivered with 1 EQFREE safety bracket.  
The setup should be placed against the wall.  
The safety bracket must be used!

# Montana Free pre-designed

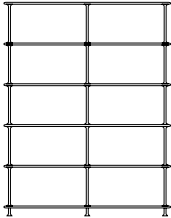

**550000**

W 138,4 x H 178,1 cm

Delivered with 1 EQFREE safety bracket.  
The setup should be placed against the wall.  
The safety bracket must be used!

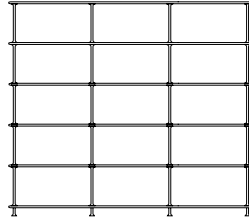

**555000**

W 203,4 x H 178,1 cm

Delivered with 2 EQFREE safety bracket.  
The setup should be placed against the wall.  
The safety bracket must be used!

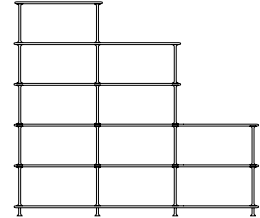

**542000**

W 203,4 x H 178,1 / 144 / 75,8 cm

Delivered with 2 EQFREE safety bracket.  
The setup should be placed against the wall.  
The safety bracket must be used!

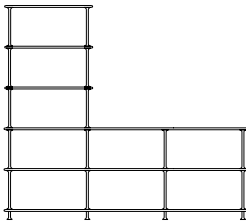

**522000**

W 203,4 x H 178,1 / 75,8 cm

Delivered with 1 EQFREE safety bracket.  
The setup should be placed against the wall.  
The safety bracket must be used!

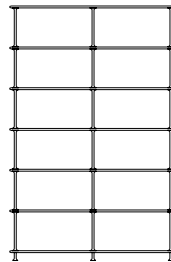

**660000**

W 138,4 x H 212,2 cm

Delivered with 2 EQFREE safety bracket.  
The setup should be placed against the wall.  
The safety bracket must be used!

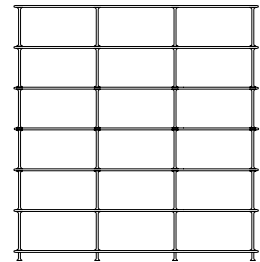

**666000**

W 203,4 x H 212,2 cm

Delivered with 2 EQFREE safety bracket.  
The setup should be placed against the wall.  
The safety bracket must be used!



# Montana Free design your own

## Design your Own

Design your own Montana Free setup by placing components within the grid you see on this page. You can build a maximum height of 212.2 cm (6 levels) and a maximum width of 203.4 cm (3 sections).

Maximum dimensions for setup 666000

W: 203.4 cm

H: 212.2 cm

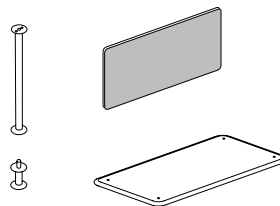
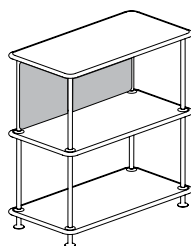
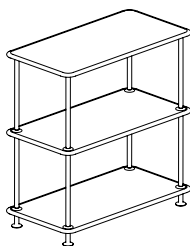
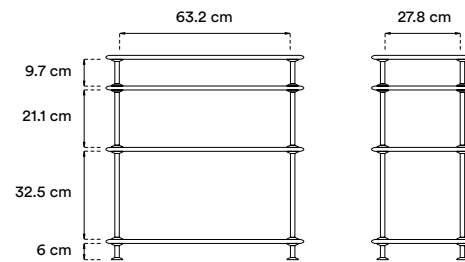
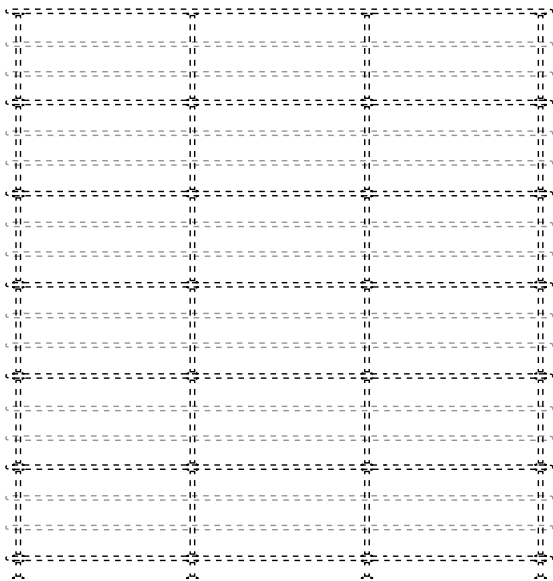



# Montana Free load capacity overview

---

Load capacity shelves
Shelf width 73.4 cm, maximum load 15 kg.
Shelf width 138.4 cm, maximum load 30 kg.
Shelf width 203.4 cm, maximum load 45 kg.

Load capacity width of configurations
Setups with a width of 73.4 cm, maximum load 40 kg.
Setups with a width of 138.4 cm, maximum load 80 kg.
Setups with a width of 203.4 cm, maximum load 120 kg.
The load must be evenly distributed across the entire setup.

Safety brackets
The shelving unit must be placed on a stable and level surface.
The EQFREE safety bracket must be used for the following shelving units:
Setups with a width of 73.4 cm and a height of 41.7 cm (2 shelves).
Setups with a width of 138.4 cm and a height of 69.6 cm (3 shelves).
Setups with a width of 203.1 cm and a height of 138 cm (5 shelves).
Setups with a height of 212.2 cm are recommended to be mounted with 2 × EQFREE.

# Montana Free

EU ECOLABEL CERTIFIED

## Components

Montana Free includes a range of modular components that add functionality and variation to the shelving system. Textile panels adjust transparency and visual expression, while book supports and drawers introduce practical organisation and closed storage within the open structure. The components allow the system to be easily customised and adapted to different uses and interiors.



# Montana Free components



## Fabric Panels

**PAN1:** W: 63.5 cm x H: 32.4 cm.

Upholstered with Reflect or MN Stripes from Kvadrat.



## Legs and Columns

The columns are available in heights that fit Free shelving units, both with and without inserted shelves.

**COL4L:** Set of 4 columns for internal height: 32.5 cm.

**COL4M:** Set of 4 columns, height: 21.1 cm. Used for inserted shelves.

**COL4S:** Set of 4 columns, height: 9.8 cm. Used for inserted shelves.

**COL6L:** Set of 6 columns, height: 32.5 cm.

**LEG4:** Set of 4 legs.

**LEG6:** Set of 6 legs.

The legs are 6 cm in height and can be adjusted up to 2 cm.



## Shelves

Shelves in 16 mm MDF for Montana Free are available in widths of 203.4 cm, 138.4 cm, and 73.4 cm, with a fixed depth of 38 cm. Shelves are made with 2, 4, 6, or 8 holes for columns.

**MF38:** W: 203.4 cm with 8 holes

**MF34:** W: 203.4 cm with 4 holes

**MF24:** W: 138.4 cm with 4 holes

**MF36:** W: 203.4 cm with 6 holes

**MF26:** W: 138.4 cm with 6 holes

**MF22:** W: 138.4 cm with 2 holes

**MF14:** W: 73.4 cm with 4 holes

**MF12:** W: 73.4 cm with 2 holes



## Top Shelves

Top shelves in 16 mm MDF for Montana Free are available in widths of 203.4 cm, 138.4 cm, and 73.4 cm, with a fixed depth of 38 cm, lacquered in Montana Free colours.

Top shelves have no holes, and the underside is equipped with recessed magnets that click onto the columns.

**MF30:** W: 203.4 cm

**MF20:** W: 138.4 cm

**MF10:** W: 73.4 cm



## Drawer

**EQFREE:** The Montana Free drawer is mounted in a cabinet and placed under a shelf.

The cabinet with the drawer measures:  
W: 60 cm x H: 9.8 cm x D: 31.3 cm.

The internal dimensions of the drawer are:  
W: 54 cm x H: 5.3 cm x D: 26 cm.

The drawer is available in all Montana Free colours.



## Book Support

**BOOK1:** Set of 2 pieces. Made of extruded aluminium, powder-coated in Montana Free colours or polished aluminium to match the chrome columns.

The book support is tilted down between two columns and grips the radius of the frames, held in place with plastic ends.

# Montana Free components

---



## Safety Bracket

A safety bracket that fastens the shelving unit to the wall.

The safety bracket is included with all setups in the following sizes:

- **1-section:** Width 73.4 cm, height 41.7 cm (two shelves)
- **2-sections:** Width 138.4 cm, height 69.6 cm (three shelves)
- **3-sections:** Width 203.1 cm, height 138 cm (five shelves)
- **3-sections:** Width 203.1 cm, height 212.2 cm requires 2 × EQFREE.

The bracket is drilled into the wall, and a wire is tightened around a column at the top of the shelving unit. EQFREE is grey.

# Montana Free surfaces

## Materials

Montana Free shelves are made from 16 mm MDF lacquered in textured lacquer. Textured lacquer is paint mixed with structural beads, small beads made of PE plastic, which make the surface more resistant while maintaining the same strength as Montana lacquer without texture.

## Columns and Feet

Columns and feet are powder-coated or chrome-plated.

## Panels

Fabric panels are moulded from plastic and upholstered with Reflect or Mads Nørgaard Stribes from Kvadrat. Reflect is available in 6 different colours, and Mads Nørgaard Stribes is available in 2 colours.

### Shelves Textured Lacquer

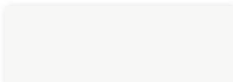

Textured Lacquer  
214 New White



Textured Lacquer  
209 Fjord



Textured Lacquer  
207 Black



Textured Lacquer  
231 Masala



Textured Lacquer 225  
Fennel



Textured Lacquer  
232 Parsley



Textured Lacquer  
167 Ruby



Textured Lacquer  
233 Acacia

### Column Powder-Coated

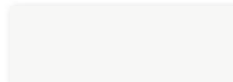

Powder Coat  
101 New White



Powder Coat  
02 Fjord



Powder Coat  
05 Black



Powder Coat  
155 Masala



Powder Coat  
144 Fennel



Powder Coat  
152 Parsley



Powder Coat  
167 Ruby



Powder Coat  
166 Acacia

### Column Chrome



Chrome Chrome 44C

### Fabric Panels Reflect by Kvadrat



Reflect 184



Reflect 204



Reflect 344



Reflect 404

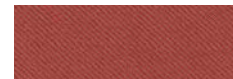

Reflect 564



Reflect 614

### Fabric Panels Mads Nørgaard Stribes



MN Stribes MN1123



MN Stribes MN1629



# Skyline

19 mm MDF / Design: Peter J. Lassen



## Floating Shelves and Tables

Skyline consists of lightweight shelves and tables that float on the wall in a discreet aluminium rail. Skyline is available in various lengths and depths and offers a light and minimalist table or shelf solution.

### Technical Information

Skyline shelves and tables come with a discreet wall rail made of anodised aluminium. Shelves and tables are available in many sizes and finishes. The rail is available in the colours Snow and Black. The rail occupies 2.6 cm of the shelf's usable depth.



## Skyline Shelves

Skyline shelves are available in many sizes and three depths. The discreet wall rail is made of anodised aluminium. Loose wall rails for the Skyline shelf are supplied separately, both in standard and custom lengths. Height: 71 mm. Maximum length: 300 cm. Available in the colours Snow and Black. The rail occupies 2.6 cm of the shelf's usable depth.

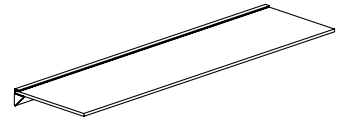

	139.2 cm (*24)	105 cm (*18)	93.6 cm (*16)	69.6 cm (*12)	46.8 cm (*8)
38 cm					
30 cm					
20 cm					
	S139	S105	S93	S69	S46

## Skyline Tables

The wall rail is made of anodised aluminium and is constructed at the top with a cover rail designed for cable management. Provided correct installation and wall conditions, all Skyline tables can support up to 75 kg. The rail occupies 2.6 cm of the table's usable depth.

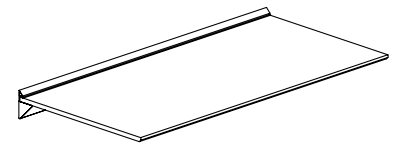

	139.2 cm (*24)	105 cm (*18)	93.6 cm (*16)	69.6 cm (*12)
60 cm				
	BL139	BL105	BL93	BL69

# Skyline Shelves surfaces

## Materials

Skyline shelves are made from 16 mm MDF, available in all of Montana's lacquer colours or as 12 mm shelves in clear glass. Skyline shelves in clear glass are also available in iron-free glass, lacquered in all of Montana's lacquer colours. The discreet wall rail is made of anodised aluminium. The wall rail can, for an additional cost, be supplied powder-coated in the colours 38 Snow and 05 Black.

## Lacquered MDF

Skyline is available in all of Montana's lacquer colours.



## Glass shelf

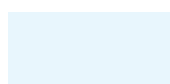

Clear glass

## Rail



43 Aluminium

## Rail Powder-Coated

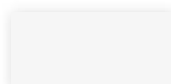

38 Snow



05 Black

# Skyline Table surfaces

---

## Materials

Skyline tables are made from 19 mm MDF with a laminate surface available in 7 different Montana colours. The wall rail can, for an additional cost, be supplied powder-coated in the colours 38 Snow and 05 Black.

### Laminate



Laminate 38L Snow Silk

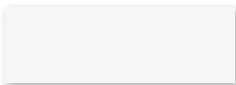

Laminate 38L Snow



Laminate 09L Nordic



Laminate 02L Fjord



Laminate 04L Anthracite



Laminate 157L Cumin



Laminate F3050L Cygnet



Laminate F8240L Liquid glass

### Rail Aluminium



43 Aluminium

### Rail Powder-Coated

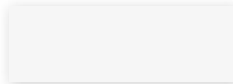

38 Snow



05 Black



# Panton Wire

Design: Verner Panton

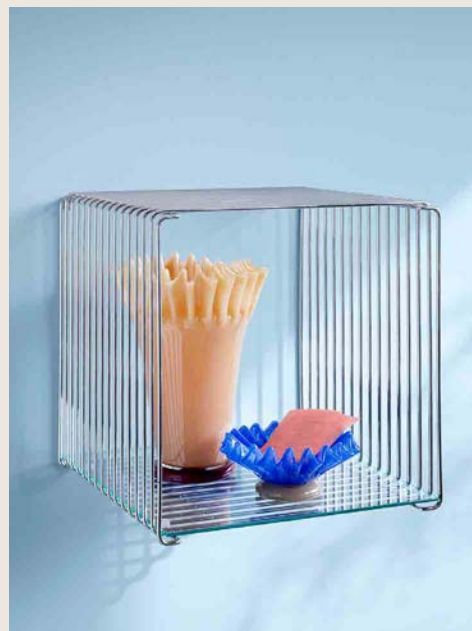

## Wire Shelf

Panton Wire modules, designed by Verner Panton in 1971, combine raw industrial aesthetics with a light and elegant appearance. The wire shelves are available in various depths and colours and can be used individually or in combination – on the floor, wall, or as a room divider.

### Technical Information

Panton Wire is made from 5 mm wire and is supplied with feet and clips for assembly, as well as 2 wall mounting brackets. For added functionality, the shelf can be equipped with a 4 mm glass shelf or 12 mm MDF shelves. Additionally, there are 12 mm top panels, designed for either one or two modules, in white and black marble or lacquered MDF, providing the option for a personal expression. Supplied with 1 set of shelf supports in transparent plastic.

### Load Capacity

Panton Wire W: 34.8 cm can be loaded with a maximum of 40 kg on the floor and up to 10 kg on the wall when mounted with the wall brackets. Panton Wire W: 70 cm can be loaded with a maximum of 10 kg evenly distributed on both the top and bottom, both on the floor and on the wall. When the module is inserted into setups, shelf plates are recommended for reinforcement.

# Panton Wire overview

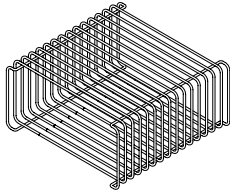

**76617 D35**

W 34,8 x H 17,2 x D 34,8 cm

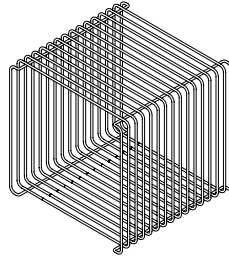

**6161T D35**

W 34,8 x H 34,8 x D 34,8 cm

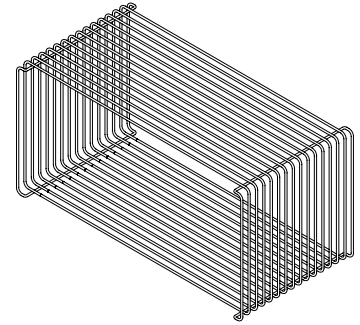

**6111T D35**

W 70 x H 34,8 x D 34,8 cm

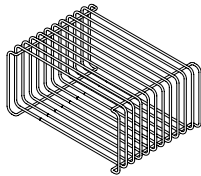

**7661T D26**

W 34,8 x H 17,2 x D 25,7cm

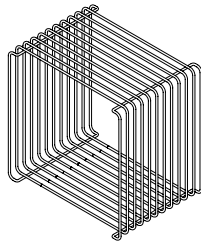

**6161T D26**

W 34,8 x H 34,8 x D 25,7 cm

6161T in D: 20 cm: While stocks last.

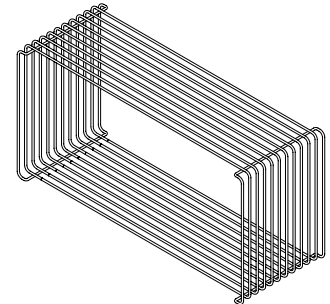

**6111T D26**

W 70 x H 34,8 x D 25,7 cm

6111T in D: 20 cm: While stocks last.



**Components**

104



**Surfaces**

105

# Panton Wire components



## Shelf - MDF

Shelves in 12 mm lacquered MDF.

**VPW6X:** W: 33 cm x D: 18.8/25.7/34.8 cm in D: 20\*/26/35.

**VPW12X:** W: 68.2 cm x D: 18.8/25.7/34.8 cm in D: 20\*/26/35.

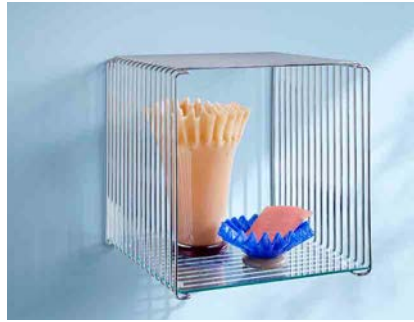

## Shelf - Clear Glass

Shelves in 4 mm clear glass.

**VPW6X:** W: 33 cm x D: 18.8/25.7/34.8 cm in D: 20\*/26/35.

**VPW12X:** W: 68.2 cm x D: 18.8/25.7/34.8 cm in D: 20\*/26/35.



## Top Panel

12 mm top panels for wire shelves.

Available in white and black marble or lacquered MDF. Supplied with 1 set of shelf supports in transparent plastic.

**VPWT1:** W: 34.8 cm. Fits 1 x Wire in D: 20\*/26/35.

**VPWT2:** W: 70.1 cm. Fits 2 x Wire in extension of each other in D: 20\*/26/35.



## Shelf Supports

**GTWIRE:** Set of 4 shelf supports for glass shelves and top panels sold separately. Available in transparent plastic.



## Clips

**CLWIRE:** Set of 4 clips for horizontal and vertical assembly of 1 Panton Wire. Black and Snow are supplied in plastic, while Chrome and Rosehip are supplied in lacquered Metal.



## Wall Mounting

**OPT:** Wall mounting, 2 pieces per module. Available in steel or lacquered in the module's colours.



## Feet

**SHWIRE:** Set of 4 feet for supporting the Wire. Available in Black and Snow.

\*Products in D: 20 are sold while stocks last.

# Panton Wire surfaces

## Materials

Panton Wire is made from 5 mm wire and is supplied with feet, clips for assembly, and 2 wall mounting brackets.

## Shelves and Top Panels

The wire shelving unit can be fitted with 4 mm glass shelves or 12 mm MDF shelves. 12 mm top panels are available for Panton Wire, designed for either 1 or 2 modules. Top panels are available in white and black marble or lacquered MDF. Supplied with 1 set of shelf supports in transparent plastic.

### Wire Shelf Chrome



Chrome Chrome 44C

### Wire Shelf Powder-Coated

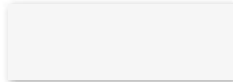

Powder Coat 38 Snow



Powder Coat 05 Black



Powder Coat 07 Black Red\*



Powder Coat 135 Monarch



Powder Coat 136 Pine



Powder Coat 145 Rosehip\*

### Shelves and Top Panels Lacquered MDF

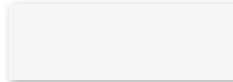

Lacquered 38 Snow



Lacquered 05 Black



Lacquered 07 Black Red\*



Lacquered 135 Monarch



Lacquered 136 Pine



Lacquered 145 Rosehip\*

### Shelves

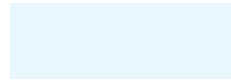

Clear Glass 99 - 4 mm

### Top Panels Marble



Marble Bianco Carrara  
Hvid 992



Marble Nero Marquina  
sort 995

\*Depth 20 is not available in the colors: 07 Black Red, 145 Rosehip, and is only sold while stocks last.

Please note that printed colours may differ from the original colour.



# System CO16

16 mm MDF / Design: Peter J. Lassen



## Office Modules

The Montana System CO16 is a modular interior system that meets the flexibility requirements of modern office environments. The modules can be used for storage at workstations or function as room dividers that create structure in open office landscapes. The system is made from 16 mm lacquered MDF and is available in all of Montana's lacquer colours, allowing the solution to be tailored to the company's aesthetic and needs.

# Montana CO16 overview

---

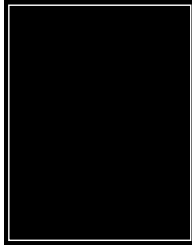

**Base- and Shelving Modules** 108

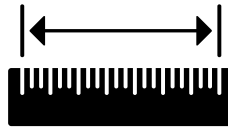

**Montana System - Star System and Measurements** 110

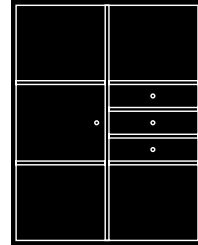

**Modules** 112 - 113

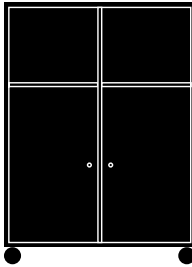

**Modules on Castors** 114

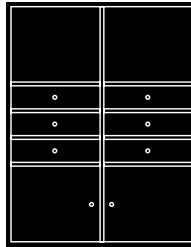

**Components** 115



**Surfaces** 122

# Montana CO16

EU ECOLABEL CERTIFIED

## Base and Shelving Modules

The Montana System CO16 consists of 11 base modules in 2 depths, made from 16 mm MDF for larger modules that can support more load. The following pages show shelving modules that can be combined for setups. The shelving modules can also be customised to individual preferences and needs with the addition of extra components. It is possible to install castors under all CO16 shelving modules. Each module includes a transparent loose plastic base inside, which protects the bottom/shelf of the module.



## Good to Know

Below is a range of information that may be helpful when choosing the Montana System CO16.

### 11 Base Modules

The Montana System CO16 consists of 11 base modules in 2 depths. However, modules with a width of 121.7 cm (\*21) and a height of 36.2 cm (\*6) are only available in a depth of 38.8 cm. If you wish to design your own personalised modules, the base modules can be fitted with a wide range of different CO16 components.

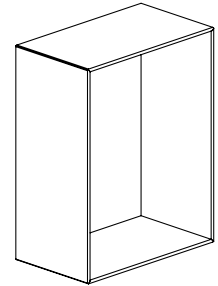
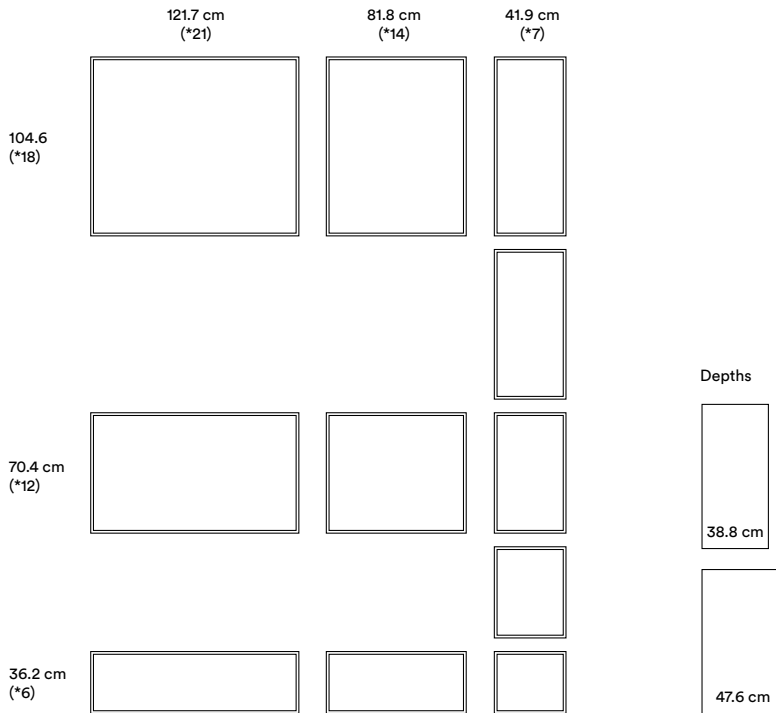

### Shelving Modules

The following pages present examples of configured shelving modules that can be combined for setups. The shelving modules can also be customised to meet your individual preferences and needs with the addition of extra components.

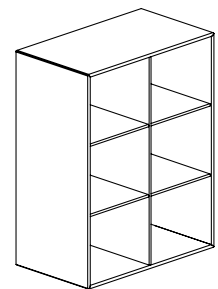

### Position

The shelving modules are delivered pre-assembled, ready to be placed on a plinth, legs, castors, a base plate with castors, or, when fitted with wall mounting brackets, ready to be mounted on the wall.

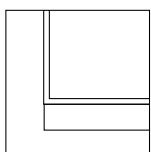

Plinth

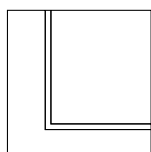

Wall-mounted

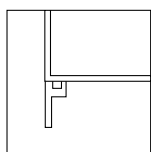

Legs

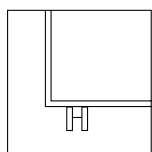

Castors

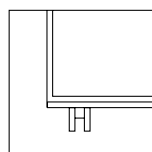

Base unit with castors



## ★ Star System and Measurements

With Montana's star system, you can easily find modules and components that fit together in size.

### CO16 Shelving System and Wardrobe

*Measurements	Internal	External
*1	4.5 cm	7.7 cm
*2	10.2 cm	13.4 cm
*3	15.9 cm	19.1 cm
*4	21.6 cm	24.8 cm
*5	27.3 cm	30.5 cm
*6	33.0 cm	36.2 cm
*7	38.7 cm	41.9 cm
*8	44.4 cm	47.6 cm
*9	50.1 cm	53.3 cm
*10	55.8 cm	59.0 cm
*11	61.5 cm	64.7 cm
*12	67.2 cm	70.4 cm
*13	72.9 cm	76.1 cm
*14	78.6 cm	81.8 cm
*15	84.3 cm	87.5 cm
*16	90.0 cm	93.2 cm
*17	95.7 cm	98.9 cm
*18	101.4 cm	104.6 cm
*19	107.1 cm	110.3 cm
*20	112.8 cm	116.0 cm
*21	118.5 cm	121.7 cm

### Internal Depth

When choosing shelving modules, it can be useful to know the internal depth of open modules and the depth behind doors. In the table below, the internal measurements are provided for the two module depths in the Montana System CO16. Each module includes a transparent loose plastic base inside, which protects the bottom/shelf of the module.

Module Depth	Internal measurements in open shelves	Internal measurements behind doors	Internal measurements behind sliding doors
38.8 cm	37.3 cm	34.3 cm	33.0 cm
47.6 cm	46.1 cm	43.1 cm	41.8 cm



### Internal Drawer Measurements (Usable Space) and Trays

Drawers	W x H	Depth 38	Depth 46
Tray 71	W: 36.1 x H: 2.9 cm	32.9 cm	
Tray 71S	W: 36.1 x H: 2.9 cm	24.9 cm	
Drawer 72PR	W: 35.4 x H: 6.6 (5) cm	31.3 cm	40.1 cm
Drawer 73PR	W: 35.4 x H: 12.3 (10.8) cm	31.3 cm	40.1 cm
Drawer 76PR	W: 35.4* x H: 29.2 (27.7) cm	31.3 cm	40.1 cm
Drawer 72X	W: 35.4 x H: 6.6 (5) cm	30.1 cm	38.9 cm
Drawer 73X	W: 35.4 x H: 12.3 (10.8) cm	30.1 cm	38.9 cm
Drawer 76X	W: 35.4 x H: 29.2 (27.7) cm	30.1 cm	38.9 cm

\* Filing Drawer 76PR (32.5 cm). 76X (33.1 cm)

Height measurements are from the drawer base to the top drawer front; measurements in parentheses indicate the height of the sides and back panel.

	121,7 cm (*21)	81,8 cm (*14)	81,8 cm (*14)	81,8 cm (*14)	81,8 cm (*14)
104,6 (*18)	 KH11	 KN11	 KN12	 KN13	 KN11S
104,6 (*18)	 KH12	 KN1211	 KN1213	 KN1214	 KN1215/KN2215
104,6 (*18)	 KH1210	 KN1216	 KN1220		
					KN1214: only D: 38 cm D: 38,8 cm D: 47,6 cm
70,4 cm (*12)	 PH11	 PN11	 PN12	 PN11S	 PN1211
70,4 cm (*12)	 PH12	 PN1212	 PN1213/PN2213	 PN1214	
					PN1214: only D: 38 cm D: 38,8 cm D: 47,6 cm
36,2 cm (*6)	 SH11	 SN11	 SN12	 SN11S	 SN1211
36,2 cm (*6)	 SH12	 SN1210/SN2210			
					D: 38,8 cm

Modules KN1215, PN1212, PN1213, and SN1210 are equipped with X drawers, including a pull-out barrier.  
 Modules KN2215, PN2212, PN2213, and SN2210 are equipped with PR drawers without a pull-out barrier.

### ▼ Signatures

Base Modules	Shelves	Fixed Shelves	Hidden Fixed Shelves	Doors	Sliding Doors	Magazine Shelves	Drawers	Trays

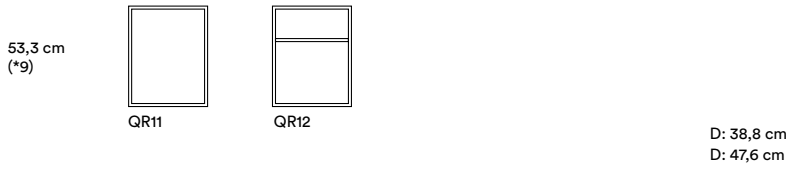
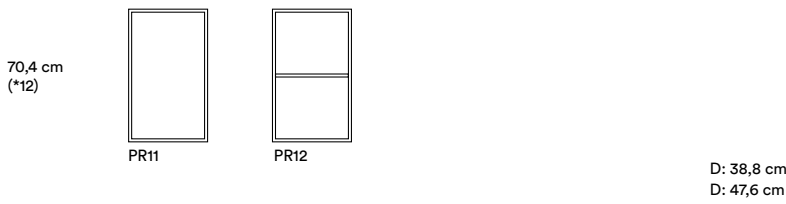
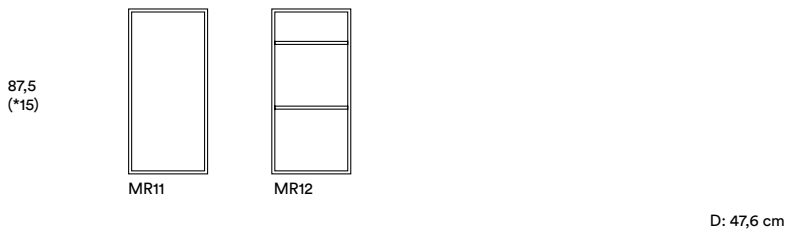
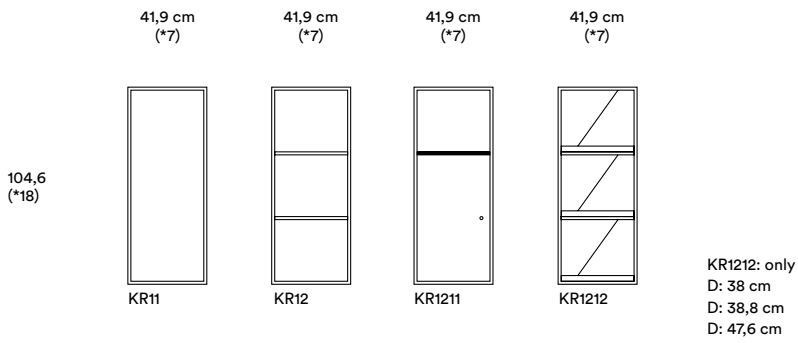

▼ Signatures

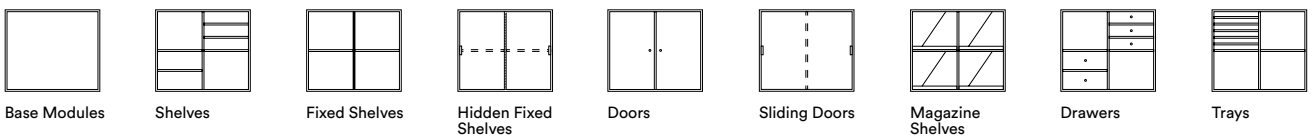

## Shelving Units with Castors

It is possible to mount castors under all CO16 shelving modules. Below are examples of mobile filing units, where the module is fitted with 4 CR castors, all with brakes. Modules with a width of 121.7 cm (\*21) are equipped with an additional castor in the middle, and modules with a width of 81.8 cm (\*14) are equipped with a support rail. The modules are available in a depth of 38.8 cm in all lacquer colours.

Modules KN1202, KN1204, PN1203, and PN1204 are equipped with X drawers, including a pull-out barrier.

Modules KN2202, KN2204, PN2203, and PN2204 are equipped with PR drawers without a pull-out barrier.

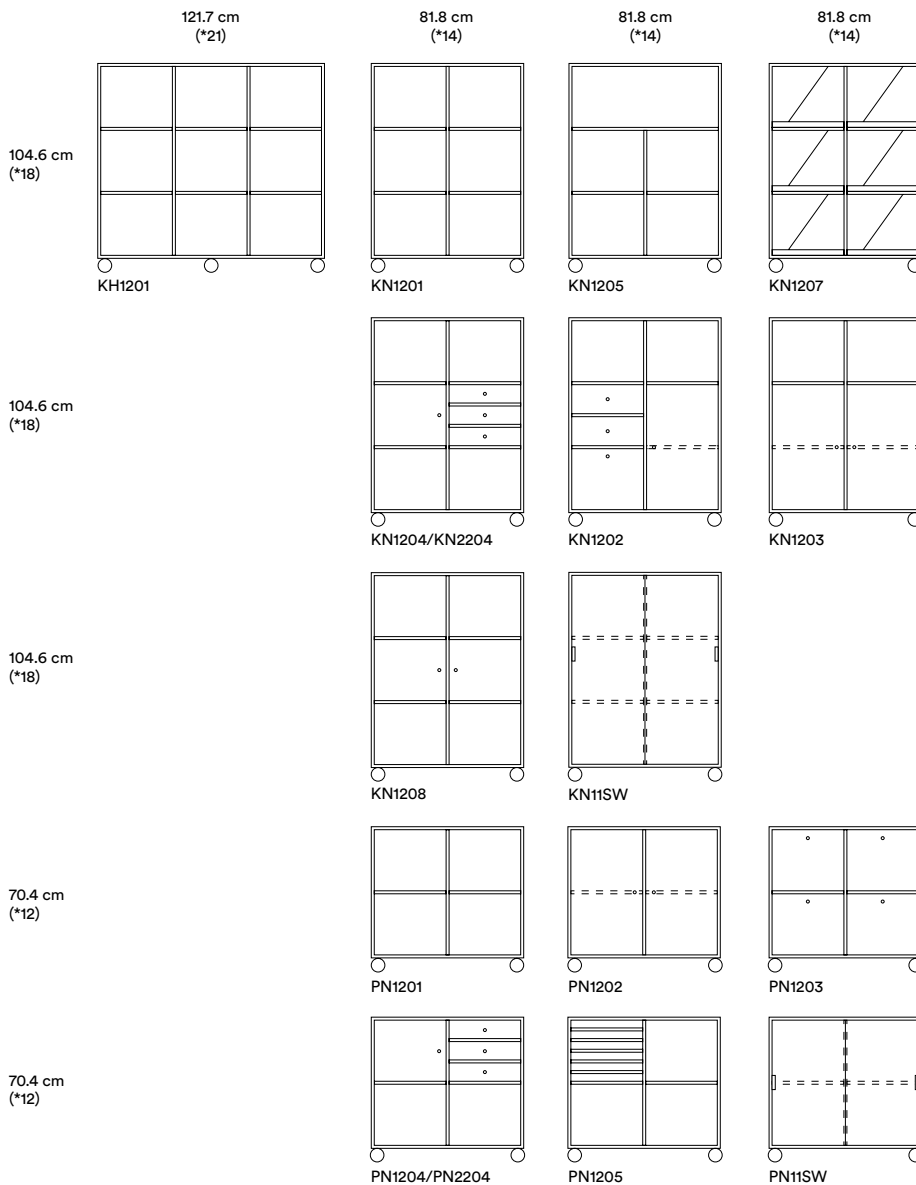
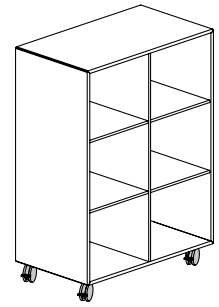



# System CO16

EU ECOLABEL CERTIFIED

## CO16 Components

A wide range of components allows you to customise the Montana System CO16 to meet your company's specific needs. Start with the base modules and build a shelving unit from scratch, or add extra functionality to an existing module with the available components.



# CO16 components



## Tray

**71 Tray:** 12 mm lacquered MDF.  
Base: 3.2 mm MDF.

Mounted on tray rails in either black or white plastic, which are fixed in the mounting holes. Trays can be completely removed from the module.

Internal dimensions: W: 36.1 cm, H: 3.1 cm, D: 32.9 cm (38.8).



## CO16 Drawers

Internal dimensions:

**71X:** H: \*1. Pen tray H: 1.9 cm

**72X:** H: \*2. W: 33.1 cm x H: 6.6 cm x D: (38.8) 30.1 cm, (47.6) 38.9 cm

**73X:** H: \*3. W: 33.1 cm x H: 12.3 cm x D: (38.8) 30.1 cm, (47.6) 38.9 cm.

4-sided drawer casing in white-pigmented beech wood. The drawer has 100% pull-out, self-closing, and soft-close. Includes a pull-out barrier. Additional cost for coloured handles. CO16 drawers can be mounted with central lock L3.

See all drawers-Usable Space on page 111 >

See locks on page 118 >



## Filing Drawer CO16

Drawers are available in all lacquer colours. The drawer includes a rail for hanging files.

Internal dimensions:

**76X:** H: \*6. W: 33.1 cm x H: 27.5 cm x D: (38.8) 30.1 cm, (47.6) 38.9 cm.

4-sided drawer casing in white-pigmented beech wood. The drawer has 100% pull-out, self-closing, and soft-close. Includes a pull-out barrier. Additional cost for coloured handles. CO16 drawers can be mounted with central lock L3.

See locks on page 118 >



## Project Drawers

**72PR:** H: \*2. W: 35.4 cm x H: 7.6 cm x D: (38.8) 31.3 cm, (47.6) 40.1 cm

**73PR:** H: \*3. W: 35.4 cm x H: 13.3 cm x D: (38.8) 31.3 cm, (47.6) 40.1 cm

3-sided drawer casing in white-pigmented beech wood. The drawer has 100% pull-out, self-closing, and soft-close.

Project drawers can be mounted with lock L1. A shelf or module top must be placed above a drawer when it is mounted with a lock.

Additional cost for coloured handles.



## Doors

16 mm MDF lacquered with water-based lacquer.

Additional cost for coloured handles.

**76:** W: \*7 x H: \*6

**712L:** W: \*7 x H: \*12

**718L:** W: \*7 x H: \*18

# CO16 components



## Shelves/dividers

The shelf is made of 12 mm lacquered or veneered MDF board. When ordering, please specify whether the shelf is to be used in an open module or behind a door, as well as which generation.



## Protective Plastic for Shelves

**PLAST6:** Protective plastic sheet for shelves. Designed to prevent wear from binders. The protective sheet is transparent and placed loosely on the shelf. It can be adapted to shelves in open modules and shelves behind doors.

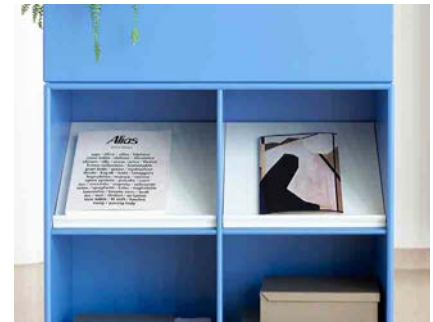

## Magazine Shelf

Angled shelf for magazines and brochures. Available in all lacquer colours. The shelf is mounted on two pins at the top and rests on the bottom or a fixed shelf at the bottom. D: 38: Shelf depth is 39.8 cm. Minimum clearance height: 27.3 cm (\*5).



## Top Panels, Glass

Top panels – 12 mm clear glass (iron-free). Front and back edges: rounded. End edges: straight. When a top panel is to cover multiple modules, an additional 1 mm per module is calculated. Glass top panels are not tempered.

Available from a length of 35.4 cm to 290 cm.

Available in depths from 18 cm to 120 cm.



## Top Panels, Glass with Lacquer

Top panels – 12 mm clear glass with lacquer (iron-free). Front and back edges: rounded. End edges: straight. When a top panel is to cover multiple modules, an additional 1 mm per module is calculated. Available from a length of 35.4 cm to 290 cm. Available in depths from 18 cm to 120 cm.

Glass top panels with lacquered underside have a lighter tone compared to lacquered MDF surfaces, as the lacquer colour is visible through the 12 mm glass. Top panels are supplied with slip protectors.



## Top Panels 16 mm

Front and back edges: Rounded. End edges: Straight. When a top panel is to cover multiple modules, an additional 1 mm per module is calculated. Available from a length of 30 cm to 240 cm. Available in depths from 20 cm to 120 cm.

**Please note:** The edges are coloured MDF to match the selected surface colour. Top panels are supplied with slip protectors. Assembly with notch and tongue.

Additional charge for assembly with notch and tongue. 1 = SAMNOT at one end. 2 = SAMNOT at both ends.

See TOP16 surfaces on page 122 >

# CO16 components

---



## Key Locks

**L1:** For doors and PR-drawers (with integrated handle function). Can be ordered with different lock numbers/serial numbers. For reorders, please specify the exact lock number/serial number. When installing lock L1 in a drawer, there must be a top panel/shelf above the drawer.

**L3:** Central locking system. Can be mounted in all X-drawers except 71X (pen tray) in D: 38 cm. Can be ordered with different lock numbers/serial numbers. For reorders, please specify the lock number/serial number. Not sold separately.



## Key Lock for Sliding Doors

**L6:** System lock that locks both sliding doors.

Locks by pressing in the lock core and turning it. Can be ordered with different lock numbers/serial numbers. For reorders, please specify the lock number/series.



## Accessories for Key Locks

**KEY:** Loose key. 1 pc.

**LK:** Loose core.

**SK1:** Service key. Used to replace the lock cylinder.

**MK1:** Master key. Opens locks with all lock codes. Please specify the serial number when ordering. Series 1: code 1–200, Series 2: code 201–600, Series 3: 601–2,600.

# CO16 components



## Combination Lock

**LCODE:** 4-digit combination lock for modules, Cargo units, and sliding doors. Available as either Fixed or Free code versions.

- **Fixed code:** The code remains the same and is typically used by one designated user.
- **Free code:** Ideal for shared environments where users choose a temporary code for short-term use.

When ordering as a loose item, please specify whether the lock should be Free or Fixed, and whether it will be installed on a hinged door, sliding door, or Cargo unit.

Both lock types feature an emergency access function. The product is covered by a 1-year warranty.

**MASKEY:** Universal master key for emergency opening of combination locks. Compatible with both Fixed and Free code versions.



## Electronic Lock

**ELLOK:** Battery-powered electronic lock for modules, Cargo units, and sliding doors. Powered by 1 x CR123A battery. The lock is delivered in factory mode and must be programmed by the customer. It can be set up for either Fixed or Free-code use.

- **ELLOK1:** For standard modules
- **ELLOK2:** For sliding door modules
- **ELLOK3:** For Cargo modules

The product includes a 1-year warranty.

**Note:** If the customer already uses an electronic locking system, their access card must be tested for compatibility with this lock.



## Card for Electronic Lock

**BASSET:** 2 x Master card, 1 x Service key, and 1 x Update. Supplied with each order.

**MASCRD:** Copy of master card. When ordering a copy of the master card for an existing lock system, it is important to state the system's ID number, which can be found on the Service key card.

**INSCRD:** Installation card supplied with each order. Used when the lock is in factory mode.

**PROSET:** 1 x Programming card, 1 x Sound, 1 x Reset, and 1 x Mode. Supplied with each order.

**USRSET:** 10 x User cards. One card per lock – if the customer has their own cards, the user card is omitted.

**OP4CRD:** Card for programming auto-lock. Can only be used with an ELLOK1 lock.

The product comes with a 1-year warranty.

# CO16 components



## Handles

**G6:** Aluminium or lacquered aluminium. Ø14 mm.

**G7:** Montana handle with a clear frosted acrylic disc. L: 16 mm, Ø12 mm. Supplied as standard in aluminium. Available in all Montana lacquer colours – please specify colour when ordering.



## Castors and Legs

CR castors, SR castors, SRCO castors, CR70 castors, and MB126 (legs).

Read more about all our castors and legs on page 20 >



## Base Units and Castors

**BAS22:** The base units are made of 22 mm MDF with rounded front and rear edges and straight ends.

Mounted with robust SR, SRCO, or CR castors. Supplied as standard with SR castors.

The centre of the castors is positioned 45 mm from the ends and long edges.

**NB: The castor guidelines are indicative.** The precise number of castors should be determined based on the specific configuration. As a minimum, one set of castors should be calculated per module that connects to another. For base units with a depth of less than 40 cm, there may be a risk of tipping. It is recommended to secure configurations on base units directly to the base and to link the modules together.

CR70 castors or legs cannot be mounted under a base unit.



## Waste Insert

Additional price for selecting waste insert for CO16 modules in W: \*7, \*14, and \*21, D: 38.8 cm.

Fits behind 712L door (W:\*7 x H:\*12) and 718 door (W:\*7 x H:\*18).

Cut-out with aluminium cover Ø15 cm is centred in the module top.

Supplied with 1 x 40-litre basket in white plastic, H: 50.3 x D: 27.3 x W: 32 cm.



## Living Things CO16

**FLOW14:** W: 81.8 cm (\*14) x H: 30 cm x D: 38.8 cm. Internal measurements: W: 78.6 cm x H: 28.7 cm x D: 35.5 cm. If the module is used for plants, it is recommended to use the FLOB14 plastic tray. Plants must always be placed in a waterproof undertray, and any spilled water in the module must be wiped up immediately.

**FLOB14:** Plastic tray with a height of 3 cm, which further contributes to the module's water resistance.

To place the module on top of configurations, it is produced with a podium base and supplied with 8 transparent knobs Ø8 x 1.5 mm.

Cannot be mounted with suspension rail or on a plinth.

# CO16 components

---



## Mounting Bracket, Standard

**OP12:** Mounting bracket for 12 mm, available in various versions to fit all module sizes.

The bracket features horizontal adjustment and is supplied with fittings and spacers for wall adjustment.

Modules in W: 121.7 (\*21) x H: 104.6 cm (\*18) cannot be mounted with bracket.

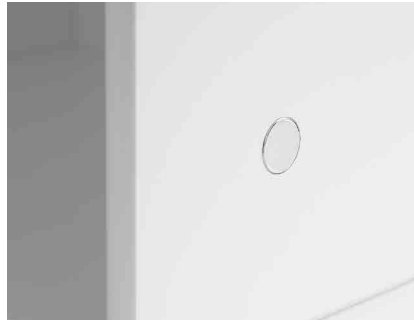

## Magnetic Coupling

Magnetic coupling of CO16 shelving modules with castors. The modules are mounted with two strong magnets at the top and two strong magnets at the bottom on each side, approx. 65 mm from the top, front and rear edge.

Electronics, mobile phones, watches, etc. should be kept at a minimum distance of 15 cm from the magnets, as the strong magnetic force may damage the devices.



## Support Rails

**SS10:** Mounted in open modules in W: 81.8 cm (\*14) without vertical divider. The rail is lacquered in the same colour as the shelving modules. Shelves/top can carry a max. load of 10 kg with the support rail.

**SSCO16:** Mounted under shelving modules in W: 81.8 cm (\*14) with castors or legs. The rail is always supplied in zinc-plated aluminium.

**SS20:** Mounted under modules in W: 121.7 cm (\*21) with castors and legs.

# System CO16 TOP16 surfaces

## Top Panels – 16 mm

**Front and back edges:** Rounded.

**End edges:** Straight.

When a top panel is intended to span multiple modules, add 1 mm per module to the total length.

Available lengths: 30 cm to 240 cm. Available depths: 20 cm to 120 cm.

### Linoleum



**Linoleum**  
Mushroom / Forbo 4176



**Linoleum**  
Ash / Forbo 4132



**Linoleum**  
Charcoal / Forbo 4166



**Linoleum**  
Nero / Forbo 4023



**Linoleum**  
Mauve / Forbo 4172



**Linoleum**  
Burgundy / Forbo 4154



**Linoleum**  
Pistachio / Forbo 4183



**Linoleum**  
Olive / Forbo 4184



**Linoleum**  
Walnut / Forbo 4003

### Laminate

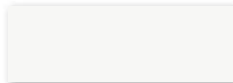

**Laminate** 38L Snow Silk

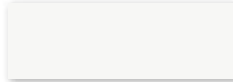

**Laminate** 38L Snow



**Laminate** 09L Nordic



**Laminate** 02L Fjord



**Laminate** 04L Anthracite



**Laminate** 157L Cumin



**Laminate** F3050L Cygnet



**Laminate** F8240L Liquid glass

### Veneer



**Veneer** White Oak 131F



**Veneer** Nature Oak 62F



**Veneer** Black Oak 133F

# System CO16 surfaces

## Materials

CO16 modules are made of 16 mm lacquered MDF. Drawers are internally constructed with drawer sides in white-pigmented solid wood and a base in white lacquered MDF.

## Lacquered MDF and glass top panels

Montana CO16 modules and glass top panels with lacquered backside are available in all of Montana's lacquer colours.



## Legs

CO16 available in all of Montana's lacquer colours, matt chrome-plated zinc, and brass.

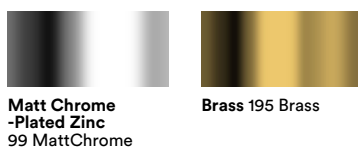



# Office Units

12 mm MDF / Design: Peter J. Lassen



## Mobile Storage for the Workstation

Montana Office Units are a flexible storage solution designed for workstations. The modules on castors are available in various versions with shelves, doors, drawers, and pen trays, making it easy to organise work tools and create a functional and personalised workspace.

### Technical Information

Office Units in 12 mm MDF, available in all of Montana's lacquer colours. The modules are available in D: 38 cm and 46.8 cm and are fitted with CR70 castors. Drawer fronts in 12 mm lacquered MDF with white-pigmented drawer sides. For drawers in height 12.6 cm (\*2) and 18.3 cm (\*3), drawer dividers can be selected.

Office Unit 4177, 4178, and 4179 are only available in D: 38 cm and include a metal suspension rail for mounting under the tabletop. The bracket is available in Snow and Black.

# Office Units overview

---

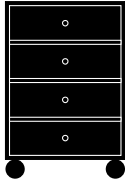

**Pre-designed**

126

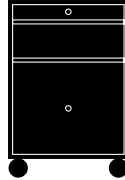

**Design your Own**

127

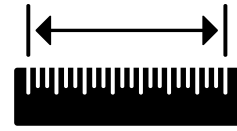

**Office Unit - Star System and Measurements**

128

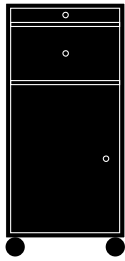

**Components**

129



**Surfaces**

131



# Office Units pre-designed

Office Units are available in depths of 38 and 46.8 cm, with CR70 castors.

Dimensions exclude castors. Castor height is: 6.8 cm.

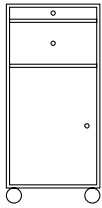

(\*12 x \*6)

**1368**

W 35,4 x H 69,6 cm

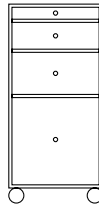

(\*12 x \*6)

**1369**

W 35,4 x H 69,6 cm



(\*8 x \*6)

**4165**

W 35,4 x H 46,8 cm

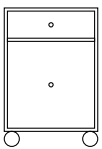

(\*8 x \*6)

**4166**

W 35,4 x H 46,8 cm

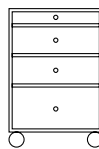

(\*8 x \*6)

**4269**

W 35,4 x H 46,8 cm

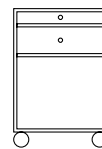

(\*8 x \*6)

**4270**

W 35,4 x H 46,8 cm

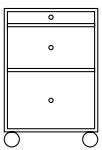

(\*8 x \*6)

**4271**

W 35,4 x H 46,8 cm



(\*8 x \*3)

**4178**

W 18,3 x H 46,8 cm



(\*8 x \*3)

**4179**

W 18,3 x H 46,8 cm



# Office Units design your own

Office Units are available in depths of 38 and 46.8 cm, with CR70 castors.

Dimensions exclude castors. Castor height is: 6.8 cm.

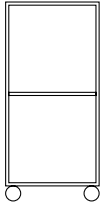

(\*12 x \*6)

**1360**

W 35,4 x H 69,6 cm



(\*8 x \*6)

**4160**

W 35,4 x H 46,8 cm



(\*8 x \*3)

**4177**

W 18,3 x H 46,8 cm

## ★ Star System and Measurements

Office Units are available in depths of 38 and 46.8 cm, with CR70 castors.

### Office Unit

*Dimensions	Internal	External
*3	15.9 cm	18.3 cm
*6	33.0 cm	35.4 cm
*8	44.4 cm	46.8 cm
*12	67.2 cm	69.6 cm

Dimensions exclude castors. Castor height is: 6.8 cm.

### Internal Drawer Measurements (Usable Space)

Skuffe	W x H	Dybde 38	Dybde 46
Drawers 62	W: 29.7 x H: 6.6 (5) cm	31.3 cm	40.1 cm
Drawers 63	W: 29.7 x H: 12.3 (10.8) cm	31.3 cm	40.1 cm
Drawers 64	W: 29.7 x H: 18 (10.8) cm	31.3 cm	40.1 cm
Drawers 66SK	W: 29.7 x H: 29.2 (27.7) cm	31.3 cm	40.1 cm

Height measurements are from drawer base to top drawer front; measurements in parentheses indicate the height of the sides and back panel.

With shadow list: add 1.2 cm to the height.

Pen trays 31PR and 61PR feature a white-lacquered tray in 22 mm MDF, with compartments of various sizes for storing writing utensils.

### L1 locks on Office Unit

On 4 of our Office Unit modules, an L1 lock can be installed.

For drawers, both handle and lock are included. The lock is flush with the front.

For doors (with built-in handle function).

The lock can be ordered with different lock numbers/serial numbers.

For reorders, please specify the lock number/series.

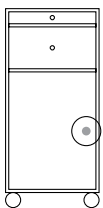

1368

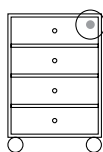

4165

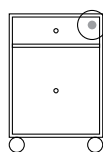

4166

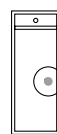

4179



# Office Units

EU ECOLABEL CERTIFIED

## Components

The Office Unit components are designed to support flexible, functional storage solutions in professional environments. The assortment includes doors, drawers, shelves, drawer dividers and lock options, allowing units to be tailored to different organisational needs, security requirements and spatial layouts. Together, the components make it possible to create both open and closed storage solutions that balance accessibility, structure and discretion in offices, shared workspaces and reception areas.



# Office Units components



## Shelves

**3X:** D: 38 cm

**6X:** D: 38 cm og D: 46 cm

Shelves are made of 12 mm lacquered MDF and are available in all of Montana's lacquer colours.

When ordering, please specify whether the shelf is to be used in an open shelving unit or behind a door.



## Doors

**37:** (\*3 x \*7)

**66:** (\*6 x \*6)

**68:** (\*6 x \*8)

Doors are made of 16 mm lacquered MDF with colour-matched edges and are available in all of Montana's lacquer colours.

Additional price for coloured handle.



## Drawers

**31PR:** W: \*3 x H: \*1. Pen tray H: 3 cm. Mounted on sliding lists.

**61PR:** W: \*6 x H: \*1. Pen tray H: 1,9 cm.

**62:** W: \*6 x H: \*2.

**63:** W: \*6 x H: \*3.

**64:** W: \*6 x H: \*4.

**66SK:** W: \*6 x H: \*6.

Drawer fronts are made of 12 mm lacquered MDF and are available in all of Montana's lacquer colours.

Drawer sides in white-pigmented beech wood. Drawer base in white MDF. Drawer extensions: free-running metal slides with soft-close and 100% extension.

**Additional price** for coloured handle. Cannot be retrofitted on 31PR and 61PR.



## Drawer Dividers

**621A**

**621B**

Drawer divider for drawers in width \*6 can be used for drawers in height \*2 and \*3. Height of the divider is 5.5 cm.

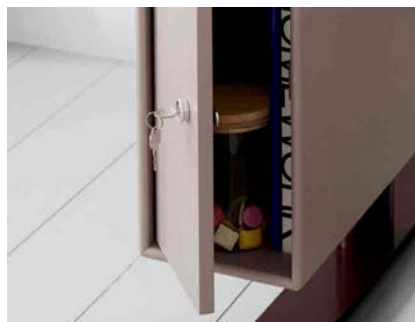

## Door Locks

**L1:** For door (with built-in handle function).

Can be ordered with different lock numbers/serial numbers. For reorders, please specify the lock number/series.

See which modules can be fitted with locks on page 128 >

For lock accessories, see page 118 >



## Drawer Locks

**L1:** For drawers. When installing lock L1 in a drawer, there must be a modular top/shelf above the drawer.

Can be ordered with different lock numbers/serial numbers. For reorders, please specify the lock number/series.

See which modules can be fitted with locks on page 128 >

For lock accessories, see page 118 >

# Office Units surfaces

## Materials

Office Units in 12 mm MDF. Drawers are internally constructed with white-pigmented solid wood drawer sides and a base in white lacquered MDF.

## Lacquered MDF

Montana Office Units are available in all of Montana's lacquer colours.



## Metal brackets

Metal brackets for modules 4177, 4178, and 4179

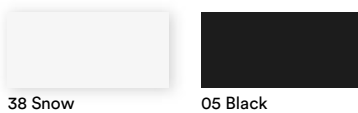



# Cargo

16 mm MDF / Design: Peter J. Lassen



## Storage and Room Divider on Castors

Cargo functions as personal storage or a room divider and is ideal for creating room and calm at the individual workplace. The interior design options of Montana Cargo are numerous, and the module can be fitted with a master key lock when used for personal storage.

### Technical Information

The Cargo module is available in widths of 80 cm and 90 cm in all of Montana's lacquer colours. The unit is equipped with soft-close, which, combined with two castors mounted under the shelving unit, ensures stable and smooth movement. Top modules in widths of 80 cm and 90 cm are available for Cargo modules. Cargo can be selected with extension direction to the right or left – or both.

Cargo is made of 16 mm MDF and is available in all of Montana's lacquer colours.

# Cargo overview

---

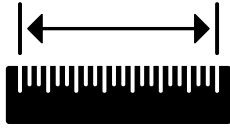

---

**Cargo System and  
Dimensions**

134

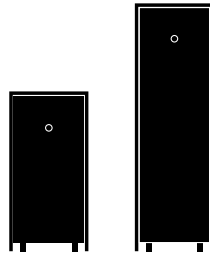

---

**Modules**

135

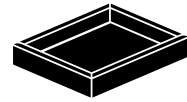

---

**Components**

136



---

**Surfaces**

139



## Cargo Modules

The shelving unit has an internal width of 70.4 cm (\*12) with full extension.

L/R indicates extension direction: left (L) and right (R). Right indicates that the module is placed on the user's right-hand side with the opening facing the user. Left indicates that the module is placed on the user's left-hand side with the opening facing the user.

Two-way Cargo modules can be accessed from both the left and right side. D indicates that a Cargo is two-way. Top modules for Cargo modules are available in widths of 80 cm and 90 cm, in two heights: 24.8 cm (\*4) and 36.2 cm (\*6).

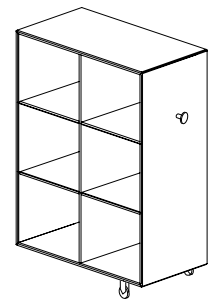

## Cargo width 80 cm and 90 cm

### Cargo width 80 cm

The internal measurements of the Cargo modules are W: 70.4 cm x H: 104.6 cm (\*12 x \*18) or W: 70.4 cm x H: 64.7 cm (\*12 x \*11) with a fixed depth of 32 cm. The external measurements of the Cargo parking unit are W: 80 or 90 cm x H: 74 cm (\*11) and H: 114 cm (\*18) x D: 36.4 cm.

### Cargo width 90 cm

The internal measurements of the Cargo modules are W: 70.4 cm x H: 104.6 cm (\*12 x \*18) or W: 70.4 cm x H: 64.7 cm (\*12 x \*11) with a fixed depth of 32 cm. The external measurements of the Cargo parking unit are W: 80 or 90 cm x H: 74 cm (\*11) and H: 114 cm (\*18) x D: 36.4 cm.

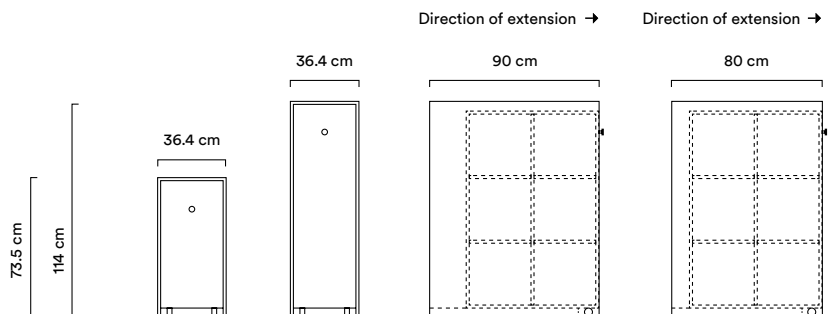
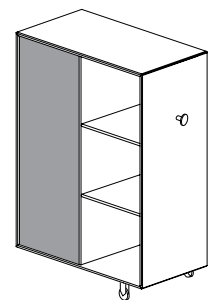

## Cargo components

Drawers and trays can be placed throughout the entire module. The interior design options of Montana Cargo are numerous, and the module can be fitted with a master key lock when used for personal storage.

# Cargo modules

The Cargo parking unit is available in W: 80 cm and W: 90 cm. The module is the same. Read more on page 134 >

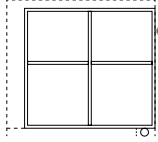

Front: W: 36,4 cm (\*11 x \*12)

**C2180L/R and C2190L/R** H 74 x D 80  
H 74 x D 90

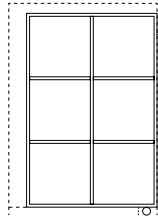

Front: W: 36,4 cm (\*18 x \*12)

**C2480L/R and C2490L/R** H 114 x D 80  
H 114 x D 90

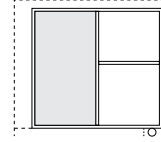

Front: W: 36,4 cm (\*11 x \*12)

**C2180D and C2190D** H 74 x D 80  
H 74 x D 90

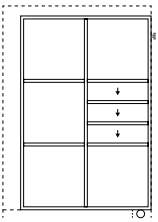

Front: W: 36,4 cm (\*18 x \*12)

**C2580L/R and C2590L/R** H 114 x D 80  
H 114 x D 90

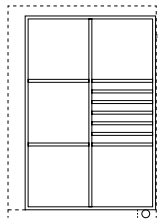

Front: W: 36,4 cm (\*18 x \*12)

**C2680L/R and C2690L/R** H 114 x D 80  
H 114 x D 90

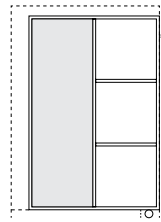

Front: W: 36,4 cm (\*18 x \*12)

**C2480D and C2490D** H 114 x D 80  
H 114 x D 90

## Top Modules for Cargo

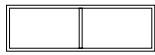

(H \*4)

**2180** 80 x 24.8 cm

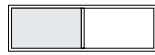

(H \*4)

**2180D** 80 x 24.8 cm

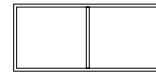

(H \*6)

**2181** 80 x 36.2 cm



(H \*6)

**2181D** 80 x 36.2cm

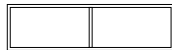

(H \*4)

**2190** 90 x 24.8 cm



(H \*4)

**2190D** 90 x 24.8 cm



(H \*6)

**2191** 90 x 36.2 cm



(H \*6)

**2191D** 90 x 36.2 cm

## Signatures ▶



Open module



Drawers without handles



Tray



Drawers without handles



# Cargo

EU ECOLABEL CERTIFIED

## Components

The Cargo system includes a flexible range of components that allow each unit to be adapted for personal storage or shared use. Drawers, trays and shelves support varied interior layouts, while doors, handles and lock options enable both open and secure storage solutions. Together, the components make it easy to configure Cargo to different functional needs in the workplace.



# Cargo components



## Handles

**5X:** D: 32 cm

**6X:** D: 32 cm.

The shelf is made of 12 mm MDF and is available in all of Montana's lacquer colours.

When ordering, please specify whether the shelf is to be used in an open shelving unit or behind a door.



## Tray for Cargo

**61:** Internal measurement W: 30.2 cm x H: 3.1 cm x D: (30.3) 24.9 cm.

Trays are made of 12 mm lacquered MDF and are available in all of Montana's lacquer colours. Base: 5.5 mm MDF.

Trays can be placed throughout the entire module.



## Drawers for Cargo

**62BSD:** Internal measurement W: 29.7 cm x H: 7.6 cm x D: (30.3) 23.3 cm.

The drawer features push function and is available in all of Montana's lacquer colours.

Drawer sides in white-pigmented beech wood. Drawer base in colour 100 Graphic.

Drawers can be placed throughout the entire module.



## Door for Cargo

**66:** \*6 x \*6. Standard door, which can be mounted with an L1 lock.



## Handle

**G8:** Cylindrical shape Ø14 mm with flange Ø30 mm in aluminium. L: 21 mm.



## Lock for Cargo

**L8:** Can be ordered with different lock numbers/serial numbers. For reorders, please specify the lock number/series.

**NB!** If the Cargo is fitted with a master key lock, the top compartment with the lock case cannot be used for drawers or trays.

For lock accessories, see page 118 >

# Cargo components

---



## Code Lock

**LCODE:** Combination lock with 4 digits for modules, Cargo, and sliding door.

Available as fix or free code. A fix code is always the same and typically used by a single user.

Free code is suitable for environments where the unit is only used for a limited time, and users can freely choose between doors.

For direct purchase, it must be specified when ordering whether the lock should be free or fix, and whether it should be mounted in a door, sliding door, or Cargo.

Both locks have an emergency opening function. The product comes with a 1-year warranty.

For accessories for locks, see page 119 >



## Electronic Lock

**ELLOK:** Electronic battery lock for modules, Cargo, and sliding door. Battery type: 1x CR123A.

The battery lock is delivered in factory mode and must be coded by the customer. The lock can be coded for fix or free code.

**ELLOK3:** For Cargo module.

The product comes with a 1-year warranty.

For accessories for locks, see page 119 >

# Cargo surfaces

## Materials

All Montana Cargo inner modules and housings are made of 16 mm MDF. Drawers are internally constructed in white-pigmented solid wood, and pen trays in white lacquered MDF. The product comes with a 1-year warranty.

## Lacquered MDF

Cargo modules are available in all of Montana's lacquer colours.





# Lockers

16 mm MDF / Design: Peter J. Lassen



## Wardrobe and Staff Lockers

Montana Lockers are a space-saving storage solution that offers the possibility of personal storage in offices and other environments requiring individual lockers. Lockers are available in four standard sizes and can be customised to suit various layouts and functional needs.

### Technical Information

The modules are available in 4 sizes with depths of 38.8 cm and 47.6 cm, and can be mounted using either suspension or plinth. The suspension for the Montana Lockers module is reinforced and cannot be retrofitted. Plinths are available in a height of 7 cm and are specially reinforced. Supplied as standard with G7 handle and protective plastic sheet. Lockers are made of 16 mm MDF and are available in all of Montana's lacquer colours.

# Locker overview

Depth: 38,8 cm and 47,6 cm

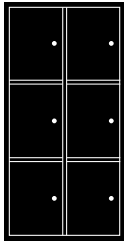

(\*12 x \*24)

**6 Rooms**

70,4 x 138,8 cm

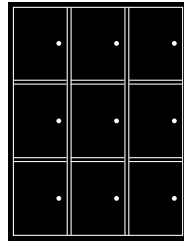

(\*18 x \*24)

**9 Rooms**

104,6 x 138,8 cm

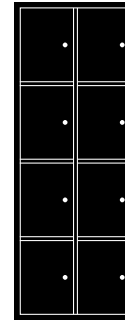

(\*12 x \*32)

**8 Rooms**

70,4 x 184,4 cm

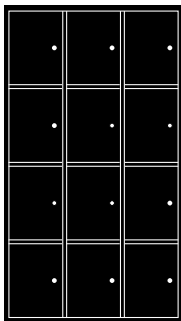

(\*18 x \*32)

**12 Rooms**

104,6 x 184,4 cm

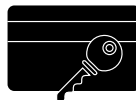

**Components**

142



**Surfaces**

145



# Lockers

EU ECOLABEL CERTIFIED

## Components

The Lockers system includes a focused range of components that support both secure and practical storage. Doors with optional letterbox function, numbering and a choice of key, combination or electronic locks allow each locker to be adapted to different usage scenarios. Reinforced plinths, suspension and protective shelf sheets complete the system, ensuring stable installation and long-term durability.



# Lockers components



## Doors

The doors on Lockers are available as standard doors or doors with letterbox function.

All doors on a Montana Lockers module are hinged on the same side – right or left.



## Door with Letterbox Function

**B 68BL:** The letterbox function is a 2 cm reduction at the top of the door, allowing mail to be inserted. Behind the door is a shelf that catches the mail. Locker doors are W: \*6 x H: \*8. All doors on a Montana Lockers module are hinged on the same side – right or left. Additional price for letterbox function per door.



## Numbering

**NUMLOK:** The numbering on the door is placed in the upper corner, opposite the hinge. The numbering is 3 cm high, medium grey, and visible on all Montana lacquers – and is only available in horizontal orientation. For electronic locks, the card is held over the number to activate the lock. Additional price for numbering per door. Standard numbering is three digits.

Supplied as standard in grey (Oracal 724 – Ice Grey). For direct purchase, it must be specified whether NUMLOK should be placed on the right or left side.



## Locks

Montana Lockers modules can be fitted with a key lock, combination lock, or electronic battery lock. The key lock replaces the G7 handle. The battery lock is operated with a chip card.



## Fitting Components

**L1207:** 7 cm plinth for locker module  
W: 70.4 cm (\*12)

**L1807:** 7 cm plinth for locker module  
W: 104.6 cm (\*18)

The effective plinth depths are 34 cm (D: 38.8 cm) and 44 cm (D: 47.6 cm).

**OPLOK1:** Suspension for locker module  
W: 70.4 cm (\*12)

**OPLOK2:** Suspension for locker module  
W: 104.6 cm (\*18)

Suspension for locker modules cannot be retrofitted.



## Protective Plastic for Shelves

**PLAST6:** Protective plastic sheet for shelves. Designed to prevent wear from binders. The protective sheet is transparent and placed loosely on the shelf. It can be adapted to shelves in open modules and shelves behind doors.

# Lockers components

---



## Manual Locks

**MANLOK:** For door (with built-in handle function).

Can be ordered with different lock numbers/serial numbers.

For reorders, please specify the lock number/series.

For lock accessories, see page 118 >



## Combination Lock

**LCODE:** Combination lock with 4 digits for modules, Cargo, and sliding doors. Available as fix or free code.

**A fix code** remains the same and is typically used by a single user.

**A free code** is suitable for environments where the locker is used for a limited time and allows free choice of doors.

For direct purchase, it must be specified when ordering whether the lock should be free or fix, and whether it will be mounted in a door, sliding door, or Cargo.

Both locks feature an emergency opening function.

The product comes with a 1-year warranty.

For lock accessories, see page 119 >



## Electronic Lock

**ELLOK:** Electronic battery lock for modules, Cargo, and sliding doors.

Battery type: 1 x CR123A.

The battery lock is delivered in factory mode and must be coded by the customer. The lock can be set to either fix or free code.

**ELLOK1:** For standard module.

The product comes with a 1-year warranty.

If the customer already uses an electronic lock system, their card must be tested on the electronic lock.

For lock accessories, see page 119 >

# Lockers surfaces

## Materials

Montana Lockers are made of 16 mm MDF and are available in all of Montana's lacquer colours.

## Lacquered MDF

Montana Lockers are available in all of Montana's lacquer colours.





# Contract Selections

12 and 16 mm MDF / Design: Peter J. Lassen



## Application Examples for Professional Spaces

The Montana Office Selections present a curated series of application examples that demonstrate how the Montana System can be used in professional environments. The configurations illustrate solutions for workplaces, meeting areas, reception zones, breakout spaces and shared facilities, showing how modular storage can support organisation, zoning, privacy and flow. Each selection is intended as inspiration and can be adjusted to meet specific functional, spatial or architectural requirements. Prices for the illustrated configurations are not listed in the standard price list; please request the Office Selections sales presentation for detailed pricing information.

# Office Selections pre-designed

**NOTE:** Module heights are shown excluding base options. Add 12.6 cm for legs, 6.8 cm for castors, and 3 or 7 cm for plinths. The configurations can be found in Design Pro in the "Inspiration" area or in the Pcon catalogue.

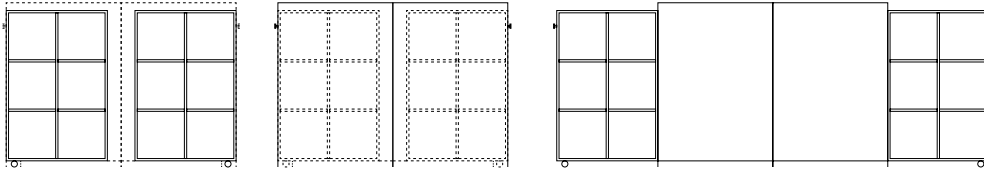

## WORKSTATION

### DESK DIVIDER

W 180 x H 114 x D 36.4 cm

CARGO with open storage to one side, in 16 mm MDF (C2490L/R). Each unit is 90 cm and fits two HiLow tables (depth 90 cm without acoustic screens, 80 cm with). See page 132 for inspiration on Cargo.

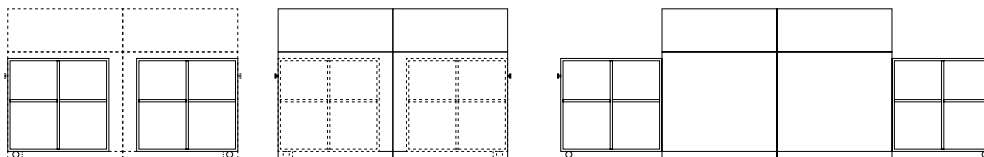

## WORKSTATION

### DESK DIVIDER

W 160 x H 103.5 x D 36.4 cm

Montana Cargo with open side storage (C2180L/R) in 16 mm MDF, combined with a planter unit on top for plants or additional storage. See page 132 for inspiration on Cargo.

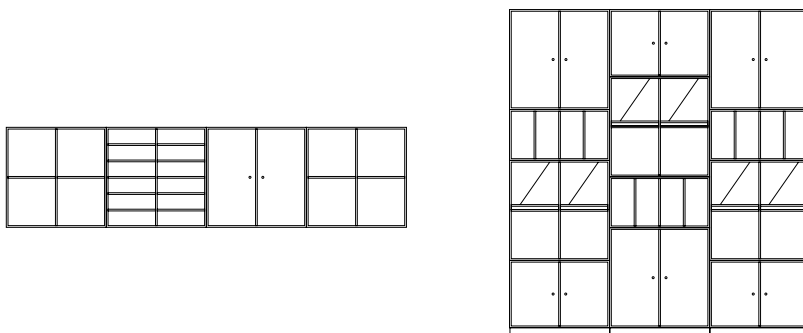

## WORKSTATION

### OFFICE STORAGE

W 278.4 x H 69.6 x D 38 cm

A wall-mounted configuration combining open and closed units, with one module fitted with sorting shelves for mail, documents, or daily office items. See page 8 for inspiration on the 12 mm System.

## WORKSTATION

### OFFICE STORAGE

W 69.6/208.8 x H 228.4 x D 38 cm

A substantial configuration on a plinth featuring open shelving, closed modules, and magazine shelves. See page 8 for inspiration on the 12 mm system.

# Office Selections pre-designed

**NOTE:** Module heights are shown excluding base options. Add 12.6 cm for legs, 6.8 cm for castors, and 3 or 7 cm for plinths. The configurations can be found in Design Pro in the "Inspiration" area or in the Pcon catalogue.

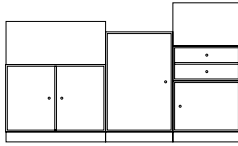

## WORKSTATION

### ROOM DIVIDERS

W 163.2 x H 96.4 x D 38 cm

A plinth-mounted storage with closed units in varying heights, combined with planters that add greenery. Made from 12 mm lacquered MDF. See page 8 for inspiration on the 12 mm system.

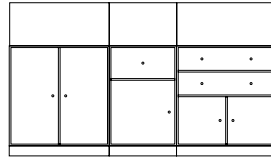

## WORKSTATION

### ROOM DIVIDERS

W 186 x H 106.6 x D 38 cm

A plinth-mounted configuration with closed storage and a planter on top for greenery or additional organisation. See page 8 for inspiration on the 12 mm system.

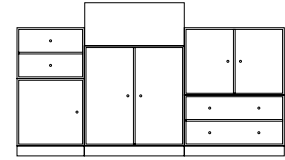

## WORKSTATION

### ROOM DIVIDERS

W 186 x H 106.6 x D 38 cm

A plinth-mounted configuration with closed storage and a planter on top for greenery or added organisation. See page 8 for inspiration on the 12 mm system.

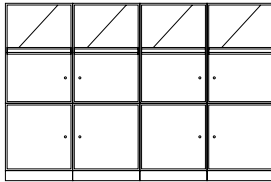

## WORKSTATION

### ROOM DIVIDERS

W 187.2 x H 123.4 x D 38 cm

A plinth-mounted configuration combining closed storage and magazine display shelves. See page 8 for inspiration on the 12 mm system.

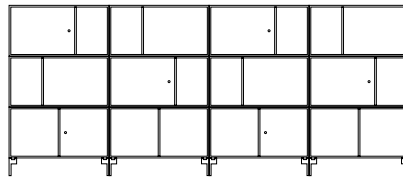

## WORKSTATION

### ROOM DIVIDERS

W 278.4 x H 118.8 x D 38 cm

A leg-mounted Montana System configuration featuring both open and closed modules for flexible storage and display. See page 8 for inspiration on the 12 mm system.

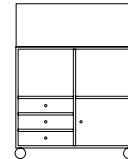

## MEETING

### DISPLAY

W 81.8 x H 109.6 x D 38.8 cm

Castor-mounted cabinets combining open and closed modules serve as both storage and a subtle room divider. See page 8 for inspiration on the 12 mm system.

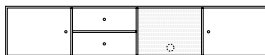

## MEETING

### TV & SOUND

W 183.6 x H 35.4 x D 30 cm

The wall-mounted Montana TV & Sound (SE13) features two doors, two drawers, and a perforated retractable metal door that allows remote control of electronics even when closed. See page 36 for inspiration on TV & Sound.



## MEETING

### TV & SOUND

W 183.6 x H 24 x D 30 cm

The wall-mounted Montana TV & Sound (VE15) offers open shelving and closed storage, with a perforated retractable metal door that allows electronics to function even when closed. See page 36 for inspiration on TV & Sound.



## MEETING

### TV & SOUND

W 278.8 x H 36.6 x D 30 cm

A wall-mounted Montana TV & Sound configuration featuring closed storage and a matching top panel. See page 36 for inspiration from the TV & Sound series.

# Montana Office Selections pre-designed

**NOTE:** Module heights are shown excluding base options. Add 12.6 cm for legs, 6.8 cm for castors, and 3 or 7 cm for plinths. The configurations can be found in Design Pro in the "Inspiration" area or in the Pcon catalogue.



## MEETING

### CABINET

W 69.6 x H 12.6 x D 30 cm

A wall-mounted Montana System configuration with two practical trays and a drawer for storing smaller items. See page 8 for inspiration on the 12 mm System.

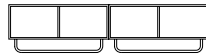

## WELCOME

### HALL

W 139.2 x H 32.9 x D 30 cm

In professional environments, two Montana modules with integrated coat rails below offer a streamlined alternative to a full wardrobe. See page 8 for inspiration on the 12 mm System.

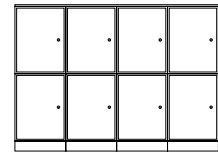

## WELCOME

### CABINET ISLAND

W 141.6 x H 100.6 x D 76 cm

Montana System cabinets can be configured as a storage island in the welcome area, finished with a lacquered MDF top plate. See page 8 for inspiration on the 12 mm System.

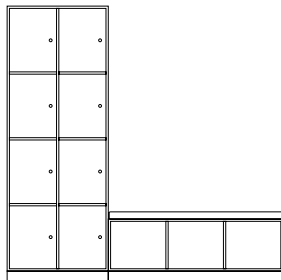

## WELCOME

### LOCKERS AND SEATING

W 192.5 x H 192.6 x D 38.8 cm

The Montana Locker module with eight individual compartments is paired with an open bench featuring shelving and a cushioned seat. See page 106 for inspiration on the Office System CO16 and page 140 for the Lockers.

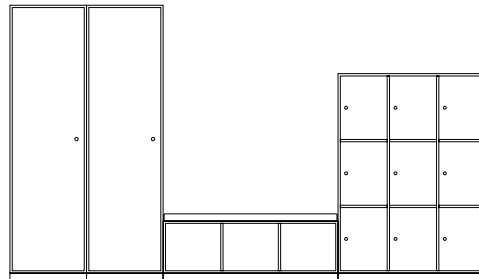

## WELCOME

### WARDROBE AND LOCKERS

W 333.7 x H 193.4 x D 38.8 cm

This setup combines a two-section Montana Wardrobe for coats, Montana Lockers with nine compartments, and a low storage unit with integrated seating. For inspiration, see page 68 for the Montana Wardrobe, page 106 for the Office System CO16, and page 140 for the Lockers.

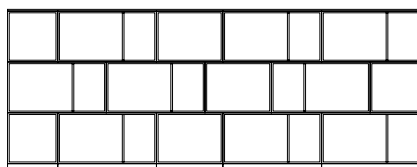
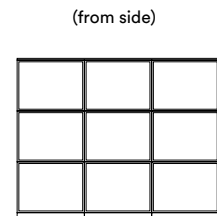

## WELCOME

### RECEPTION COUNTER

W 291 x H 113.2 x D 38 cm

A reception counter created with Montana Selection offers both flexibility and strong visual impact. See page 8 for inspiration on the 12 mm system.

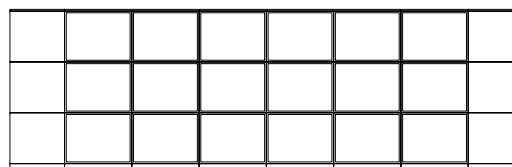

## WELCOME

### RECEPTION COUNTER

W 357.4 x H 114.4 x D 140.7 cm

Montana System on a plinth with storage cabinets and a glass top – ideal for a reception counter. See page 8 for inspiration on the 12 mm system.

# Montana Office Selections pre-designed

**NOTE:** Module heights are shown excluding base options. Add 12.6 cm for legs, 6.8 cm for castors, and 3 or 7 cm for plinths. The configurations can be found in Design Pro in the "Inspiration" area or in the Pcon catalogue.

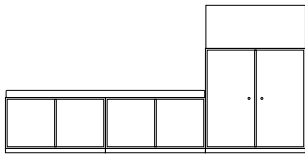

## BREAK OUT AREA

### SYSTEM SEATING

W 208.8 x H 102.6 x  
D 38 cm

This configuration combines a two-module seating bench with a bridging cushion for added comfort. See page 46 for inspiration on the System Seating. Design Pro ID: VIBLJ

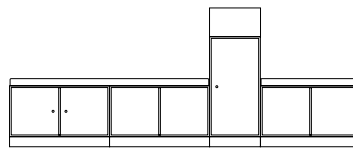

## BREAK OUT AREA

### SYSTEM SEATING

W 244.2 x H 96.6 x  
D 38 cm

Benches combining open and closed storage are positioned on either side of a tall cabinet topped with a planter. See page 46 for inspiration on the System Seating. Design Pro ID: FFNCB

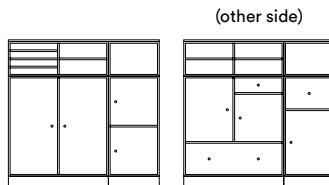
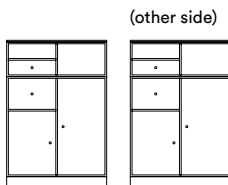

## WORKSHOP

### SMALL ISLAND

W 70.8 x H 101.8 x  
D 60 cm, plinth: 7 cm

Storage on a plinth with two doors, two drawers, and two open shelves. The units are topped with a lacquered glass panel. See page 8 for inspiration on the 12 mm system. Design Pro ID: JXSQT

## WORKSHOP

### MEDIUM ISLAND

W 105.2 x H 114.4 x  
D 93.6 cm

Montana system on a plinth with open and closed units for storage and display on both sides. The units are topped with a lacquered glass panel. See page 8 for inspiration on the 12 mm system. Design Pro ID: LHYAQ



## COFFEE STATION

W 140.7 x H 48 x D 38 cm

A wall-hung configuration serves as a compact coffee station, offering cabinet storage for coffee supplies, cups, and small appliances. See page 8 for inspiration on the 12 mm System. Design Pro ID: VTSFE

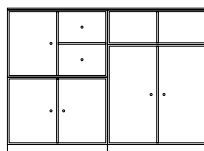

## COFFEE STATION

W 139.4 x H 101.8 x D 46.8 cm

A functional coffee station built from plinth-mounted modules with doors and drawers for neatly organising coffee supplies. See page 8 for inspiration on the 12 mm System. Design Pro ID: HHGIN

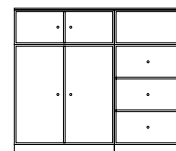

## COFFEE STATION

W 116.4 x H 35.4 x D 30 cm  
W 116.4 x H 100.6 x D 46.8 cm

A coffee station with plinth-mounted modules featuring doors and drawers for organised storage, combined with a wall-mounted module with rippled glass doors. See page 8 for inspiration on the 12 mm System. Design Pro ID: GKDXK

# Montana Office Selections surfaces

---

## Materials

Montana Office Selections are made of 16 mm MDF and are available in all of Montana's lacquer colours.

## Lacquered MDF

Montana Office Selections is available in all of Montana's lacquer colours.





# SEATING AND CHAIRS







# INDEX — Seating and Chairs

---

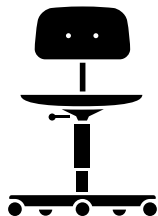

**Kevi**

156

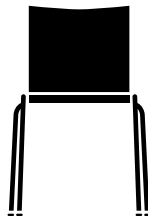

**Chairik**

172



**Marée**

188

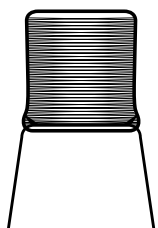

**Panton One**

194



**Joint**

200

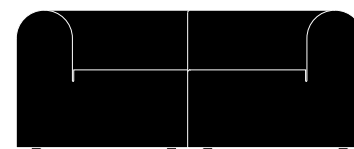

**Paradigm**

204

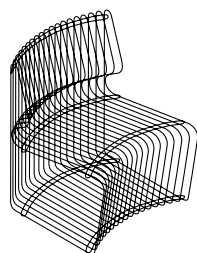

**Pantonova**

212

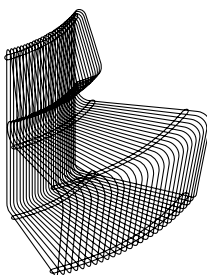

**Outdoor**

221



**Load Capacity Overview  
for Chairs**

218



# Kevi

14 models / Design: Jørgen Rasmussen



## Versatile Chair Series in Iconic Design

The Kevi chair was designed in 1958 by architect Jørgen Rasmussen and is known for its timeless design and high level of comfort.

With its simple and functional form, Kevi has become a classic that fits seamlessly into private homes, workplaces, and institutions.

Kevi is a versatile chair series that includes several models with different functionalities – from classic office chairs with castors to dining chairs, bar stools, lounge chairs, and stools. The series is available in a wide range of colours, textiles, and materials, allowing the chair to be tailored to individual needs and integrated into a harmonious interior.

### Technical Information

The Kevi chair family consists of models on castors in 4 heights and various versions. The four-legged Kevi chair with seat and back includes dining, table, bar, and lounge models – all stackable, except for 2052 and 2053.

Kevi stools are available with and without castors in 3 heights. Kevi tables are available in Ø90 cm in heights of 72 cm and 36 cm.

Choose from various components – linking bracket, stacking protection, trolley, gliders with feet, chair suspension, armrest, and foot ring.

# Kevi overview

---

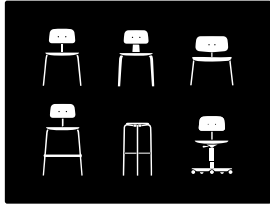

Overview / Kevi Family 158



Office Chair 159



Office Chair - Kids 160

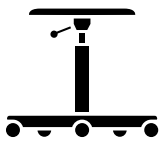

Stool 160

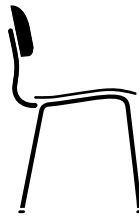

4-leg, Metal 161



4-leg, Wood 161



4-leg, Lounge 161

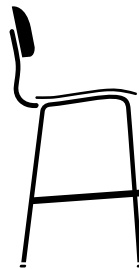

4-leg, Counter 161

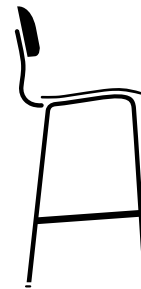

4-leg, Bar 161



4-Leg, Stool 162



Components 163



Surfaces 169

# Kevi Family overview

---

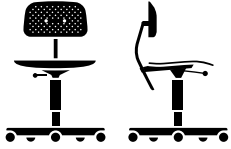

Kevi Air

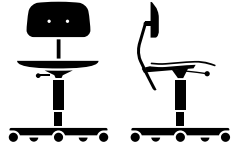

Kevi 2533

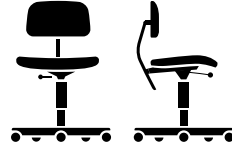

Kevi 2534U

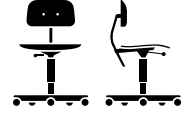

Kevi Kids

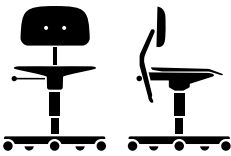

Kevi 2543



Kevi 2532

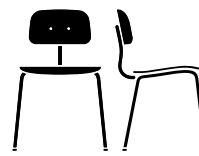

Kevi 2060

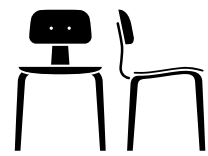

Kevi 2070



Kevi 2063

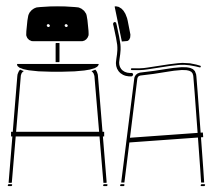

Kevi 2061

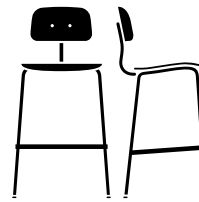

Kevi 2062



Kevi 2051

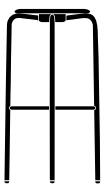

Kevi 2052

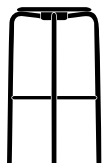

Kevi 2053

# Kevi office chairs

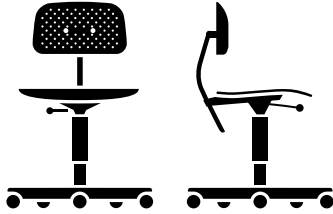

## Kevi Air

SH 38-51 x D 56 x W 56 cm

EAIR & AIRT

### Frame & Material

Office chair with polished 5-star aluminium base or powder-coated, and available with and without tilt. Powder-coated only in height A. Available in 4 heights: Height A 38–51 cm, Height B + 10 cm, Height C + 20 cm, Height D + 30 cm. Braked castors with soft tracking surface (for hard floors) are standard for A and B heights. Height C & D are supplied as standard with gliders, and foot ring is recommended. Seat and back in recycled PP plastic and (removable) seat upholstery as optional.

### Certificates and Test

DIN EN 1729. TÜV Certificate. GS Certificate.

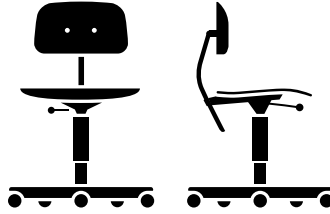

## Kevi 2533

SH 38-51 x D 56 x W 56 cm

E2533 & E2533T

### Frame & Material

Office chair with polished 5-star aluminium base or powder-coated, and available with and without tilt. Powder-coated only in height A. Available in 4 heights: Height A 38–51 cm, Height B + 10 cm, Height C + 20 cm, Height D + 30 cm. Braked castors with soft tracking surface (for hard floors) are standard for A and B heights. Height C & D are supplied as standard with gliders, and foot ring is recommended. Seat and back in moulded veneer. Available as unupholstered, upholstered inner side seat, upholstered inner side seat and back, or fully upholstered. For inner-side upholstery, only Black lazure and veneer can be upholstered.

### Certificates and Test

EU-Ecolabel (Only unupholstered). TÜV Certificate. GS Certificate. DIN EN 1729.

**Seat and back:** PP plastic with powder-coated frame: 95 kg CO<sub>2</sub>e\*, PP plastic with aluminium frame: 90 kg CO<sub>2</sub>e\*, veneer (Lazure): 90 kg CO<sub>2</sub>e\*, upholstered: 190 kg CO<sub>2</sub>e\*.

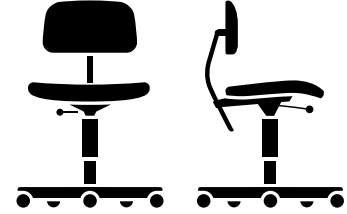

## Kevi 2534U

SH 40-53 x D 56 x W 56 cm

E2534U & 2534UT

### Frame & Material

Office chair with polished 5-star aluminium base or powder-coated, and available with and without tilt. Powder-coated only in Height A. Available in 4 heights: Height A 40–53 cm, Height B + 10 cm, Height C + 20 cm, Height D + 30 cm. Braked castors with soft tracking surface (for hard floors) are standard for A and B heights. Height C & D are supplied as standard with gliders, and foot ring is recommended. Fully upholstered seat and back with 4 cm upholstery.

### Certificates and Test

TÜV Certificate. GS Certificate.

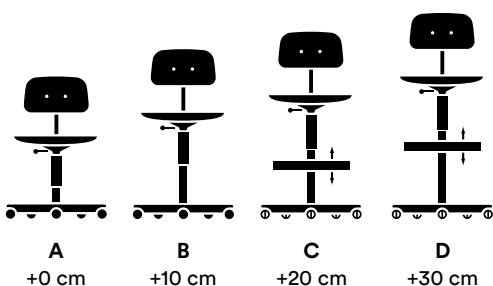

\*Figures vary depending on configuration and upholstery. Calculated by Målbar based on the EU PEF method, cradle-to-grave. Not third-party verified. Further documentation available upon request.

# Kevi office chairs / stool

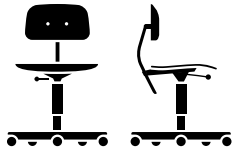

**Kevi Kids** SH 31,5-41,5 x D 46 x W 49 cm

E2533J

### Frame & Material

Swivel chair for kids with 5-star base powder-coated. SH 31.5-41.5 x D 46 x W 49 cm.  
Castors with brakes (soft treads). Seat and back in recycled PP plastic.

### Certificates and Test

EN 1729

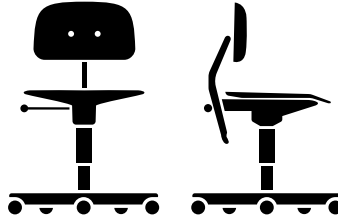

**Kevi 2543** SH 40-53 x D 56 x W 56 cm

E2543

### Frame & Material

Swivel chair with floating tilt and polished 5-star aluminium base.  
Available in 4 heights: Height A 40–53 cm, Height B +10 cm, Height C +20 cm, and Height D +30 cm.  
Double wheel castors with brakes and soft treads are standard on Height A and B models, while glides are standard on Height C and D models. A footring is recommended for the taller C and D versions.  
Seat and backrest are made from compression moulded veneer.

### Certificates and Test

EN 1335-1 type A. EN 1335-2.  
Heights B, C and D doesn't comply with EN 1335



**Kevi 2532** SH 38-51 x D 56 x W 56 cm

E2532

### Frame & Material

Swivel chair with floating tilt and polished 5-star aluminium base.  
Available in 4 heights: Height A 40–53 cm, Height B +10 cm, Height C +20 cm, and Height D +30 cm.  
Double wheel castors with brakes and soft treads are standard on Height A and B models, while glides are standard on Height C and D models. A footring is recommended for the taller C and D versions.  
Seat and backrest are made from compression moulded veneer.

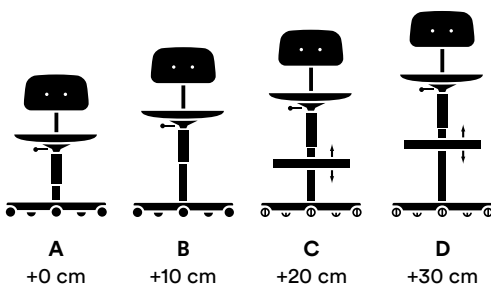

# Kevi 4-legs

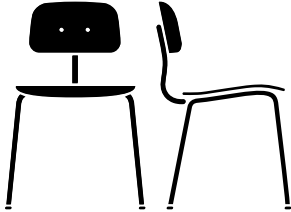

**Kevi 2060** H 79 x SH 47 x D 51 x W 53 cm

E2060

## Frame & Material

18 mm tube in polished chrome or powder-coated finish. Seat and backrest in compression moulded veneer or PP plastic. Available as non-upholstered, upholstered inner seat, fully upholstered seat, upholstered inner seat and back, and fully upholstered. For inner side upholstery, only Black stain and veneer surfaces can be upholstered. Stacking protection should be used when stacking.

## Certificates and Test

EU-Ecolabel (only lazure). EN 16139.

Seat and back; PP Plastic: 39 kg CO<sub>2</sub>e\*,  
Veneer (Lazure): 37 kg CO<sub>2</sub>e\*,  
Upholstered: 140 kg CO<sub>2</sub>e\*.

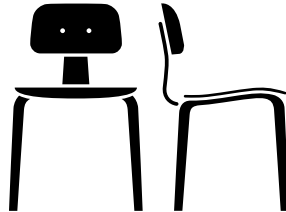

**Kevi 2070** H 79 x SH 47 x D 50 x W 55 cm

E2070

## Frame & Material

Frame, seat and backrest in compression moulded veneer. Available as non-upholstered, upholstered inner seat, or upholstered inner seat and backrest. Inner side upholstery is only possible on Black stain and veneer surfaces.

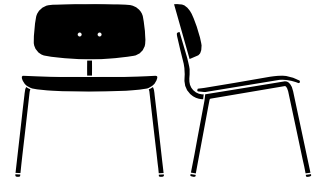

**Kevi 2063** H 73 x SH 43 x D 58,5 x W 64 cm

E2063

## Frame & Material

18 mm tube, polished chrome or powder-coated. Seat and backrest in compression moulded veneer. Available as non-upholstered, upholstered inner seat, fully upholstered seat, upholstered inner seat and backrest, or fully upholstered. Inner side upholstery is only available on Black stain and veneer surfaces.

## Certificates and Test

EN 16139

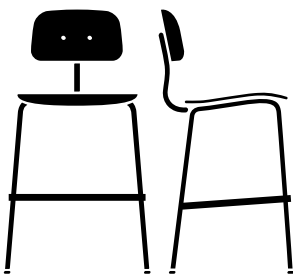

**Kevi 2061** H 98 X SH 66 x D 51 x W 54 cm

E2061

## Frame & Material

18 mm tube, polished chrome or powder-coated. Seat and backrest in compression moulded veneer or recycled PP plastic. Available as non-upholstered, upholstered inner seat, fully upholstered seat, upholstered inner seat and backrest, or fully upholstered. Inner side upholstery is only available on Black stain and veneer surfaces. When stacking, stacking protection should be used.

## Certificates and Test

EN 16139

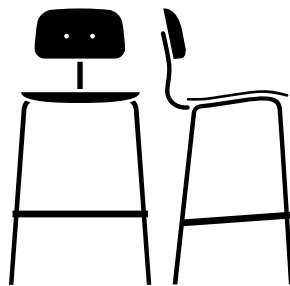

**Kevi 2062** H 108 x SH 76 x D 51 x W 55 cm

E2062

## Frame & Material

18 mm tube, polished chrome or powder-coated. Seat and backrest in compression moulded veneer or recycled PP plastic. Available as non-upholstered, upholstered inner seat, fully upholstered seat, upholstered inner seat and backrest, or fully upholstered. Inner side upholstery is only available on Black stain and veneer surfaces. When stacking, stacking protection should be used.

## Certificates and Test

EN 16139

\*Figures vary depending on configuration and upholstery. Calculated by Målbar based on the EU PEF method, cradle-to-grave. Not third-party verified. Further documentation available upon request.

# Kevi stool / 4-legs

---

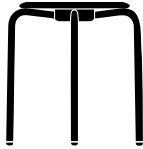

**Kevi 2051**

SH 47 x D 33 x W 33 cm

E2051

**Frame & Material**

18 mm tube, polished chrome or powder-coated.

Round seat in 9 mm compression moulded veneer, non-upholstered.

**Certificates and Test**

EN 16139

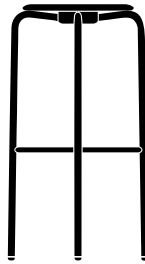

**Kevi 2052**

SH 76 x D 37,5 x W 37,5 cm

E2052

**Frame & Material**

18 mm tube, polished chrome or powder-coated.

Round seat in 9 mm compression moulded veneer, non-upholstered.

Stackable during transport.

Footrest to be assembled on site by the end-user using an Allen key.

**Certificates and Test**

EN 16139

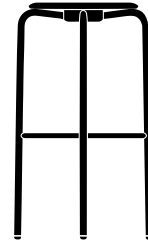

**Kevi 2053**

SH 66 x D 37,5 x W 37,5 cm

E2053

**Frame & Material**

18 mm tube, polished chrome or powder-coated.

Round seat in 9 mm compression moulded veneer, non-upholstered.

Stackable during transport.

Footrest to be assembled on site by the end-user using an Allen key.

**Certificates and Test**

EN 16139

# Kevi components — office chairs

---

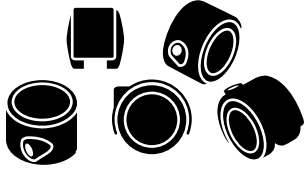

## Double Wheel Castors

with Brakes and Soft Treads

**CC01**

**Model** Standard for A & B heights  
**Material** Black plastic.

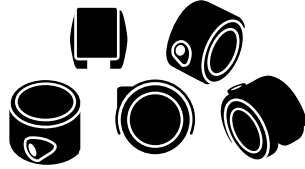

## Double Wheel Castors

without Brakes and Soft Treads

**CC03**

**Model** For A & B heights  
**Material** Black plastic.

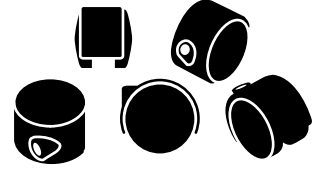

## Double Wheel Castors

with Brakes and Hard Treads

**CC02**

**Model** For A & B heights  
**Material** Black plastic.

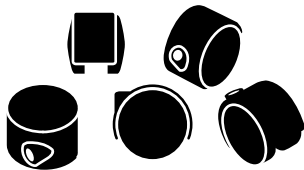

## Double Wheel Castors

with Brakes and Hard Treads

**CC04**

**Model** For A & B heights  
**Material** Black plastic.

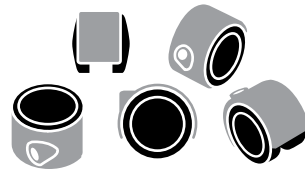

## Double Wheel Castors

with alu caps without brakes

**CC05**

**Model** For A & B heights  
**Material** Black plastic with handpolished aluminium caps.



## Gliders

Standard for C & D height

**CC06**

**Model** Standard for C & D heights  
**Material** Black plastic.

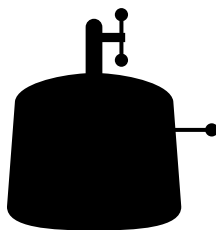

## Seat Carrier with Tilt

For Kevi chairs

**KESB4**

**Model** All  
**Material** Black

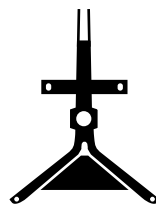

## Seat Carrier

For Kevi stools / chairs

**KESB1**

**KESB2** 1 pcs for stool  
**Model** 1 pcs for chair  
**Material** All  
Black powder-coated.

# Kevi components — office chairs

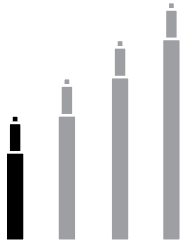

## Gas Cartridge

Standard A height

<b>KER5:</b>	Polished aluminium or powder-coated
<b>Model</b>	All
<b>Material</b>	Aluminium

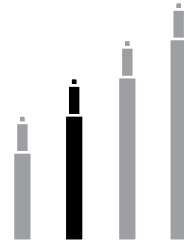

## Gas Cartridge

B-height

<b>KER6</b>	All
<b>Model</b>	All
<b>Material</b>	Polished aluminium

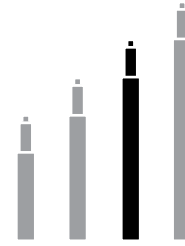

## Gas Cartridge

C-height

<b>KER7</b>	All
<b>Model</b>	All
<b>Material</b>	Polished aluminium

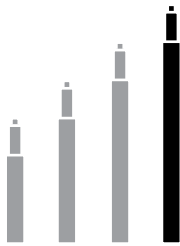

## Gas Cartridge

D-height

<b>KER8</b>	All
<b>Model</b>	All
<b>Material</b>	Polished aluminium

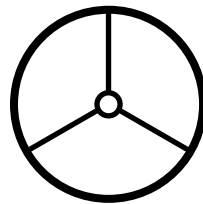

## Foot Ring

Recommended for C & D height Kevi chairs

<b>KFODRING</b>	All
<b>Model</b>	All
<b>Material</b>	Polished aluminium

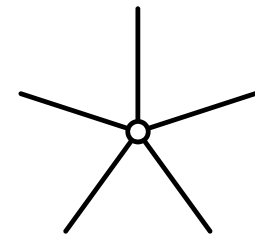

## 5-Star Foot Cross

<b>KER18:</b>	Polished aluminium or powder-coated
<b>Model</b>	All
<b>Material</b>	Aluminium



## Kevi Tool

For Kevi office chair

<b>KER14</b>	All
<b>Model</b>	All
<b>Material</b>	Metal

# Kevi components — office chairs

---

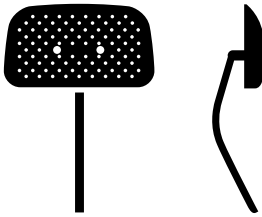

## Kevi Air Backrest

Backrest (incl. bracket)

**KER1**  
Material Recycled PP

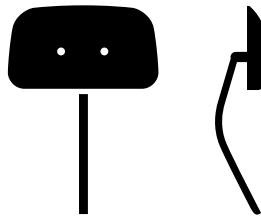

## Kevi 2533 Backrest

Backrest (incl. bracket)

**KER2**  
Material Lazure or oak

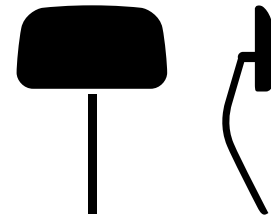

## Kevi 2533 Backrest

Backrest (incl. bracket and upholstered inner side)

**KER2**  
Material Full upholstery in fabric or leather

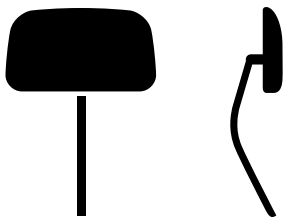

## Kevi 2534U Backrest

Backrest (incl. bracket)

**KER3**  
Material Full upholstery in fabric or leather

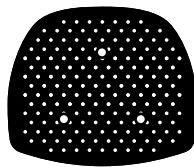

## Kevi Air Seat

Seat (excl. seat carrier)

**KESE1**  
Material Recycled PP

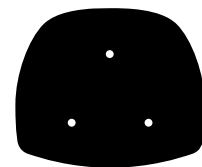

## Kevi 2533 Seat

Seat (excl. seat carrier)

**KESE2**  
Material Lazure or oak

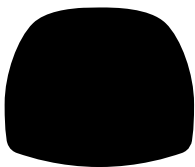

## Kevi 2533 Seat

Seat (excl. seat carrier, incl. upholstered inner side)

**KESE2**  
Material Full upholstery in fabric or leather

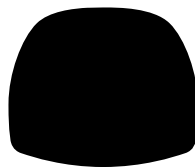

## Kevi 2534U Seat

Seat (excl. seat carrier)

**KESE3**  
Material Full upholstery in fabric or leather

# Kevi components — office chairs

---



## Kevi Armrest

**KER20**

**Material** Black integral foam, polished aluminium.

**Note:** Available for models produced after January 2019. After this, a new seat carrier must also be purchased.

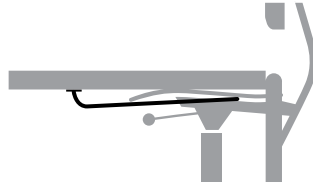

## Chair Suspension

For table widths above 70 cm

**OPKE1**

**Model** All except 2532, 2534U and fully upholstered 2533

**Material** Steel, polished chrome.

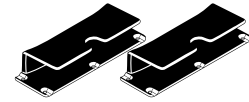

## Chair Suspension

**OPKE**

**Model** All except 2532, 2534U and fully upholstered 2533

**Material** Black plastic

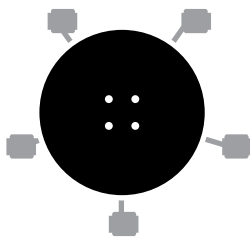

## Kevi 2532 Seat

Seat (excl. seat carrier)

**KESE5**

**Material** All lazure colours and Oak veneer



## Loose Back Brace

incl. screws

**KER23**

**Material** Polished aluminium

# Kevi linking brackets — 4 legs

---

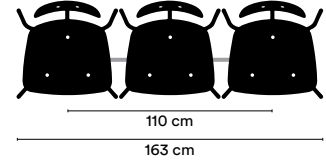
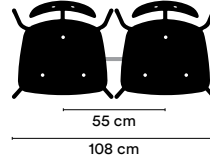
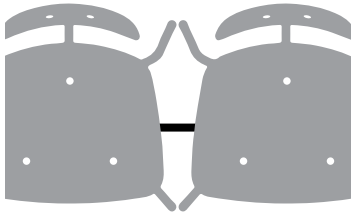

## Linking Device 201

## Kevi 2060 with Linking Device E201

<b>KER11</b>	
<b>Model</b>	Kevi 2060.
<b>Min order</b>	None.
<b>Material</b>	Polished chrome.

# Kevi components — 4 legs

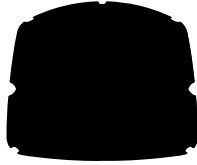

## Stacking Shield 202

**KER34 Model** Kevi 2060, 2061, 2062  
Recommended for all chairs with and without coupling fittings.

**Min order** None.

**Material** Black plastic.

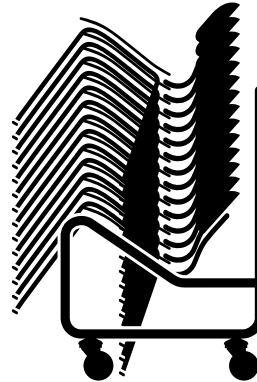

## Trolley 2090

**KE2090 Model** Kevi 2060, 2070.

**Dimensions** H 109\* x W 42 x D 75,5 cm.

**Quantity** 20/16 Kevi chairs (unupholstered/ upholstered) or 10 Kevi 2070.

**Material** Powder-coated black with 4 adjustable wheels.

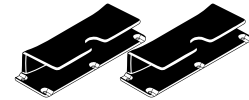

## Chair Suspension

**OPKE Model** All except stools and fully upholstered 2060

**Material** Black plastic.

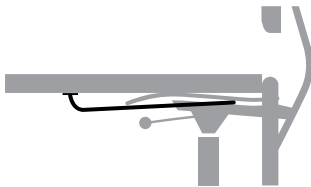

## Chair Suspension

For table widths above 70 cm w. double chair suspension

**OPKE1 Model** All, except 2051, 2052, 2053.

**Material** Steel, polished chrome.



## Glides without Felt

**KER24 - Set of 4. Model** Kevi glides without felt, steel frame.

**KER25 - Set of 4. Model** Kevi glides without felt, wooden frame.



## Glides with Felt

**KEFILT - Set of 4. Model** Kevi glides with felt, steel frame.

**KER13 - Set of 4. Model** Kevi glides with felt, wooden frame.

# Kevi surfaces — shell

## Materials

Kevi is available with hard surfaces in veneer, lazure (stained ash), and plastic.

The shells for Kevi Air and Kevi Kids are made from 100% recycled PP plastic and feature a textured, uniform surface.

Page 171 features the price groups and colour examples of fabrics and leathers for the upholstered variants.

### Veneer (Lacquered)

Kevi 2532, 2533, 2543  
All on 4 legs



Veneer Oak 300

### Recycled PP

Kevi Air, 2060, 2061,  
2062

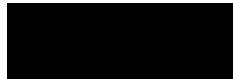

PP Black 05A



PP Snow 38A



PP Juniper 138A



PP Oregano 139A



PP Camomille 159A

### Recycled PP

Kevi 2533J



PP Amber 142P



PP Flint 148P



PP Rhubarb 151P



PP Parsley 152P

### Lazure/Stained Wood

Kevi 2532, 2533, 2543\*,  
2051, 2052, 2053, 2060,  
2061, 2062, 2063, 2067,  
2068, 2070\*



Lazure Black 05

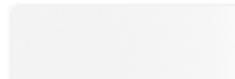

Lazure Snow 38



Lazure Oyster 156



Lazure Rhubarb 151



Lazure Hokkaido 162



Lazure Azure 154



Lazure Pine 136



Lazure Shadow 147

\* Only in Black 05.

Please note that printed colours may differ from the original colour.

# Kevi surfaces — frame

## Materials

Powder-coated frame is available only as an optional extra for height A and for the mentioned models. Kevi is available with surfaces in lasur, lacquered veneer, and recycled polypropylene. Kevi Air and Kevi Kids are made from 100% recycled PP plastic and feature a textured, uniform surface. Page 171 features the price groups and colour examples of fabrics and leathers for the upholstered variants.

### Frame Colours

Kevi Air\*\*, 2533, 2534U, 2532, 2051, 2052, 2053, 2060, 2061, 2062, 2063, 2067, 2068, 2070\*



Powder Coat Black 05

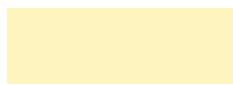

Powder Coat Camomille 159



Aluminium 45P



Chrome Chrome 44C



PP Amber 142P

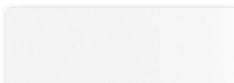

Powder Coat Snow 38



Powder Coat Oregano 139



PP Flint 148P



Powder Coat Oyster 156



Powder Coat Juniper 138



PP Rhubarb 151P



Powder Coat Rhubarb 151



PP Parsley 152P



Powder Coat Hokkaido 162



Powder Coat Azure 154



Powder Coat Pine 136



Powder Coat Shadow 147

\*Only in Black 05. \*\*Only in Black 05, Snow 38, Juniper 138, Oregano 139, Camomille 159.

Please note that printed colours may differ from the original colour.



# Kevi upholstery

---

## Shells with Upholstery

Inner side upholstery is only available on shells in Black lazur and veneer.

## Fabric

The upholstered Kevi models are available with ordinary upholstery or the exclusive full upholstery, in which both the edge of the seat and the backside of the backrest is upholstered in the chosen material. Montana Furniture offers a wide range of fabrics from quality conscious suppliers, such as Kvadrat and Gabriel.

## Leather

Montana Furniture offer leather upholstery from quality suppliers such as Sørensen Leather and Nevotex.

Pigmented leather (i.e. Ultra): Corrected leather that has been given a surface treatment. The leather is very durable and easy to maintain. Resists stains and provides a homogeneous look.

Aniline leather (i.e. Elegance and Copenhagen): Made from the best raw hides. The natural surface has been preserved untreated for optimal comfort. Daily use gives the leather its own unique character and personality.

**To see the full colour range:** Visit the suppliers' own websites or drop by Montana Furniture's showroom or dealers.

Requesting other colors than the standard colors on leather is possible when using whole hides.

### Price Group 1

---

**FABRIC**  
STAMSKIN TOP  
XTREME\*  
VALENCIA  
REMIX\*  
CYBER\*  
RENEWED LOOP\*

### Price Group 2

---

**FABRIC**  
FAME\*  
RE-WOOL\*  
RAAS\*  
SABI\*  
MADS NØRGAARD

### Price Group 3

---

**FABRIC**  
TONUS\*  
STEELCUT\*  
STEELCUT TRIO\*  
HALLINGDAL\*  
UMBER\*

### Price Group 4

---

**LEATHER**  
ULTRA (Black: 41599, Brandy: 41574)  
SIERRA (Black: 1001, Cognac: 1003, Grey: 1007,  
Calvados: 1070, Stone: 1611)  
ORGANIC (Black)  
DAKAR (Cognac, Black)

### Price Group 5

---

**LEATHER**  
COPENHAGEN (Black: 1100450, Cognac: 1100451)  
SAVANNE

### Price Group 6

---

**LEATHER**  
ELEGANCE (Black: 20198)



\*All textiles with a star are EU Ecolabel certified.

**Note:** The price groups according to fabric, leather or material qualities are aligned with each product line. Hence, the content of these price groups may vary.



# Chairik

18 models / Design: Erik Magnussen



## Functional and Space-Saving Chair Series

Chairik is a flexible and space-saving chair series with a minimalist and modern design that combines functionality and comfort. The chair is available as a shell chair in recycled polypropylene or with various upholstery options and can be chosen in several sizes and heights.

### Technical Information

Chairik has an extraordinary stacking capacity of up to 45 chairs on a trolley, making it ideal for environments where space optimisation is important. The series offers different frames, including four-legged, sled base, and 5-star swivel base, and can be customised with armrests as needed. The series also includes practical accessories such as stacking and transport trolleys for easy handling and storage. With its simple and timeless design, Chairik is suitable for private homes, workplaces, and public institutions where flexibility and functionality are the focus.

# Chairik overview

---

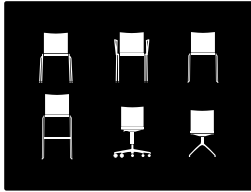

Overview / Chairik Family 174



4-legs 175



Sled 176



Starbase 177



Components 178

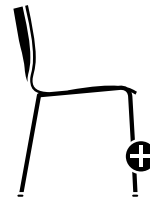

Options & Features 184



Surfaces 185

# Chairik Family overview

---

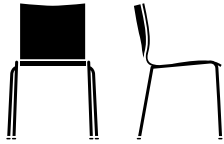

Chairik 101

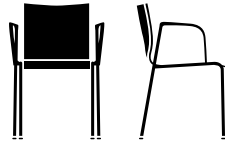

Chairik 109

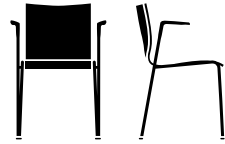

Chairik 113

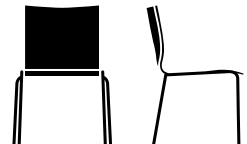

Chairik 121 XL

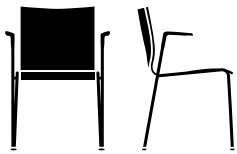

Chairik 123 XL

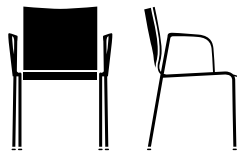

Chairik 129 XL

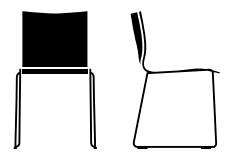

Chairik 107

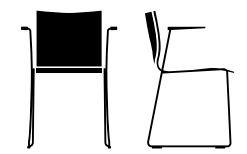

Chairik 111

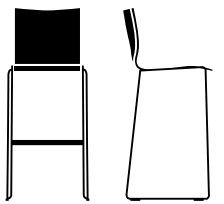

Chairik 117

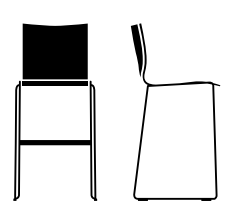

Chairik 119

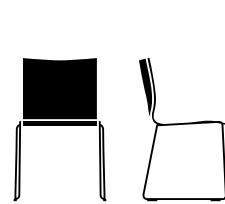

Chairik 127 XL

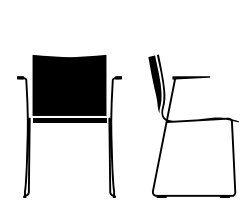

Chairik 128 XL



Chairik 134 XL



Chairik 135 XL



Chairik 136 XL

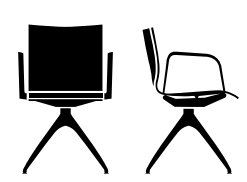

Chairik 137 XL



Chairik 148 XL



Chairik 149 XL

# Chairik 4 legs

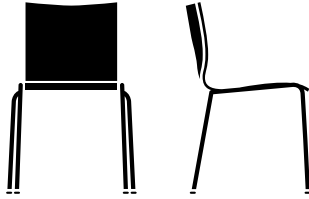

**Chairik 101** H 75 x SH 45 x D 54 x W 50 cm

CH101

## Frame & Material

Frame in 16 mm tube, chrome-plated or powder-coated. Available in thermoformed melamine, melamine veneer, or recycled PP plastic. Available as unupholstered, upholstered seat interior, upholstered seat and back interior, and fully upholstered. Stacking protection should be used when stacking; this is automatically included with the fully upholstered chair.

Optional: Preparation for on/off seat upholstery.

## Certificates and Test

EU- Ecolable (only Melamine)  
EN 16139

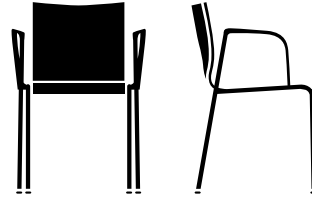

**Chairik 109** H 75 x SH 45 x D 54 x W 52 cm

CH109

## Frame & Material

Frame in 16 mm tube, chrome-plated with polished aluminium armrests. Available in thermoformed melamine, melamine veneer, or recycled PP plastic. Available as unupholstered, upholstered seat interior, upholstered seat and back interior, and fully upholstered. Stacking protection should be used when stacking; this is automatically included with the fully upholstered chair.

Optional: Preparation for on/off seat upholstery.

## Certificates and Test

EN 16139

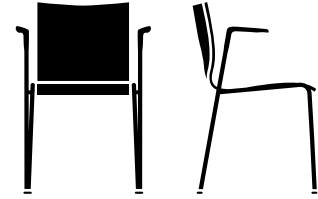

**Chairik 113** H 75 x SH 45 x D 54 x W 52 cm

CH113

## Frame & Material

16 mm tube frame in polished chrome with polished aluminium armrests. Seat shell in compression moulded melamine, melamine veneer or recycled polypropylene. Available in non-upholstered, upholstered inner side seat, upholstered inner side seat and back, or fully upholstered versions. Stacking protection should be used when stacking and is included by default with fully upholstered chairs.

Optional: Preparation for on-/off seat upholstery.

## Certificates and Test

EN 16139

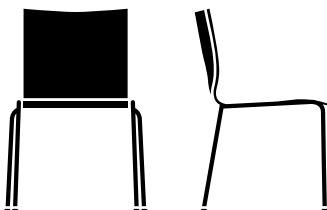

**Chairik 121 XL** H 79 x SH 46 x D 58 x W 55 cm

CH121XL

## Frame & Material

18 mm tube frame in polished chrome or powder-coated finish. Seat shell in compression moulded melamine, melamine veneer, or polypropylene (Snow and Black) with a rippled surface. Available in non-upholstered, upholstered inner side seat, upholstered inner side seat and back, or fully upholstered versions. Stacking protection should be used when stacking and is included by default with fully upholstered chairs.

Optional: Preparation for on-/off seat upholstery.

## Certificates and Test

EN 16139

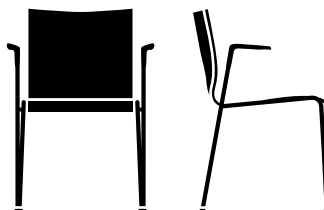

**Chairik 123 XL** H 79 x SH 46 x D 58 x W 57 cm

CH123XL

## Frame & Material

18 mm tube frame in polished chrome with polished aluminium armrests. Seat shell in compression moulded melamine, melamine veneer, or polypropylene (Snow and Black) with a rippled surface. Available in non-upholstered, upholstered inner side seat, upholstered inner side seat and back, or fully upholstered versions. Stacking protection should be used when stacking and is included by default with fully upholstered chairs.

Optional: Preparation for on-/off seat upholstery.

## Certificates and Test

EN 16139

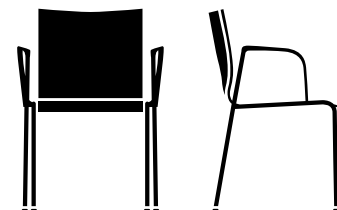

**Chairik 129 XL** H 79 x SH 46 x D 58 x W 57 cm

CH129XL

## Frame & Material

16 mm tube frame in polished chrome with polished aluminium armrests. Seat shell in compression moulded melamine, melamine veneer or recycled polypropylene. Available as non-upholstered, upholstered inner side seat, upholstered inner side seat and back, or fully upholstered. Stacking protection should be used when stacking and is included as standard with fully upholstered chairs.

Optional: Preparation for on-/off seat upholstery.

## Certificates and Test

EN 16139

# Chairik sled base

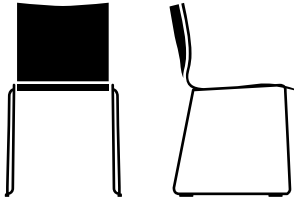

**Chairik 107** H 77 x SH 46 x D 53 x W 47 cm

CH107

## Frame & Material

11 mm wire frame in chrome or powder-coated finish. Seat shell in compression moulded melamine, melamine veneer, or recycled polypropylene. Available as non-upholstered, upholstered inner side seat, upholstered inner side seat and back, or fully upholstered. Stacking protection should be used when stacking and is included as standard with fully upholstered chairs. Optional: Preparation for on-/off seat upholstery.

## Certificates and Test

EU- Ecolable (only Melamine).  
EN 16139

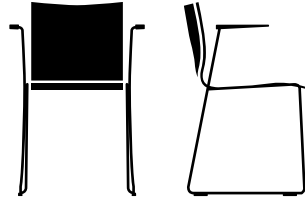

**Chairik 111** H 77 x SH 46 x D 53 x W 52 cm

CH111

## Frame & Material

11 mm wire frame in chrome with polished aluminium armrests. Seat shell in compression moulded melamine, melamine veneer, or recycled polypropylene. Available as non-upholstered, upholstered inner side seat, upholstered inner side seat and back, or fully upholstered. Stacking protection should be used when stacking and is included as standard with fully upholstered chairs. Optional: Preparation for on-/off seat upholstery.

## Certificates and Test

EN 16139

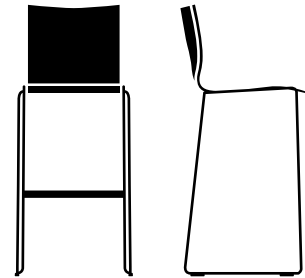

**Chairik 117** H 107 x SH 76 x D 53 x W 47 cm

CH117

## Frame & Material

11 mm wire frame in chrome or powder-coated finish. Seat shell in compression moulded melamine, melamine veneer, or recycled polypropylene. Available as non-upholstered, upholstered inner side seat, upholstered inner side seat and back, or fully upholstered. Stacking protection should be used when stacking and is included as standard with fully upholstered chairs. Optional: Preparation for on-/off seat upholstery.

## Certificates and Test

EN 16139

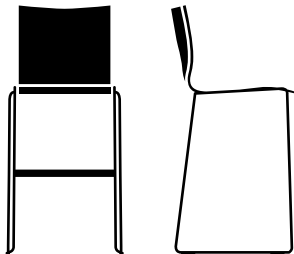

**Chairik 119** H 98 x SH 68 x D 52 x W 47 cm

CH119

## Frame & Material

11 mm wire frame in chrome or powder-coated finish. Seat shell in compression moulded melamine, melamine veneer or recycled polypropylene. Available as non-upholstered, upholstered inner side seat, upholstered inner side seat and back, or fully upholstered. Stacking protection should be used when stacking and is included as standard with fully upholstered chairs. Optional: Preparation for on-/off seat upholstery.

## Certificates and Test

EN 16139

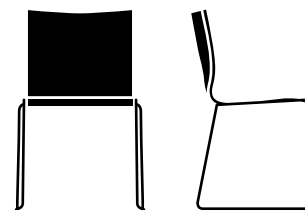

**Chairik 127 XL** H 80 x SH 46 x D 57 x W 52 cm

CH127XL

## Frame & Material

11 mm wire frame in chrome or powder-coated finish. Seat shell in compression moulded melamine, melamine veneer or polypropylene (Snow and Black) with a rippled surface. Available as non-upholstered, upholstered inner side seat, upholstered inner side seat and back, or fully upholstered. Stacking protection should be used when stacking and is included as standard with fully upholstered chairs. Optional: Preparation for on-/off seat upholstery.

## Certificates and Test

EN 16139

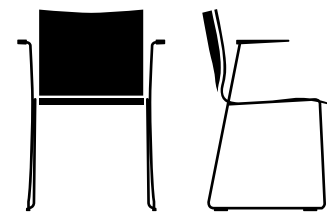

**Chairik 128 XL** H 80 x SH 46 x D 57 x W 57 cm

CH128XL

## Frame & Material

11 mm wire frame in chrome with polished aluminium armrests. Seat shell in compression moulded melamine, melamine veneer, or polypropylene (Snow and Black) with a rippled surface. Available as non-upholstered, upholstered inner side seat, upholstered inner side seat and back, or fully upholstered. Stacking protection should be used when stacking and is included as standard with fully upholstered chairs. Optional: Preparation for on-/off seat upholstery.

## Certificates and Test

EN 16139

# Chairik starbase



5-star

## Chairik 134 XL

H 80-93 x SH 43-56 x  
D 73 x W 73 cm

CH134XL

### Frame & Material

Aluminium frame with braked castors (soft treads).

Seat shell in compression moulded melamine, melamine veneer, or polypropylene (Snow and Black) with a rippled surface. Available as non-upholstered, upholstered inner side seat, upholstered inner side seat and back, or fully upholstered.

### Certificates and Test

EN 16139

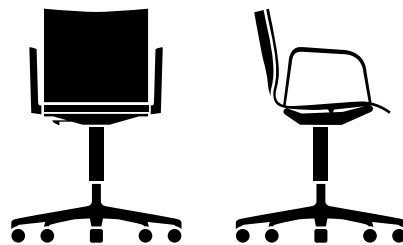

5-star

## Chairik 135 XL

H 80-93 x SH 43-56 x  
D 73 x W 73 cm

CH135XL

### Frame & Material

Aluminium frame with polished armrests and braked castors (soft treads).

Seat shell in compression moulded melamine, melamine veneer, or polypropylene (Snow and Black) with a textured surface. Available as non-upholstered, upholstered inner side seat, upholstered inner side seat and back, or fully upholstered.

### Certificates and Test

EN 16139

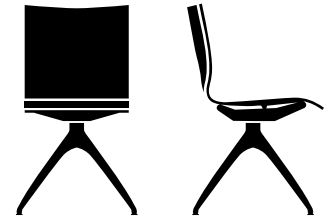

4-star

## Chairik 136 XL

H 84 x SH 47 x D 53 x W 49 cm

CH136XL

### Frame & Material

Aluminium frame.

Seat shell in compression moulded melamine, melamine veneer, or polypropylene (Snow and Black) with a textured surface.

Available as non-upholstered, upholstered inner side seat, upholstered inner side seat and back, or fully upholstered.

### Certificates and Test

EN 16139

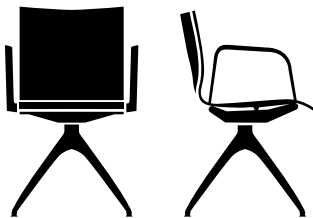

4-star

## Chairik 137 XL

H 84 x SH 47 x D 53 x W 53 cm

CH137XL

### Frame & Material

Aluminium frame with polished aluminium armrests.

Seat shell in compression moulded melamine, melamine veneer, or polypropylene (Snow and Black) with a textured surface. Available as non-upholstered, upholstered inner side seat, upholstered inner side seat and back, or fully upholstered.



5-star

## Chairik 148 XL

H 80-92 x SH 44-55 x D 62.5 x  
W 41 cm. (Base Ø70 cm)

CH148XL

### Frame & Material

Black frame with base in recycled plastic and braked castors (soft treads).

Seat shell in compression moulded melamine, melamine veneer, or polypropylene (Snow and Black) with a textured surface. Available as non-upholstered, upholstered inner side seat, upholstered inner side seat and back, or fully upholstered.



5-star

## Chairik 149 XL

H 80-92 x SH 44-55 x D 62.5 x  
W 41 cm. (Base Ø70 cm)

CH149XL

### Frame & Material

Black frame with base in recycled plastic, black lacquered aluminium armrests, and braked castors (soft treads).

Seat shell in compression moulded melamine, melamine veneer, or polypropylene (Snow and Black) with a textured surface.

Available as non-upholstered, upholstered inner side seat, upholstered inner side seat and back, or fully upholstered.

# Chairik components

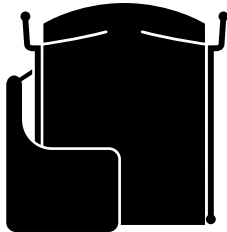

## Writing Tablet 173

For Chairik with 4-legged base

<b>CH173</b>	
<b>Model</b>	101, 113
<b>Dimensions</b>	45 × 30 cm
<b>Material</b>	White or black laminated tabletop with a chrome-plated steel frame.

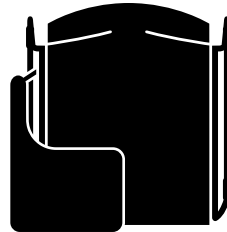

## Writing Tablet 174

For Chairik with sled base.

<b>CH174</b>	
<b>Model</b>	107, 111
<b>Dimensions</b>	45 × 30 cm
<b>Material</b>	White or black laminated tabletop with a chrome-plated steel frame.

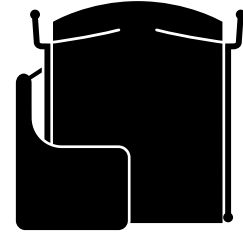

## Writing Tablet 178

Chairik XL with 4-legged base

<b>CH178</b>	
<b>Model</b>	121XL, 123XL
<b>Dimensions</b>	45 × 30 cm
<b>Material</b>	White or black laminated tabletop with a chrome-plated steel frame.



## Writing Tablet 179

Chairik XL with sled base.

<b>CH179</b>	
<b>Model</b>	127XL, 128XL
<b>Dimensions</b>	45 × 30 cm
<b>Material</b>	White or black laminated tabletop with a chrome-plated steel frame.

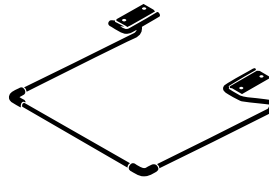

## Chair Suspension 185

4-legged base and sled base

<b>CH185</b>	
<b>Model</b>	101, 107, 109, 111, 113, 121XL, 123XL, 129XL, 127XL, 128XL
<b>Dimensions</b>	35 × 7 × 34 cm
<b>Material</b>	Steel.

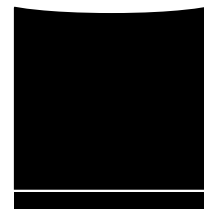

## Chairik / Chairik XL

Loose PP/plastic shell

<b>CHR10</b> (Chairik)	
<b>CHR11</b> (Chairik XL)	
<b>Model</b>	All

## On/Off seat Chairik/Chairik XL

Magnetic seat in Melamine incl. magnets

<b>CHL15</b> (Chairik)	
<b>CHL16</b> (Chairik XL)	
<b>Model</b>	All

Magnetic seat in PP Melamine incl. magnets

<b>CHL19</b> (Chairik)	
<b>CHL20</b> (Chairik XL)	
<b>Model</b>	All

# Chairik components

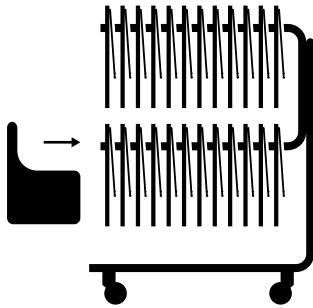

## Writing Tablet Trolley 177

all writing pads

### CH177

**Model** 173, 174, 178XL, 179XL  
**Dimensions** W: 100 x H: 152 x D: 110 cm  
**Quantity** 60 writing pads.  
**Material** Powder-coated black.



## Stacking Protection Chairik/Chairik XL

### CHR12 (Chairik)

### CHR13 (Chairik XL)

**Model** All stacking chairs  
**Material** Black felt  
 Stacking protection should be used when stacking, this is automatically included with the fully upholstered chair.



## Trolley 184

### CH184

**Model** All sled & 4-legged bases  
**Dimensions** W: 63 x H: 112\* x D: 63 cm  
**Quantity** 10-20 unupholstered chairs with sled base or 15 unupholstered chairs with 4-legged base.  
**Material** Powder-coated black with two fixed castors.



## Trolley 165

### CH165

**Model** Model All sled & 4-legged bases  
**Dimensions** H: 152\* x W: 70 x D: 96 cm  
**Quantity** 12-20 upholstered chairs.  
**Material** Powder-coated black with two fixed and two swivel castors.

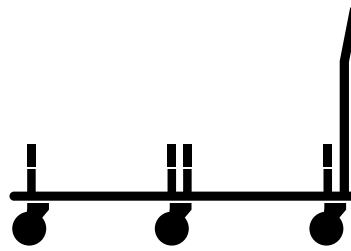

## Trolley Cart 176

### CH176

**Model** Model for sled base 107, 111, 127XL, 128XL  
**Dimensions** H: 113\* x W: 76 x D: 140 cm  
**Quantity** 90 upholstered chairs.  
**Material** Powder-coated black with two fixed and four swivel castors.

\*Height of the trolley is without chairs.  
 The total height depends on the model and quantity.

# Chairik components

---

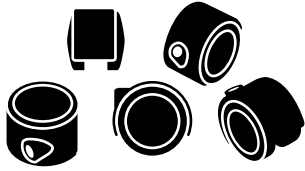

## Double Wheel Castors

with Brakes and Soft Treads

**CC01**  
**Model** 134XL, 135XL, 148XL, 149XL  
**Material** Plastic, black

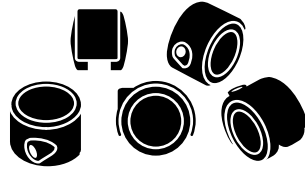

## Double Wheel Castors

without Brakes and Soft Treads

**CC03**  
**Model** 134XL, 135XL, 148XL, 149XL  
**Material** Plastic, black

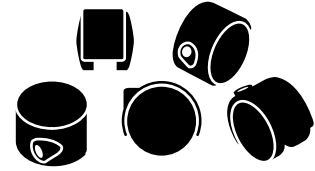

## Double Wheel Castors

with Brakes and Hard Treads

**CC02**  
**Model** 134XL, 135XL, 148XL, 149XL  
**Material** Plastic, black

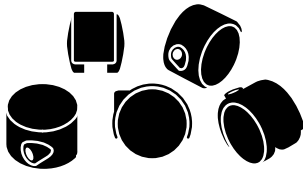

## Double Wheel Castors

with Brakes and Hard Treads

**CC04**  
**Model** 134XL, 135XL, 148XL, 149XL  
**Material** Plastic, black

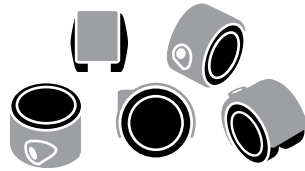

## Double Wheel Castors

with alu caps without brakes

**CC05**  
**Model** 134XL, 135XL, 148XL, 149XL  
**Material** Plastic, black, with hand-polished aluminium caps.

# Chairik components

---



## Glides

Chairik & Chairik XL for sled base.

---

CHR1 - 4 pieces



## Glides with Felt

Chairik & Chairik XL for sled base

---

CHR2 - 4 pieces



## Glides with Stacking Guide & Felt

Chairik & Chairik XL for sled base

---

CHR3 - 4 pieces



## Glides without Felt

Chairik for 4-legged base.

---

CHR6 - 4 pieces



## Glides with Felt

Chairik for 4-legged base

---

CHR7 - 4 pieces



## Glides without Felt

Chairik XL for 4-legged base.

---

CHR4 - 4 pieces



## Glides with Felt

Chairik XL for 4-legged base.

---

CHR5 - 4 pieces

# Chairik components

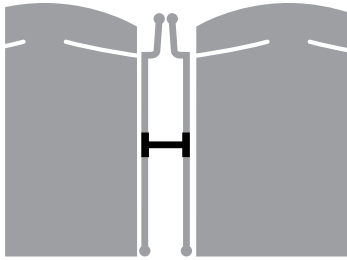

## Linking Bracket 180

Chairik with 4-legged base

**CH180**

**Model** 101, 109, 113

**Dimensions** 16 x 7 cm

**Material** Steel, chrome-plated.

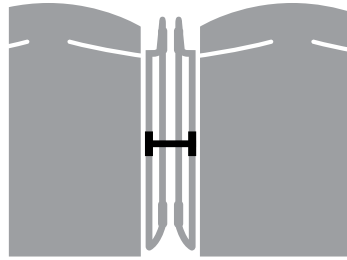

## Linking Bracket 192

Chairik with sled base

**CH192**

**Model** 107, 111, 127, 128XL

**Dimensions** 16 x 7 cm

**Material** Steel, chrome-plated.

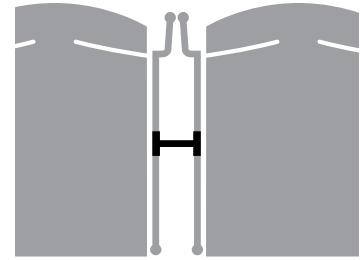

## Linking Bracket 194

Chairik XL with 4-legged base

**CH194**

**Model** 121XL, 123XL, 129XL

**Dimensions** 17.5 x 7 cm

**Material** Steel, chrome-plated.

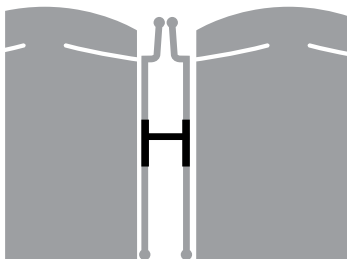

## Linking Bracket 181

Chairik with 4-legged base & writing tablet

**CH181**

**Model** 101, 109, 113

**Dimensions** 16 x 10 cm

**Material** Steel, chrome-plated.

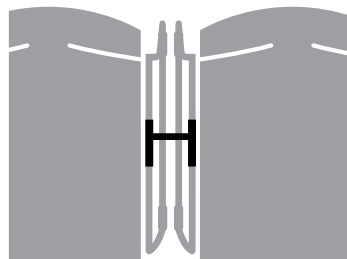

## Linking Bracket 193

Chairik with sled base & writing tablet

**CH193**

**Model** 107, 111, 127XL, 128XL

**Dimensions** 16 x 10 cm

**Material** Steel, chrome-plated.

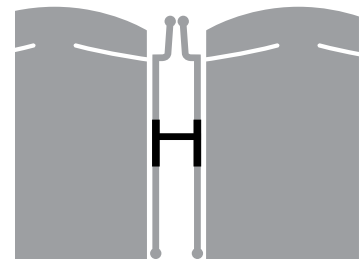

## Linking Bracket 195

Chairik XL with 4-legged base & writing tablet

**CH195**

**Model** 121XL, 123XL, 129XL

**Dimensions** 16 x 10 cm

**Material** Steel, chrome-plated.

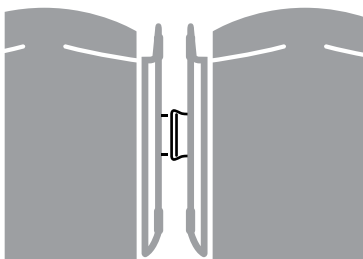

## Linking Bracket 199

Chairik with sled base

**CH199**

**Model** 107, 111, 127XL, 128XL

**Note** Fixed-mounted

**Material** Steel, chrome-plated.

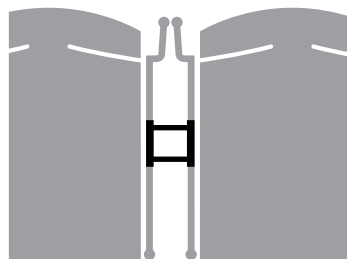

## Linking Bracket 161\*

Chairik sled base & 4-legged base

**CH161**

**Model** Available on request

**Dimensions** 16 x 16 cm

**Material** Steel, chrome-plated.

# Chairik setups / examples

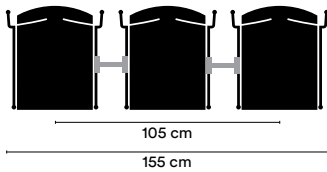
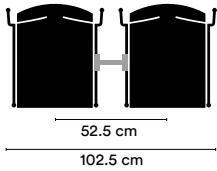
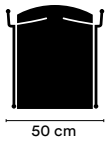

**Chairik 101**  
with linking brackets CH180 & CH181

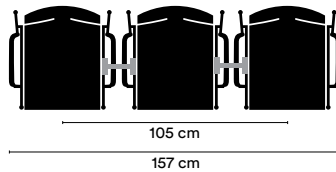
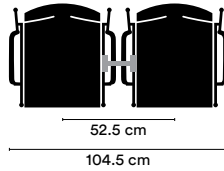
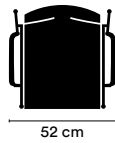

**Chairik 109 & 113**  
with linking brackets CH180 & CH181

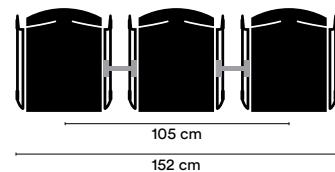
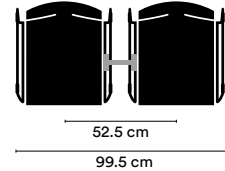

**Chairik 107**  
with linking brackets CH192, CH193 & CH199\*

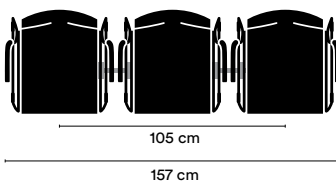
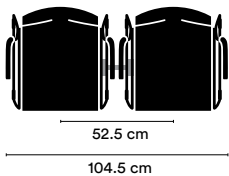
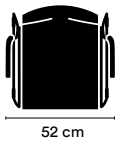

**Chairik 111**  
with linking brackets CH192, CH193 & CH199\*

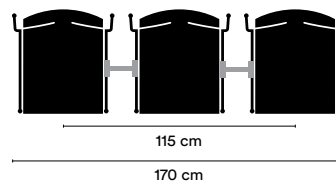
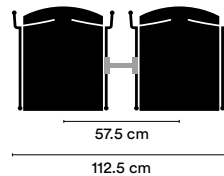
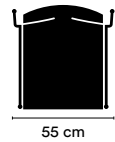

**Chairik 121XL**  
with linking brackets CH194 & CH195

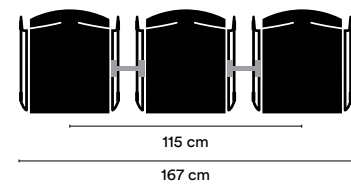
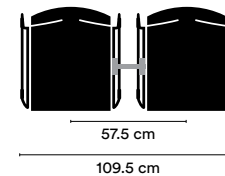

**Chairik 127XL**  
with linking brackets CH192, CH193 & CH199\*

\* The last chair on a row will be 4 cm wider on the right and 4.7 cm wider on the left than a standard Chairik.

# Chairik extra features



## On/off Upholstered Seat

By pre-installing magnets under the chair shell, it is possible to change the appearance of the Chairik and add extra comfort with a removable upholstered seat. Customise the chair to suit the situation and select the colour and finish to match your mood.

<b>Fits models</b>	All models
<b>Minimum order</b>	No
<b>Setup fee</b>	No
<b>Additional cost</b>	Yes



## Lacquered Bases in Custom Colours

If the Chairik needs to match a specific design or interior theme, it is possible to customise a selection of our bases and lacquer them in any RAL or NCS colours, ensuring that the base and chair complement each other and the room.

<b>Fits models</b>	4-leg & sled base
<b>Minimum order</b>	100 units
<b>Setup fee</b>	Yes
<b>Additional cost</b>	Upon request



## Chairs for Outdoor Use

Selected Chairik models and materials are suitable for outdoor use. The combination of plastic with a water-repellent lacquered base creates a durable chair for outdoor environments.

<b>Fits models</b>	4-leg & sled base (without armrests)
<b>Minimum order</b>	50 units
<b>Setup fee</b>	Yes
<b>Additional cost</b>	Yes



## Unique Design in Melamine

Montana Furniture offers unique design chairs with a durable melamine surface. Your personal design or Pantone colour will be printed on paper and fixed under the melamine surface. It is possible to create unique designs on both the front and back of the chair.

<b>Fits models</b>	All
<b>Minimum order</b>	No
<b>Setup fee</b>	Yes
<b>Additional cost</b>	Per side, yes



## Customer's Own Fabric or Leather

It is possible to use your own fabric or leather to create a completely unique upholstered Chairik with lots of personality. We always send a fabric or leather sample to the supplier to ensure that the quality matches the specific chair model.

<b>Fits models</b>	All
<b>Minimum order</b>	10 units
<b>Setup fee</b>	Yes



## Plastic Shells in Custom Colours

If Chairik needs to match a specific design or interior theme, it is possible to customise the Chairik plastic shells in any RAL or NCS colour, ensuring the chair can either perfectly complement or create a striking contrast with its surroundings.

<b>Fits models</b>	Chairik & Chairik XL
<b>Minimum order</b>	100 units
<b>Setup fee per colour</b>	Yes
<b>Additional cost</b>	Yes

# Chairik surfaces — shell / pad

## Materials

Chairik is available in melamine, recycled polypropylene, and polypropylene.

Chairik models made from 100% recycled PP plastic feature a structured, uniform surface on both the front and back. The XL models in PP have a subtle horizontal texture on the front and a glossy finish on the back.

### Recycled PP

101, 107, 109, 111, 113, 117, 119

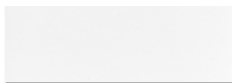

PP Snow 38P



PP Mushroom 137P



PP Amber 142P



PP Beetroot 165P



PP Flint 148P



PP Parsley 152P



PP Anthracite 04P



PP Black 05P

### Polypropylene

All XL Chairik models



PP Snow 38P



PP Black 05P

### Melamine

All Chairik models

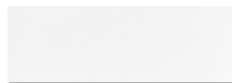

Melamine Snow 38M



Melamine Mushroom 137M



Melamine Amber 142M



Melamine Flint 148M



Melamine Anthracite 04M



Melamine Black 05M

### Melamine Veneer

All Chairik models



Melamine Oak finér 134M

# Chairik surfaces — bases

## Materials

Chairik 4-leg and sled base models without armrests are available in selected Montana colours and chrome.

Chairik with star base, with or without armrests, is available in chrome and black, with the exception of CH148XL and CH149XL.

Chairik models with armrests are available in chrome.

### Powder-Coated Steel

101, 107, 117, 119

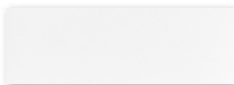

Powder Coat Snow 38



Powder Coat Mushroom 137



Powder Coat Amber 142



Powder Coat Beetroot 165



Powder Coat Flint 148



Powder Coat Parsley 152



Powder Coat Anthracite 04



Powder Coat Black 05

### Powder-Coated Steel

121XL, 127XL

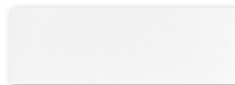

Powder Coat Snow 38



Powder Coat Mushroom 137



Powder Coat Amber 142



Powder Coat Flint 148



Powder Coat Anthracite 04



Powder Coat Black 05

### Recycled PP

148XL, 149XL



PP - Black

### Chrome

101, 107, 109, 111, 113, 117, 119, 121XL, 123XL, 127XL, 128XL, 129XL



Chrome Chrome 44C

### Polished Aluminium

134XL, 135XL, 136XL, 137XL



Aluminium 45P



# Chairik upholstery

---

## Fabrics

All Chairik models can be configured with seat upholstery, front upholstery, full upholstery, or thick full upholstery. Montana Furniture offers a wide range of upholstery fabrics from reputable suppliers such as Kvadrat and Gabriel.

## Leather

Montana Furniture offers high-quality leather upholstery, including options from Sørensen Leather and Nevotex.

- **Pigmented Leather** (e.g., Ultra): Pigmented leather has been surface treated. It is durable and easy to maintain. It resists stains and provides a uniform appearance.
- **Aniline Leather** (e.g., Elegance and Copenhagen): Made from the finest raw hides. The natural surface structure is preserved, providing optimal seating comfort. Daily use adds unique character to the leather.

To view the full range: Visit the suppliers' website or visit a retailer/showroom.

If a colour different from the standard leather colours is desired, this is possible upon request and using whole hides.

### Price Group 1

---

**FABRIC**  
STAMSKIN TOP  
XTREME\*  
VALENCIA  
REMIX\*  
CYBER\*  
RENEWED LOOP\*

### Price Group 2

---

**FABRIC**  
FAME\*  
RE-WOOL\*  
RAAS\*  
SABI\*

### Price Group 3

---

**FABRIC**  
TONUS\*  
STEELCUT\*  
STEELCUT TRIO\*  
HALLINGDAL\*  
UMBER\*

### Price Group 4

---

**LEATHER**  
ULTRA (Black: 41599, Brandy: 41574)  
SIERRA (Black: 1001, Cognac: 1003, Grey: 1007,  
Calvados: 1070, Stone: 1611)  
ORGANIC (Black)  
DAKAR (Cognac, Black)

### Price Group 5

---

**LEATHER**  
COPENHAGEN (Black: 1100450, Cognac: 1100451)  
SAVANNE

### Price Group 6

---

**LEATHER**  
ELEGANCE (Black: 20198)



\*All textiles with a star are EU Ecolabel certified.

**Note:** Price groups are divided based on the fabric, leather, or material qualities that best highlight each piece of furniture. Therefore, the contents of these price groups may vary between different product series.



# Marée

5 models / Design: Jens Martin Skibsted



## Shell Chair

Marée is characterised by a refined and rational design approach, expressed in its clean lines and the absence of unnecessary details. The name "Marée," which means tide in French, refers to the chair's seat, made from 100% recycled plastic, available in eight selected Montana colours, with legs in both chrome and lacquer finishes.

### Technical Information

The Marée chair series comes in many models – Dining, Counter, and Bar – as well as an office chair with a 4-star base, 5-star swivel base with gas lift and tilt, featuring a base made from recycled plastic Ø70 cm or black aluminium Ø64 cm. The chairs have plastic gliders. Marée has a maximum weight capacity of 150 kg. The dining chair version is also available in an outdoor version.

The Marée chair is available as a shell chair, with seat upholstery, inside upholstery, and full upholstery, making it ideal for private homes, hotel interiors, and meeting rooms. The frame is made from polished chrome steel or powder-coated steel. The shell is moulded from 100% cast recycled PP plastic with 15% glass fibre.

# Marée overview

---



4-leg, Dining Chair

190

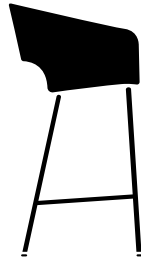

4-leg, Counter

190



4-leg, Bar

190



4-star Base

190



5-star Base with Castors

190



Components

191



Surfaces

192

# Marée



4-leg

**Marée 401** H 77 × SH 46 × D 51 × W 55.5 cm

MAR401

### Frame & Material

The frame is made from 18 mm tubes, powder-coated. The seat is made from form-pressed recycled PP plastic. It is available as un-upholstered, upholstered inner side, seat, with upholstered inner side, seat & back, or fully upholstered.

### Certificates and Test

EU-Ecolabel (only non-upholstered), EN 16139

Marée 401 / Outdoor chair

MAROD1

### Frame & Material

Only non-upholstered)

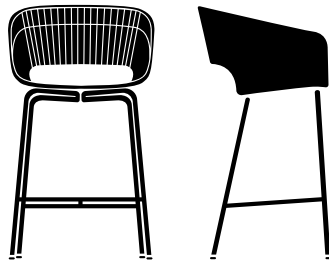

4-leg

**Marée 402** H 97 × SH 66 × D 51 × W 55.5 cm

MAR402

### Frame & Material

The frame is made from 18 mm tubes, powder-coated. The seat is made from form-pressed recycled PP plastic. It is available in non-upholstered, with seat interior upholstery, with seat and back interior upholstery, and fully upholstered versions.

### Certificates and Test

EU-Ecolabel (only non-upholstered) EN 16139

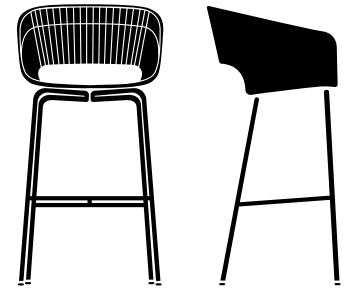

4-leg

**Marée 403** H 107 × SH 76 × D 51 × W 55.5 cm

MAR403

### Frame & Material

The frame is made of 18 mm tubing, powder-coated. The seat is formed from recycled PP plastic. Available in non-upholstered, seat interior upholstery, seat and back interior upholstery, and fully upholstered versions.

### Certificates and Test

EU-Ecolabel (only non-upholstered) EN 16139

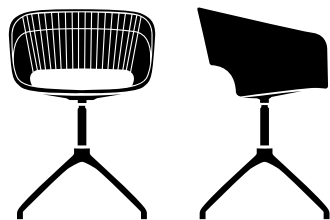

4-star

**Marée 404** H 79.5 × SH 46.5 × D 50 × W 55.5 cm

MAR404

### Frame & Material

The frame is made of powder-coated black aluminium with a return swivel. The seat is formed from recycled PP plastic. Available in non-upholstered, seat interior upholstery, seat and back interior upholstery, and fully upholstered versions.



5-star

**Marée 405** H 73-85 × SH 40-52 × D 48 × W 55.5 cm. (Base Ø64 cm)

MAR405

### Frame & Material

Base in black powder-coated aluminium with brake-equipped castors (soft treads). Seat shell in compression moulded recycled polypropylene. Available as non-upholstered, upholstered inner side seat, upholstered inner side seat and back, or fully upholstered.



5-star

**Marée 406** H 73-85 × SH 40-52 × D 48 × W 55.5 cm. (Base Ø70 cm)

MAR406

### Frame & Material

Base in black recycled plastic with brake-equipped castors (soft treads). Seat shell in compression moulded recycled polypropylene. Available as non-upholstered, upholstered inner side seat, upholstered inner side seat and back, or fully upholstered.

### Certificates and Test

EN 16139

# Marée components

---

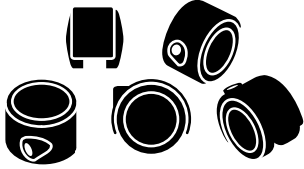

## Double Wheel Castors

with brake, soft treads for hard floors

---

**CC01**

**Material**

Plastic, black



## Glides without Felt

---

**KER24** - 4 pieces.

**Model**

Glides without felt, steel  
frame



## Glides with Felt

---

**KEFILT** - 4 pieces.

**Model**

Glides with felt, steel frame

# Marée surfaces — shell / base

---

## Materials

On the next page, you will find price groups and colour samples of fabric and leather qualities for the upholstered variants.

### Recycled PP

All

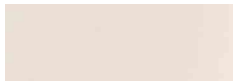

PP Oat 158P



PP Mushroom 137P



PP Amber 142P



PP Beetroot 165P



PP Flint 148P



PP Parsley 152P



PP Anthracite 04P



PP Black 05P

### Powder-Coated Steel

4-leg base

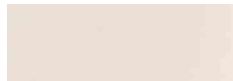

Powder Coat Oat 158



Powder Coat Mushroom 137



Powder Coat Amber 142



Powder Coat Beetroot 165



Powder Coat Flint 148



Powder Coat Parsley 152



Powder Coat Anthracite 04



Powder Coat Black 05



# Marée upholstery

---

## Upholstery

The upholstered Marée models can be configured with seat upholstery, inner side upholstery, or full upholstery. Montana Furniture offers a wide range of textile options from quality-conscious suppliers such as Kvadrat and Gabriel.

## Leather

Montana Furniture provides top-quality leather upholstery from renowned suppliers including Sørensen Leather and Nevotex.

- **Pigmented leather** (e.g. Ultra): This leather has a surface treatment, making it durable, easy to maintain, and resistant to stains, with a consistent appearance.
- **Aniline leather** (e.g. Elegance and Copenhagen): Made from the finest hides, it retains its natural surface structure for optimal seating comfort. With daily use, the leather develops a unique character.

To explore the full selection, visit the suppliers' websites or stop by the Montana Furniture showroom in Copenhagen for guidance on colours and materials.

Alternative colours to the standard leather options are available upon request, using full hides.

### Price Group 1

---

**FABRIC**  
STAMSKIN TOP  
XTREME\*  
VALENCIA  
REMIX\*  
CYBER\*  
RENEWED LOOP\*

### Price Group 2

---

**FABRIC**  
FAME\*  
RE-WOOL\*  
RAAS\*  
SABI\*  
MADS NØRGAARD

### Price Group 3

---

**FABRIC**  
TONUS\*  
STEELCUT\*  
STEELCUT TRIO\*  
HALLINGDAL\*  
UMBER\*

### Price Group 4

---

**LEATHER**  
ULTRA (Black: 41599, Brandy: 41574)  
SIERRA (Black: 1001, Cognac: 1003, Grey: 1007,  
Calvados: 1070, Stone: 1611)  
ORGANIC (Black)  
DAKAR (Cognac, Black)

### Price Group 5

---

**LEATHER**  
COPENHAGEN (Black: 1100450, Cognac: 1100451)  
SAVANNE

### Price Group 6

---

**LEATHER**  
ELEGANCE (Black: 20198)



\*All textiles with a star are EU Ecolabel certified.

**Note:** The price groups are divided according to the fabric, leather, or material qualities that best complement each individual piece of furniture. As a result, the content of these price groups may vary across the different product series.



# Panton One

4 models / Design: Verner Panton

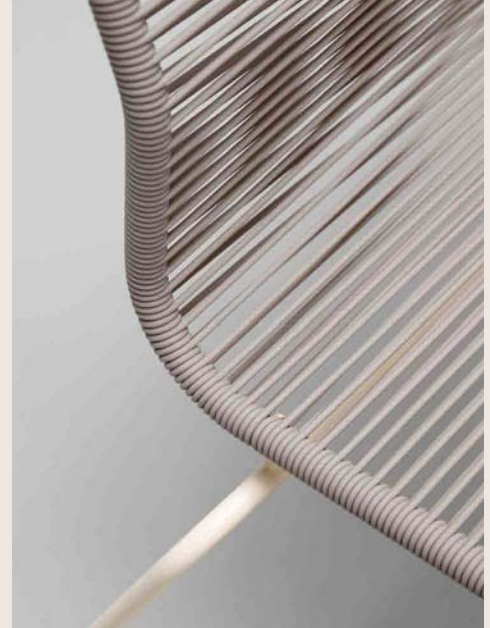

## Chair Series with Woven Seat

The Panton One chair series, designed in 1958, is a stackable and flexible chair with a light and timeless expression. It allows for customised combinations of cord and frame. The series includes four versions: Dining, Kitchen, Lounge and Bar. Panton One is EU Ecolabel-certified, and the models Panton One, Panton One Bar and Panton One Kitchen are also available with FSC®-certified paper cord, made from sustainably sourced wood.

### Technical Information

The seats of the Panton One chairs are hand-woven with cords made of polyurethane with a nylon core, available in a range of colours, or in FSC®-certified paper cord in two colours. The surface texture of the cords may vary. The polyurethane cords are UV-resistant, though some discolouration may occur after prolonged exposure to direct sunlight.

Chairs with a stainless steel frame and polyurethane cord are suitable for both indoor and outdoor use. Chairs with a lacquered frame, chrome frame, or paper cord are not suitable for outdoor use. All chairs are fitted with plastic glides and supplied with felt glides.

The chairs can be stacked up to 10 pcs on a trolley or floor. Maximum load: 150 kg. The Lounge chair is not available in paper cord or with a chrome frame.

# Panton One overview

---

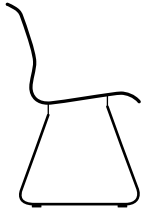

Dining

196



Counter

196

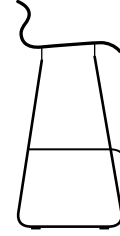

Bar

196

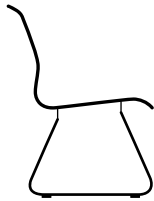

Lounge

196



Components

197



Surfaces

198

# Panton One

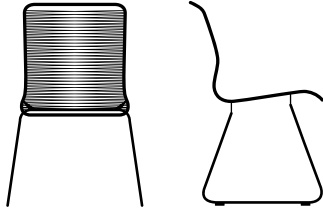

Panton One H 87 x SH 49 x D 55 x W 54 cm

VPTI

## Base

Base made from 13 mm tube, available in stainless steel, chrome, or powder-coated finish.

The seat and backrest are hand-woven in either polyurethane cord with a nylon core or in paper cord.

Chairs with a stainless steel base and polyurethane cord are suitable for both indoor and outdoor use.

This version is stackable up to a maximum of 10 chairs.

## Certificates and Test

EU Ecolabel (polyurethane cord only)  
EN 15373

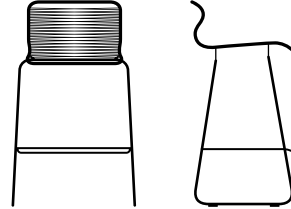

Panton One H 83 x SH 65 x D 44 x W 50 cm

VPTKIT

## Base

Base made from 13 mm tubular steel in stainless steel, chrome or powder-coated finish.

The seat and backrest are hand-woven in polyurethane cord with a nylon core, or in paper cord.

Bases in stainless steel combined with polyurethane cord are suitable for both indoor and outdoor use.

## Certificates and Test

EU Ecolabel (polyurethane cord only)  
EN 15373

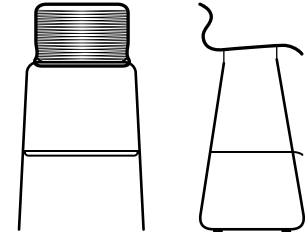

Panton One H 94 x SH 76 x D 44 x W 51 cm

VPTB

## Base

Base made from 13 mm tubular steel in stainless steel, chrome, or powder-coated finish.

The seat and backrest are hand-woven in polyurethane cord with a nylon core or in paper cord.

Bases in stainless steel combined with polyurethane cord are suitable for both indoor and outdoor use.

## Certificates and Test

EU Ecolabel (polyurethane cord only)  
EN 15373

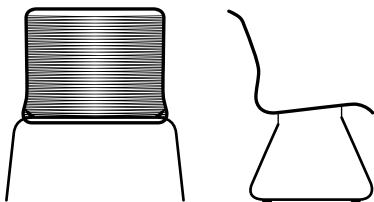

Panton One H 78 x SH 40 x D 59 x W 76 cm

VPTL

## Base

Base made from 14 mm tubular steel in stainless steel or powder-coated finish.

The seat and backrest are hand-woven in polyurethane cord with a nylon core.

The lounge chair is not available with paper cord or chrome finish.

Not suitable for outdoor use.

## Certificates and Test

EU Ecolabel (polyurethane cord only)  
EN 15373

# Panton One components

---



## Felt Glides for Pantone One

### VPSHOE

Plastic glides with self-adhesive felt for Pantone One. Set of 4 pieces.  
The chair is delivered with clear plastic glides.



## Felt Pads for Pantone One Glides

### VPFILT

Set of self-adhesive felt pads for Pantone One glides. Felt pads are recommended for wooden floors and other smooth surfaces.

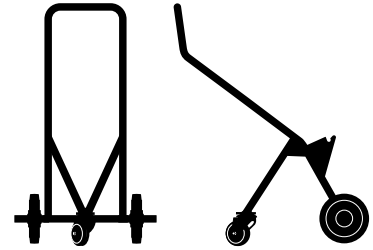

## Pantone One Trolley

### VPVOGN

H 97.5 x W 57 x D 78.5 cm. Transport trolley for Pantone One chairs. Holds up to 10 stacked chairs. Made of powder-coated steel.

# Panton One surfaces

## Materials

The seats of the Panton One chairs are hand-woven with cords made of polyurethane with a nylon core, available in 4 different colours, or in paper cord available in 2 colours. When combined with a stainless steel frame and polyurethane cord, the chairs are suitable for both indoor and outdoor use.

Lacquered frames, chrome frames, and paper cord are not suitable for outdoor use.

### Stainless Steel Frame



Steel 99 Stainless Steel

### Chrome Frame VPTI, VPTB, VPTKIT



Chrome 43 Chrome

### Powder-Coated Frame

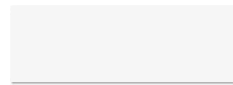

Powder Coat 38 Snow



Powder Coat 05 Black

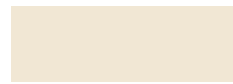

Powder Coat 15 Beige



Powder Coat 07 Black Red

### Cord Colours Polyurethan



Polyurethan 605 Clark



Polyurethan 609 Marcel



Polyurethan 604 Holmes



Polyurethan 607 Carmen

### Cord Colours Paper VPTI, VPTB, VPTKIT



Paper 601 Paper Nature



Paper 602 Paper Black





# Joint

1 model / Design: Anders Hermansen



## Exclusive Meeting and Office Chair

Joint is a luxurious meeting chair designed for offices, meeting rooms, and conference spaces. The chair features a five-star swivel base and a polished aluminium frame that combines durability with a refined, minimalist appearance. The elegant frame embraces the seat in a way that conveys either a feminine or masculine character, depending on the chosen materials. For optimal comfort, Joint is equipped with a tilt mechanism, providing flexible seating comfort. No matter the angle, the chair exudes exceptional balance and sophistication.

### Technical Information

The Joint chair features a five-star swivel base, polished aluminium frame, and upholstery options in mesh, webbing, fabric, or leather. The chair includes a tilt mechanism to ensure dynamic seating comfort.

# Joint overview

---



---

**5-star Base with Castors**

202

**Components**

202

**Surfaces**

203

# Joint components

---



5-star

**Joint 1211** H 86-93 x SH 45-50 x D 69 x W 69 cm

J1211

## Frame & Material

Frame in polished aluminium with integrated armrests and 5-star base.

The chair features height adjustment, tilt function, and 360° rotation.

Equipped with double castors without brakes, featuring aluminium caps and soft treads.

Available in black mesh, upholstered inner side with back in Backweave, and fully upholstered versions.

## Note

Available while stocks last.

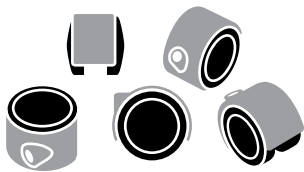

## Double Castors

with alu caps without brakes

### JR1

**Model** Joint 1211  
**Material** Black plastic with hand-polished aluminium caps.



## Gas Cartridge

### JR2

**Model** Joint 1211  
**Material** Polished aluminium.



# Joint upholstery

---

## Upholstery

Montana Furniture offers a wide range of textile upholstery options from quality-conscious suppliers such as Kvadrat and Gabriel. For the JOINT series, webbing from Elas and mesh from Italian manufacturer Serge Ferrari are also available.

## Leather

Montana Furniture provides high-quality leather upholstery from suppliers such as Sørensen Leather and Nevotex.

Aniline leather (e.g. Elegance and Copenhagen): Made from top-grade hides, the natural surface structure is preserved, offering optimal seating comfort. Daily use gives the leather a distinctive and unique character.

To view the full selection, visit the suppliers' websites or stop by a Montana Furniture showroom or dealer.

Alternative colours to the standard leather range are available upon request and require the use of full hides.

---

### Price Group 1

FABRIC  
REMIX\*

---

### Price Group 2

FABRIC  
FAME\*  
RE-WOOL\*  
RAAS\*  
SABI\*

---

### Price Group 3

FABRIC  
TONUS\*  
STEELCUT\*  
STEELCUT TRIO\*  
HALLINGDAL\*  
UMBER\*

---

### Price Group 4

LEATHER  
ULTRA (Black: 41599, Brandy: 41574)  
SIERRA (Black: 1001, Cognac: 1003,  
Grey: 1007, Calvados: 1070, Stone: 1611)  
ORGANIC (Black)  
DAKAR (Cognac, Black)

---

### Price Group 5

LEATHER  
COPENHAGEN (Black: 1100450, Cognac: 1100451)  
SAVANNE

---

### Price Group 6

LEATHER  
ELEGANCE (Black: 20198)

---

### Webbing

BLACK



\*All textiles with a star are EU Ecolabel certified.

**Please note:** Price groups are organised according to the fabric, leather or material qualities that best complement each piece of furniture. As a result, the contents of these price groups may vary between different product series.



# Paradigm

4 models / Design: Erik Rasmussen



## Modular Sofa

The Paradigm modular sofa consists of a straight module, a pouf, and a left and right corner module. Paradigm can easily be altered, expanded, or divided as new needs arise. The modules can even be reversed, or the pouf can be used as an insert between modules with backs. The sofa features a removable cover and is easy to disassemble, making it simple to replace components. This makes Paradigm a sustainable and long-lasting investment. Additionally, there are two types of feet, linking brackets, and the option to integrate Powerdot.

### Technical Information

Paradigm comes standard with feet at a height of 2.5 cm, but can also be ordered with 5 cm high feet to facilitate floor cleaning without the risk of damaging the fabric on the modules. All modules are equipped with connecting brackets underneath, ensuring easy and stable assembly. The fabric is removable and secured with Velcro underneath. The removable fabric should only be dry-cleaned. Loose covers can be purchased in all fabric types. Powerdot can be integrated into the corner modules – please specify when ordering.

Paradigm can be manufactured with fire-retardant foam for an additional charge – contact Montana for prices and orders. However, please note that the fire-retardant foam is not EU-Ecolabel certified. The product is EU-Ecolabel certified when chosen with a fabric cover that also holds the EU-Ecolabel certification.

# Paradigm overview

---

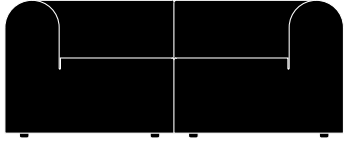

---

**Pre-designed** 206



---

**Design your Own** 207



---

**Components** 209



---

**Surfaces** 211

# Paradigm pre-designed

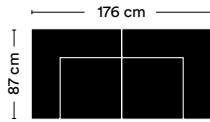

PAR2A0

H: 71,5 cm

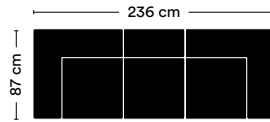

PAR3A0

H: 71,5 cm

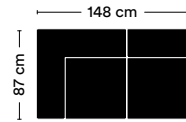

PAR2OR

H: 71,5 cm

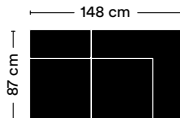

PAR2OL

H: 71,5 cm



PAR3PR

H: 71,5 cm

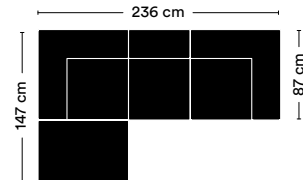

PAR3PL

H: 71,5 cm

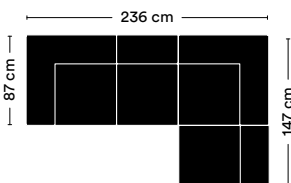

PAR4OR

H: 71,5 cm

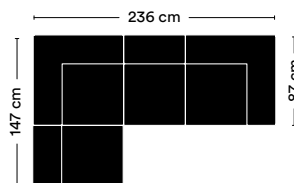

PAR4OL

H: 71,5 cm

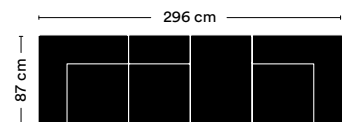

PAR4PR

H: 71,5 cm

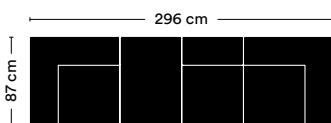

PAR4PL

H: 71,5 cm

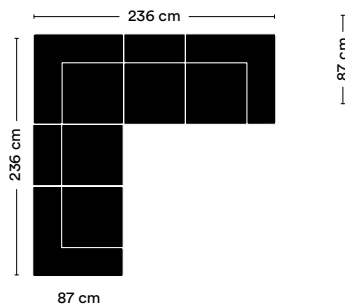

PAR5CO

H: 71,5 cm

# Paradigm design your own

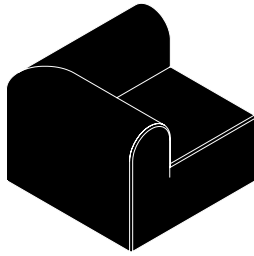

**PARSCA** W 88 x H 71.5 / SH 41.5 x D 87 cm

### Left Corner Module

The cover is removable and is recommended to be dry-cleaned. The corner module can be ordered with Powerdot integrated into the front edge of the left arm. The standard feet height is 2.5 cm, but feets can be purchased in 5 cm height.

281 kg CO<sub>2</sub>e\* per corner module.

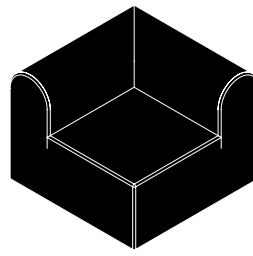

**PARSCC** W 88 x H 71.5 / SH 41.5 x D 87 cm

### Right Corner Module

The cover is removable and is recommended to be dry-cleaned. The corner module can be ordered with Powerdot integrated into the front edge of the right arm. The standard feet height is 2.5 cm, but feets can be purchased in 5 cm height.

281 kg CO<sub>2</sub>e\* per corner module.

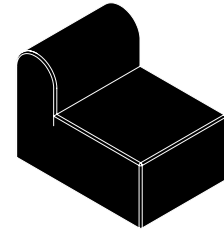

**PARSSB** W 60 x H 71.5 / SH 41.5 x D 88 cm

### Straight Module

The cover is removable and is recommended to be dry-cleaned. It cannot be ordered with Powerdot. The standard feet height is 2.5 cm, but feets can be purchased in 5 cm height.

163 kg CO<sub>2</sub>e\* per straight module.

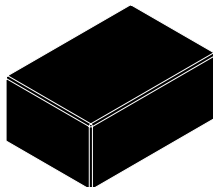

**PARSPD** W 88 x H 41.5 x D 60 cm

### Pouf with Removable Cover

The cover is recommended to be dry-cleaned. It cannot be ordered with Powerdot. The standard feet height is 2.5 cm, but feets can be purchased in 5 cm height.

115 kg CO<sub>2</sub>e\* per pouf.

\*Figures are averages and vary depending on chosen upholstery. Calculated by supplier LTP Furniture, based on the GHG Protocol and a cradle-to-gate approach. Includes materials, transportation, energy use and production waste, allocated by production time. Data from 2024–2025. Not third-party verified. Further documentation available upon request.

# Paradigm

EU ECOLABEL CERTIFIED

## Components

Paradigm is supported by a small, carefully considered set of components that enhance flexibility, comfort and longevity. The system includes removable covers, linking brackets, two leg height options and the optional integration of Powerdot in the corner modules. These components allow the sofa to be reconfigured, expanded or refreshed over time, supporting both functional adaptation and long-term use in residential and contract settings.



# Paradigm components



## Removable Cover

Sold separately per module type

**PARCCA:** Removable cover for left element

**PARCCC:** Removable cover for right element

**PARCSB:** Removable cover for straight element

**PARCPD:** Removable cover for pouf

Material can be selected from various textiles, see the overview on the next page.

For removable covers for corner elements with Powerdot, please contact Montana for ordering.



## Standard feet

**PARLEG:** Standard feet:

Ø4 cm, 2.5 cm high, in black-stained wood.

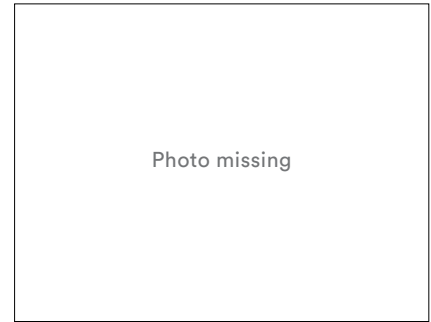

## High feet

**PARLEG:** High feet:

Ø6 cm, 5 cm high, in black-stained wood.



## Powerdot

**Model:** PARSCA & PARSCC Corner Modules

**Material:** Black plastic.

Installed in the arm of the corner module, with the center placed 15 cm from the floor and 14 cm from the outer edge of the arm. The diameter of the Powerdot is Ø7.1 cm. For Switzerland, the diameter is Ø8.3 cm.

**Please note,** the Powerdot cannot be retrofitted.

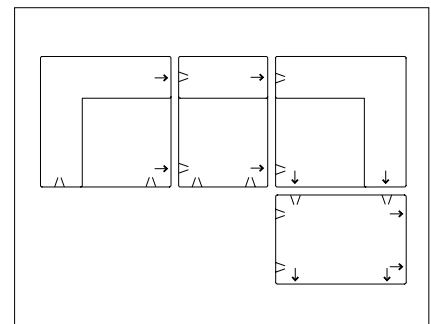
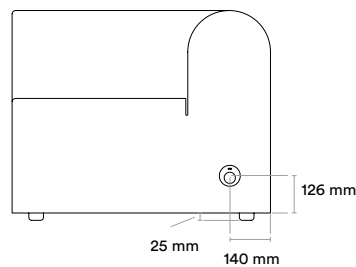
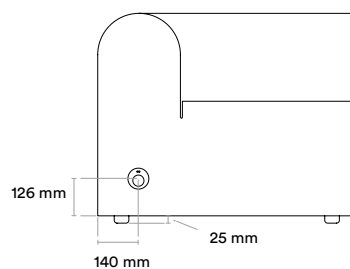

## Linking brackets

The illustration shows the placement of linking brackets on the respective module types.

# Paradigm surfaces

## Kvadrat Remix 3



Remix 3 - 123\*



Remix 3 - 433



Remix 3 - 346\*



Remix 3 - 373\*



Remix 3 - 773



Remix 3 - 982

## Kvadrat Technicolour



Technicolour - 0520



Technicolour - 0260\*



Technicolour - 0210\*



Technicolour - 0370



Technicolour - 0230



Technicolour - 0860\*

## Kvadrat Sabi



Sabi - 171



Sabi - 291\*



Sabi - 551



Sabi - 581

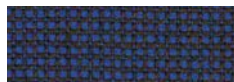

Sabi - 771\*



Sabi - 791\*

## Kvadrat Re-wool



Re-wool - 218\*



Re-wool - 718



Re-wool - 858



Re-wool - 977



Re-wool - 377



Re-wool - 397\*

## Kvadrat Hero 2



Hero 2 - 912\*



Hero 2 - 942



Hero 2 - 242\*



Hero 2 - 432



Hero 2 - 732\*



Hero 2 - 782

## Kvadrat Steelcut 3



Steelcut 3 - 240\*

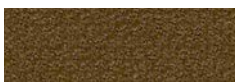

Steelcut 3 - 265



Steelcut 3 - 695



Steelcut 3 - 985\*



Steelcut 3 - 975\*



Steelcut 3 - 732

## Kvadrat Hallingdal 65



Hallingdal 65 - 220\*

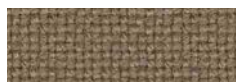

Hallingdal 65 - 224

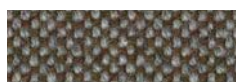

Hallingdal 65 - 270

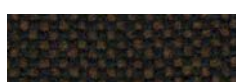

Hallingdal 65 - 370



Hallingdal 65 - 764\*



Hallingdal 65 - 166\*

## Gabriel Nobel



Nobel - 61296



Nobel - 64272



Nobel - 61300\*



Nobel - 66266\*



Nobel - 68303\*



Nobel - 60353

## Kvadrat Vidar 4



Vidar 4 - 146\*



Vidar 4 - 333\*

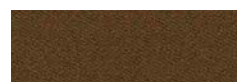

Vidar 4 - 363\*



Vidar 4 - 386\*



Vidar 4 - 786



Vidar 4 - 972

\*Selected fabrics displayed on our website.



All textiles are  
EU Ecolabel  
certified.



# Paradigm upholstery

---

## Construction

The modules are constructed with foam bonded to the sofa frame to ensure stability, shape retention, and long-term durability in daily use. At the same time, the construction is designed with service life in mind, allowing key components to be replaced when needed. Upholstery, legs, and other parts can be easily removed and replaced, and materials are selected with a focus on responsible handling at end of life.

- **Frame structure:** The module frames are made from PEFC-certified particleboard, ensuring a responsible choice of materials.
- **Seat and back:** The seat and back modules are made of PUR foam, bonded to the frame to provide high comfort, stable support, and long-lasting shape retention.
- **Upholstery:** The upholstery is removable and secured with Velcro to the sofa frame, both internally and along all four sides of the module. The modules are closed at the bottom but equipped with a zipper, allowing easy access to the frame when changing the upholstery.

## Modular system

All modules are fitted with connecting brackets that allow the modules to be pushed together and secured in the desired configuration. The modules can easily be detached from the brackets if the sofa is to be rearranged into a new formation.

## Textile options

Montana Paradigm is available in a selection of different textiles. See the overview below for details. All fabric samples can be found on the previous page.

---

### Price Group 0

FABRIC  
GUEST

---

### Price Group 1

FABRIC  
(KVADRAT) REMIX 3  
(KVADRAT) TECHNICOLOUR  
PARCEL LOOP (Gabriel)

---

### Price Group 2

FABRIC  
(KVADRAT) SABI  
(KVADRAT) RE-WOOL  
(KVADRAT) HERO 2  
(KVADRAT) FAME  
(KVADRAT) HAKU

---

### Price Group 3

FABRIC  
(KVADRAT) STEELCUT  
(KVADRAT) HALLINGDAL 65  
(KVADRAT) Steelcut Trio  
(GABRIEL) NOBEL

---

### Price Group 4

FABRIC  
(KVADRAT) VIDAR 4



# Pantonova

3 models / Design: Verner Panton



## Modular Wire Seating

The Pantonova system, designed by Verner Panton in 1971, consists of three different seating modules: Linear, Concave, and Convex. These sculptural chairs can be used individually as elegant sculptural pieces or freely combined into fluid organic shapes, such as a circle, semicircle, wave, or S-shape.

### Technical Information

The Pantonova system is made of 5 mm steel wire and is available in either chrome-plated or powder-coated steel in Black or Red. Additionally, the system is available in an outdoor version in electro-polished stainless steel. The modules can be combined in various formations using connection brackets and clips, and for closed configurations, additional tools are required. The chairs come with plastic feet and have a maximum load capacity of 130 kg per module.

Optional cushions are available for purchase, made from leather, velvet, or fabric from Kvadrat.

# Pantonova overview

---

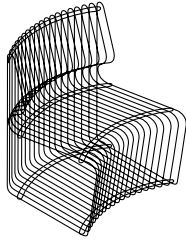

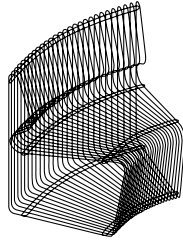

---

**Linear 105RS** 214



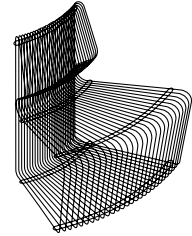

---

**Concave 106RS** 214

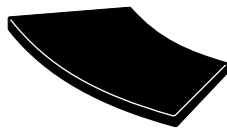

---

**Convex 107RS** 214



---

**Components** 215



---

**Surfaces** 217

# Pantonova

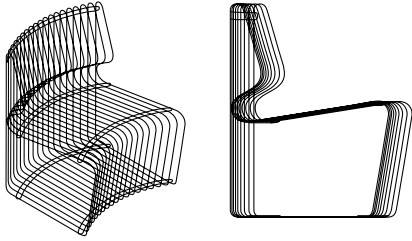

**Linear 105RS** H 73 x SH 40 x D 62 x W 55 cm

105RS

### Frame

The linear module is made from 5 mm wire and is available in chrome, powder-coated, or stainless steel for outdoor use. It comes with black plastic feet.

### Cushions

Cushions are available for purchase (Panseatlin).

### Certificates and Test

EU Ecolabel. EN 1022. EN 16139

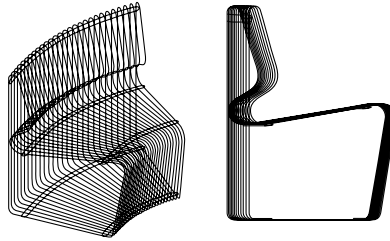

**Concave 106RS** H 73 x SH 40 x D 58 x W 79 cm

106RS

### Frame

The concave module is made from 5 mm wire and is available in chrome, powder-coated, or stainless steel for outdoor use. It comes with black plastic feet.

### Cushions

Cushions are available for purchase (Panseatcav).

### Certificates and Test

EU Ecolabel. EN 1022. EN 16139

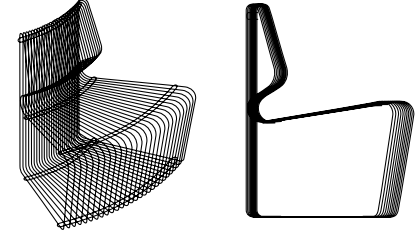

**Convex 107RS** H 73 x SH 40 x D 58 x W 77 cm

107RS

### Frame

The convex module is made from 5 mm wire and is available in chrome, powder-coated, or stainless steel for outdoor use. It comes with black plastic feet.

### Cushions

Cushions are available for purchase (Panseatvex).

### Certificates and Test

EU Ecolabel. EN 1022. EN 16139

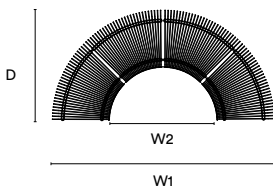

**Half Circle** D: 104 / W1: 208 / W2: 98 cm

The setup consists of 4 x Concave 106RS modules.

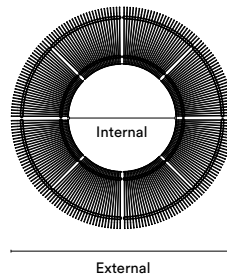

**Circle** External 208 cm  
Internal 98 cm

The setup consists of 8 x Concave 106RS modules.

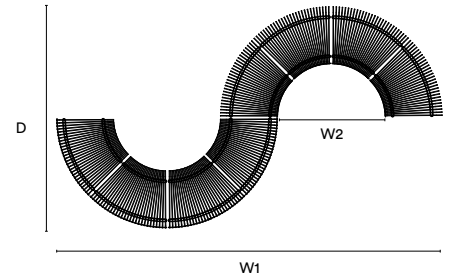

**S-shape** D: 208 / W1: 360 / W2: 98 cm

The setup consists of 4 x Concave 106RS and 4 x Convex 107RS modules.



# Pantonova

EU ECOLABEL CERTIFIED

## Components

Optional seat cushions add comfort and allow the expression of the system to be tailored through fabric or leather choices, supporting use in both contract and residential settings, while discreet connecting brackets can be used to secure the integrity of larger configurations.

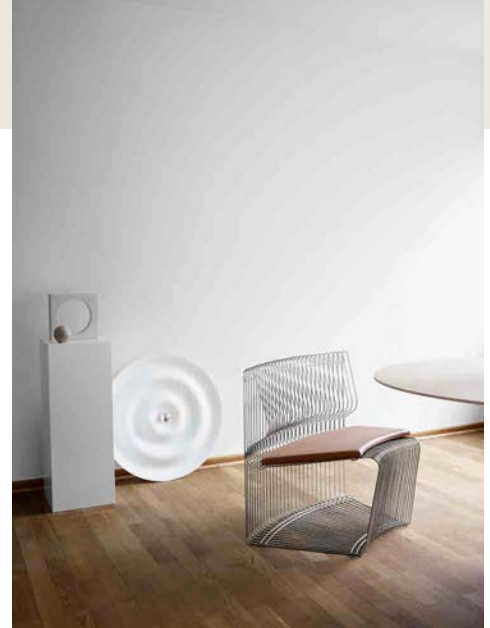

# Pantonova components

---

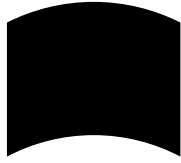

## Linear Cushion

### PANSEATLIN

**Material** Harald, Hallingdal 65 and Leather

**Montering** Cushions are mounted using a retaining ring and round screws in bushings on the back of the cushion.

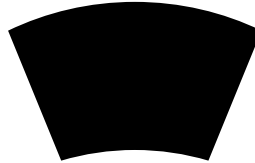

## Concave Cushion

### PANSEATCAV

**Material** Harald, Hallingdal 65 and Leather

**Montering** Cushions are mounted using a retaining ring and round screws in bushings on the back of the cushion.



## Convex Cushion

### PANSEATVEX

**Material** Harald, Hallingdal 65 and Leather

**Montering** Cushions are mounted using a retaining ring and round screws in bushings on the back of the cushion.



## Tool

### PATOOL

**Material** Metal

Installation tool. Used to close linking brackets in closed configurations.



## Mounting Bracket

### PANBRA

**Material** Metal  
**Farve** Chrome, Stainless Steel, and Black Red

Linking bracket + 2 clips. Supplied in chrome, stainless steel, or Black Red.

Note: Chair linking requires a level surface.

# Pantonova surfaces

---

## Materials

### Frame

Pantonova is made from 5 mm wire and is available in chrome, powder-coated in Black Red, or in electro-polished stainless steel for outdoor use. The chairs are fitted with plastic feet.

### Cushions

Cushions can be purchased in the fabrics Harald and Hallingdal 65 from Kvadrat, and Ultra leather from Sørensens Leather. The cushions are 3.5 cm thick and are available in 8 selected colors.

#### Base



Chrome 43 Chrome



Steel 99 Stainless Steel



Powder Coat 07 Black Red

#### Cushions

##### Fabric



823 Velvet Sky,  
Harald



343 Velvet Camel,  
Harald



382 Velvet Aubergine,  
Harald



103 Woven Shell,  
Hallingdal 65



227 Woven Sand,  
Hallingdal 65



190 Woven Black,  
Hallingdal 65

#### Cushions

##### Leather



41574 Leather Cognac,  
Ultra, Sørensens



41599 Leather Black,  
Ultra, Sørensens



# Montana Furniture

## Load capacity overview for chairs



# Load capacity overview for chairs

The table below outlines all max load capacities for chairs.

	Load Capacity	Description
<b>Kevi</b>		
Kevi E2060	140 kg	4-leg, steel
Kevi E2070	140 kg	4-leg, wood base
Kevi E2063	140 kg	4-leg, lounge
Kevi E2061 + 62	140 kg	4-leg, counter & bar
Kevi E2051	150 kg	4-leg, stool
Kevi E2052 + 53	150 kg	4-leg, counter & bar stool
Kevi EAir	150 kg	5-star, office chair
Kevi E2533 + E2534U	150 kg	5-star, office chair
Kevi E2533J	150 kg	5-star, office chair junior
Kevi E2543	150 kg	5-star, office chair
Kevi E2532	150 kg	5-star, taburet

<b>Chairik</b>		
Chairik CH101 + CH121XL	150 kg	4-leg, melamine shell
Chairik CH101	150 kg	4-leg, recycled PP shell
Chairik CH109 + CH129XL	150 kg	4-leg
Chairik CH13 + CH123XL	140 kg	4-leg
Chairik CH107 + CH127XL	140 kg	Sled frame
Chairik CH111 + CH128XL	140 kg	Sled frame
Chairik CH117 + CH119	140 kg	Sled frame
Chairik CH134XL + CH135XL	140 kg	5-star
Chairik CH136XL + CH137XL	140 kg	4-star
Chairik CH148XL + CH149XL	140 kg	5-star

<b>Marée</b>		
Marée MAR401	150 kg	4-leg, dining chair
Marée MAR402 + MAR403	140 kg	4-leg, counter & bar
Marée MAR404	150 kg	4-star base
Marée MAR405	150 kg	5-star base with wheels
Marée MAR406	150 kg	5-star base with wheels

<b>Panton One</b>		
Panton One / VPTI	150 kg	Sled frame
Panton Counter / VPTKIT	150 kg	Sled frame
Panton Bar / VPTB	150 kg	Sled frame
Panton Lounge / VPTL	150 kg	Sled frame

<b>Joint</b>		
Joint 1211	150 kg	5-star base with wheels

<b>Szene</b>		
Szene 301	150 kg	Wall-mounted auditorium chair
Szene 311	150 kg	Cantilever chair / Freestanding

<b>Pantonova</b>		
Linear 105RS	130 kg	
Concave 106RS	130 kg	
Convex 107RS	130 kg	





# OUTDOOR





# Outdoor

8 models



## Outdoor Seating

Montana offers outdoor chairs within three chair series: Pantonova, Panton One, and the dining chair model in the Marée series.



# INDEX — Outdoor

---

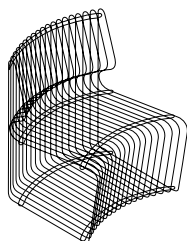

**Pantonova Linear 105RS** 212

Electropolished stainless steel for outdoor use.

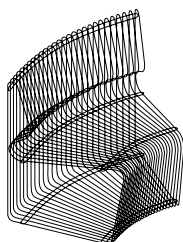

**Pantonova Concave 106RS** 212

Electropolished stainless steel for outdoor use.

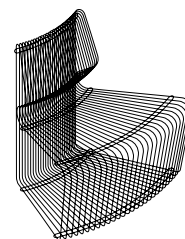

**Pantonova Convex 107RS** 212

Electropolished stainless steel for outdoor use.

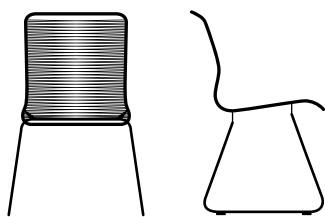

**Pantan One VPTI** 194

With a stainless steel frame and polyurethane cord, the chairs can be used both indoors and outdoors.

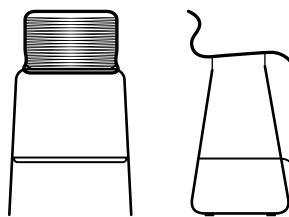

**Pantan One VPTKIT** 194

With a stainless steel frame and polyurethane cord, the chairs can be used both indoors and outdoors.

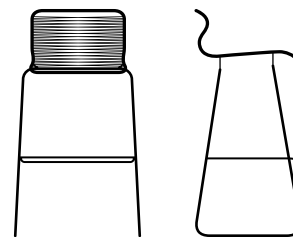

**Pantan One VPTB** 194

With a stainless steel frame and polyurethane cord, the chairs can be used both indoors and outdoors.

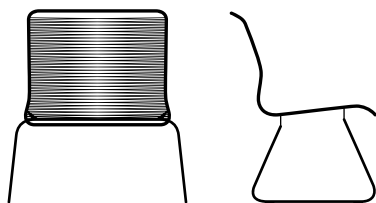

**Pantan One VPTL** 194

With a stainless steel frame and polyurethane cord, the chairs can be used both indoors and outdoors.



**Marée MAROD1** 188

Powder-coated frame and shell in PP plastic, suitable for both indoor and outdoor use.



# TABLES







# INDEX — Tables

---



Monterey

228



JW Table

232

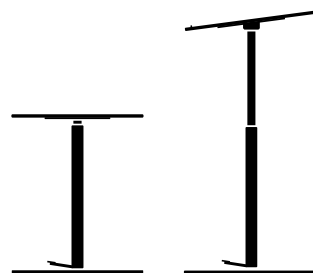

Multi Table

236



Panton Table

242

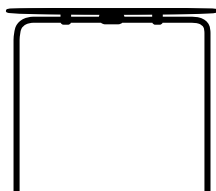

Kevi Table

246

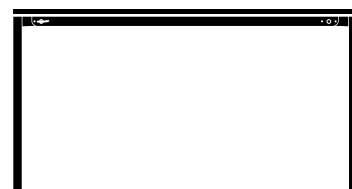

Moser Table

250



Foldit Table

258



Djob Table

263



HiLow Table

266

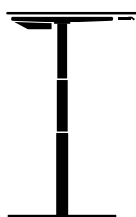

HiLow Speaker

286



SHL Table

291

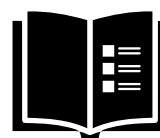

Load Capacity Overview  
for Tables

294



# Monterey

30 mm MDF / Design: Peter J. Lassen



## Tables and Benches

Monterey is a versatile and functional table and bench system, designed to fit various spaces and uses. With its simple and clean design, Monterey can be used as a table, bench, or storage solution in the entryway, living room, bedroom, or children's room – or as a high meeting table for office environments.

### Technical Information

Monterey is made of 30 mm MDF and features the same rounded edges and characteristic corner joints as the Montana System. Monterey can be used as a coffee table, TV stand, bedside tables, a base for Montana shelving units, or a wheeled table. Monterey can support up to 100 kg.

Monterey is available in three standard heights and can be ordered in a custom height range of 10-110 cm at an additional cost. Monterey in the height range of 10-76 cm is supplied with a 4 cm metal support rail, while Monterey in lengths of 100 cm and 80 cm are supplied without a support rail. The metal support rail is lacquered in the same colour as the Monterey unit (see illustration on the next page). Monterey is not delivered as a knockdown product but is securely packaged.

## Monterey Dimensions

Monterey with a height of 77-110 cm is supplied with an MDF support rail with a height of 10 cm. The number of MDF support rails is indicated in the illustration.

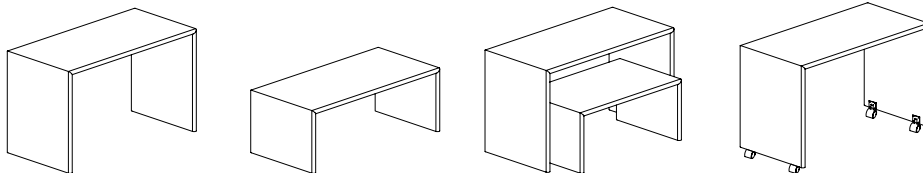

Monterey is available in the following heights:

- H: 45 cm
- H: 74 cm
- H: 105 cm

Monterey in the height range of 77-110 cm is available with a depth of 80 cm and 60 cm, and is supplied with 2 MDF support rails, each 10 cm in height.

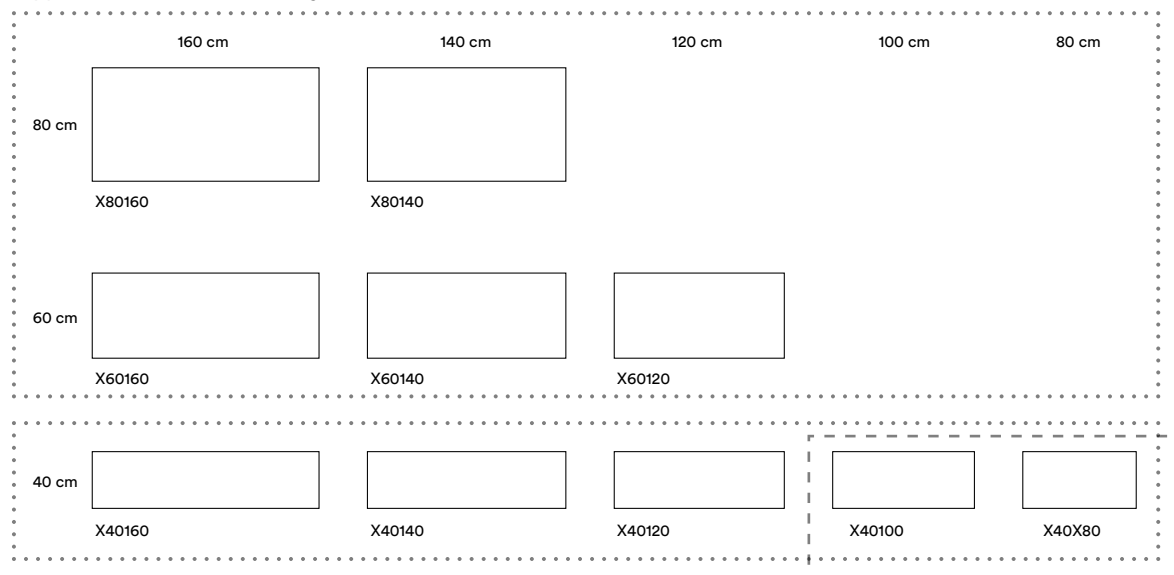

Monterey in the height range of 77-110 cm is available with a depth of 40 cm and supplied with 1 MDF support rail, 10 cm in height.

Lengths of 100 cm and 80 cm are delivered without a metal support rail in the height range of 10-76 cm.

- - - - - Special conditions regarding the metal support rail.
- ..... Special conditions regarding the MDF support rail.



# Monterey surfaces

## Materials

Monterey is made from 30 mm MDF and features the same rounded edges and characteristic corner joints as the Montana System. The metal/MDF support rail is also lacquered in all of Montana's colours and matches the colour of the table or bench.

## Lacquered MDF

Monterey is available in all of Montana's lacquer colours.





# JW Table

Design: Jakob Wagner



## Dining and Meeting Table

The JW Table has a visually light expression with a frame that is recessed under the table. The triangular legs are distinctly shaped and slightly angled outward to create better legroom for guests around the table. Despite its light and slender appearance, the table's structure is solid and stable. The JW Table comes in various standard sizes, both round and rectangular. It is perfect for dining guests in the dining room and for long meetings in the office.

### Technical Information

The JW Table is available with a rectangular or round tabletop in seven sizes. The table can support a maximum load of 80 kg evenly distributed across the surface. Add extra functionality to your JW Table with components. Complete the table with components such as power outlets, socket panels, etc. For more information about components, refer to the HiLow components section on page 278 >.

The frame is made of four die-cast aluminum legs and extruded aluminum rails. The frame is pushed out toward the edges of the table to provide more legroom for the user and to fully utilise the table's potential. The feet are made of soft plastic.

## Table Sizes

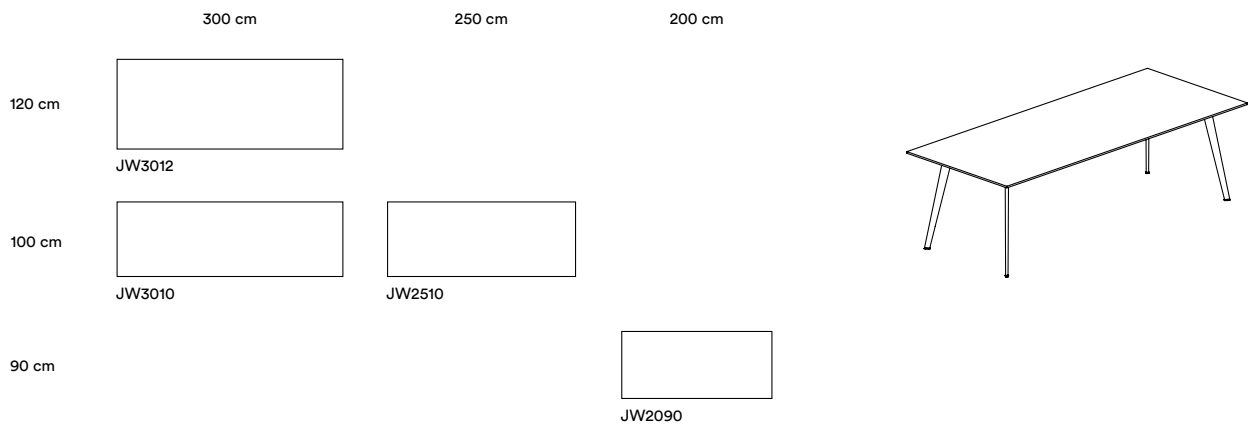

## JW Components

**111090:** L: 315 x W: 125 mm, integrated power outlet with a single flap, available in laminate and linoleum (delivered in the same finish as the tabletop). Not available in veneer or solid wood.

**111093:** L: 325 x W: 130, H: 10 mm, power outlet in solid anodized aluminum or black anodized aluminum with horsehair – double.

**HL111104:** Power panel with 4 Schuko sockets for installation in a power outlet.

**HL111106:** Bracket for power panel, for installation in power outlet.

**1110941:** W: 350 x H: 115 mm, land for power outlet. Must be selected for power outlets placed in the JW Table. Available in aluminum and powder-coated Snow and Black.

# JW Table surfaces

## Materials

The frame is standardly powder-coated in several colours or, at an additional cost, polished aluminum. The frame has aluminum legs and a support rail, with plastic feet. The tabletop surfaces come in laminate, linoleum, veneer, and solid wood. Laminate, linoleum, and veneer are delivered with a plate approximately 2 cm thick, while solid wood tabletops are 3 cm thick. The height of the table with laminate, linoleum, and veneer is 73 cm. The table with solid wood tabletops measures 74 cm in height. The JW140 and JW160 are not available in laminate or nano laminate.

### Linoleum

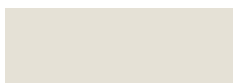

**Linoleum**  
Mushroom / Forbo 4176



**Linoleum**  
Ash / Forbo 4132



**Linoleum**  
Charcoal / Forbo 4166



**Linoleum**  
Nero / Forbo 4023



**Linoleum**  
Mauve / Forbo 4172



**Linoleum**  
Burgundy / Forbo 4154



**Linoleum**  
Pistachio / Forbo 4183



**Linoleum**  
Olive / Forbo 4184



**Linoleum**  
Walnut / Forbo 4003

### Laminate\*

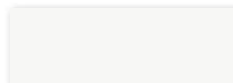

**Laminate 38L** Snow Silk

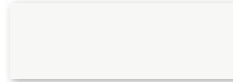

**Laminate 38L** Snow



**Laminate 09L** Nordic



**Laminate 02L** Fjord



**Laminate 04L** Anthracite



**Laminate 157L** Cumin



**Laminate F3050L** Cygnet



**Laminate F8240L** Liquid glass

### Nano Laminate\*



**Nano Laminate**  
0718N Clay



**Nano Laminate**  
0754N Blue Fes



**Nano Laminate**  
0720N Black



**Nano Laminate**  
0789N Rosso Namib

### Veneer



**Veneer White Oak** 131F



**Veneer Nature Oak** 62F



**Veneer Black Oak** 133F

### Solid Wood



**Wood Solid Oak** 300W

\* The JW140 and JW160 are not available in laminate and nano laminate.

# JW Table frame

---

## Frame

The frame is standardly made of powder-coated metal, with an optional upgrade to polished aluminium. The frame features aluminium legs and a support rail, with plastic feet.

### Frame Colour Powder-Coated

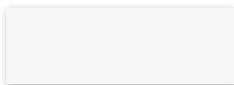

Powder Coat Snow 38



Powder Coat Black 05

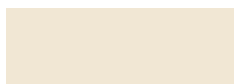

Powder Coat Beige15



Powder Coat Black Red 07



Powder Coat Shadow 147



Powder Coat Pine 136



Powder Coat Pomelo 140



Powder Coat Hokkaido 162

### Frame\* Polished Aluminium



Polished Aluminium 45P

\*Available at an additional cost in polished aluminium.  
Please note that printed colours may differ from the original colour.



# Multi Table

Design: Peter J. Lassen og Joakim Lassen



## Multi-functional Table

The versatile and elegant Multi Tables are ideal for use in kitchen and canteen areas, for meetings and conferences, or as workstations in the office. The series consists of two different types of tables – Multi Café and Multi Speaker. All tables are available in a wide range of colours and sizes for the tabletop, making them a great choice, especially for office environments, canteens, or similar spaces.

### Technical Information

The Multi Café tables come in two different tabletop shapes: round and square, and are available in four standard heights. Additionally, a gas height adjustment option is available, allowing the height to be adjusted from 74 cm to 114 cm. Tables with tabletop sizes larger than 80 × 80 cm cannot be equipped with gas height adjustment. Multi Café tables can support a maximum load of 20 kg.

### Components for Multi Café

Micro powerdot in black or white is available as an option for Multi Café tables with tabletop sizes of Ø60-80 cm. It is placed in the center of the tabletop. Profiles in heights of 45, 72, 90, and 105 cm are designed with cable management. The micro powerdot cannot be chosen for tables with gas height adjustment.

The MCPD cable cover is recommended for café tables with micro powerdot. It is compatible with both USB A and USB C ports.

**MCPD:** The cable cover is recommended for café tables with micro powerdot. Available in Aluminium, Snow, and Black colours.

# Multi Table overview

---

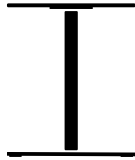

Multi Café

238

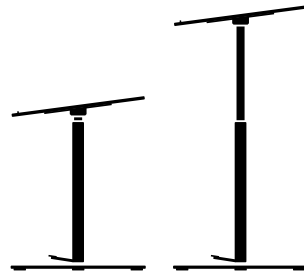

Multi Speaker

239



Surfaces

240

# Multi Café

EU ECOLABEL CERTIFIED

## Café and Lounge Table

The versatile Multi Café tables are perfect for use in kitchens, meetings, or exhibitions, as well as serving as café and lounge tables. The Multi Café tables come in 4 standard heights, with an option for gas height adjustment. The tabletops are available in 2 shapes, various sizes, and a wide selection of finishes and colours, making them a flexible and stylish choice for different environments.



### Multi Café Tables

The Multi Café tables are available in 2 different tabletop shapes: round and square, and come in 4 standard heights. With the exception of tabletop sizes 120 cm, 100 cm, and 90 cm, which are only available in heights 45 cm and 90 cm, the 120 and 100 cm tables are mounted with a large cross base (80 cm). The rest are mounted with a small cross base (60 cm).

All tables feature adjustment screws under the feet, allowing for a 5 mm height adjustment.

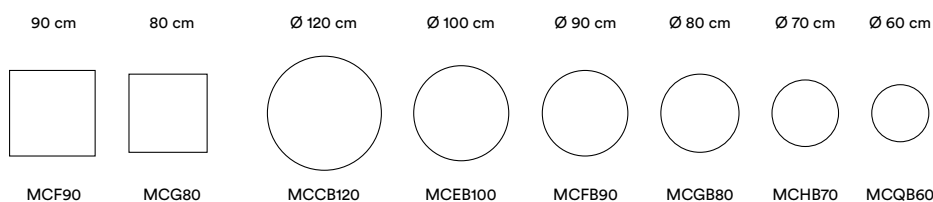
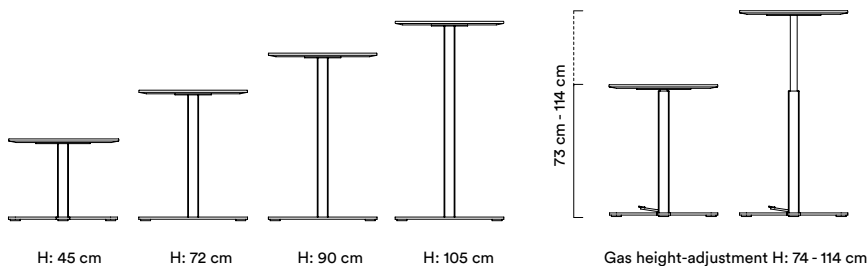
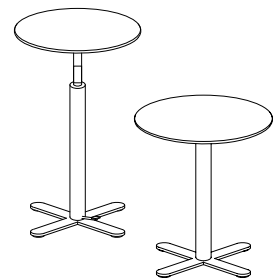

# Multi Speaker

EU ECOLABEL CERTIFIED

## Lectern

The Multi Speaker is ideal for use in conference rooms, larger meeting spaces, and classrooms. With its slightly sloping surface, the lectern allows the speaker to comfortably place notes or a laptop at an ideal standing working height. Multi Speaker is available in two fixed heights, as well as with gas height adjustment. The table comes in a wide range of surface finishes and colours.



### Frame and Tabletop

The frame of the Multi Speaker consists of an X-base and a 72 cm high column with a diameter of 60 mm.

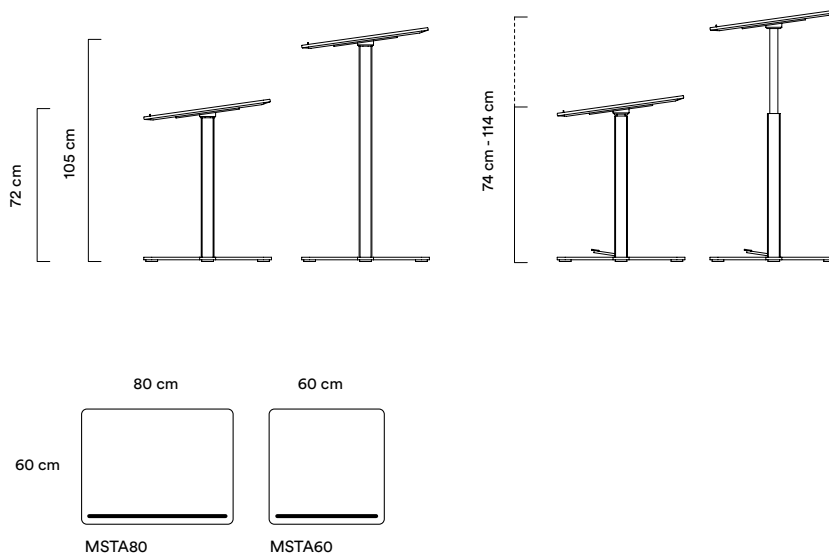

# Multi Table surfaces

## Tabletops for Multi Café and Multi Speaker

The tabletops are available in Laminate, Micro Laminate, Nano Laminate, Linoleum, and Veneer. Standard tabletops come with edges in lacquered MDF that match the surface. If painted edges are desired in colors matching the standard surfaces, this should be specified at the time of ordering, except for veneer and micro laminate surfaces. There may be slight variations in the veneer patterns.

### Linoleum



**Linoleum**  
Mushroom / Forbo 4176



**Linoleum**  
Ash / Forbo 4132



**Linoleum**  
Charcoal / Forbo 4166



**Linoleum**  
Nero / Forbo 4023



**Linoleum**  
Mauve / Forbo 4172



**Linoleum**  
Burgundy / Forbo 4154



**Linoleum**  
Pistachio / Forbo 4183



**Linoleum**  
Olive / Forbo 4184



**Linoleum**  
Walnut / Forbo 4003

### Laminate

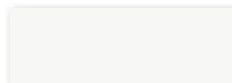

**Laminate** 38L Snow Silk

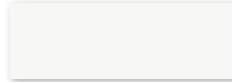

**Laminate** 38L Snow



**Laminate** 09L Nordic



**Laminate** 02L Fjord



**Laminate** 04L Anthracite



**Laminate** 157L Cumin



**Laminate** F3050L Cygnet



**Laminate** F8240L Liquid glass

### Micro Laminate



**Micro Laminate:** 38ML Snow



**Micro Laminate:** 02ML Fjord

### Nano Laminate



**Nano Laminate**  
0718N Clay



**Nano Laminate**  
0754N Blue Fes



**Nano Laminate**  
0720N Black



**Nano Laminate**  
0789N Rosso Namib

### Veneer



**Veneer** White Oak 131F



**Veneer** Nature Oak 62F



**Veneer** Black Oak 133F

# Multi Table frame

---

## Frame

Consists of a cross base and a round column Ø60 mm. The feet and column are available in powder-coated finishes. The feet come in chrome, and the column is 72 cm high in polished aluminium.

### Frame Colour Powder-Coated

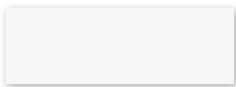

Powder Coat Snow 38



Powder Coat Black 05

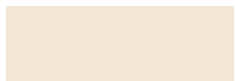

Powder Coat Beige15



Powder Coat Black Red 07



Powder Coat Shadow 147



Powder Coat Pine 136



Powder Coat Pomelo 140



Powder Coat Hokkaido 162

### Frame\* Polished Aluminium



Aluminium 43P

### Frame\* Chrome



Chrome Chrome 44C

\*Available at an additional cost.

Please note that printed colours may differ from the original colour.



# Panton Table

10 models / Design: Verner Panton



## Versatile Pedestal Tables

Montana is reintroducing the Panton Table, an iconic design by Verner Panton that reflects his clear, playful and uncompromising approach to form. The relaunch expands the original concept with new sizes, heights and surface options, increasing its versatility across private homes, cafés and collaborative workspaces. With its round, inviting tabletop, subtle detailing and broad colour palette, the Panton Table functions as a natural gathering point, offering a design that feels both timeless and precisely attuned to contemporary interiors.

### Technical Information

The Panton Table is designed for indoor use and features a powder-coated steel frame available in selected Montana colours, combined with a 19 mm MDF tabletop finished in laminate, nano laminate or linoleum. All models are delivered flat-packed (knock-down) for efficient transport and assembly. The table is available in multiple diameters and heights, including dining, café, coffee and bar table variants, and has a maximum load capacity of 30 kg evenly distributed. The Panton Table carries a five-year warranty and is expected to be available from Q1 2026.

# Panton Table overview

---

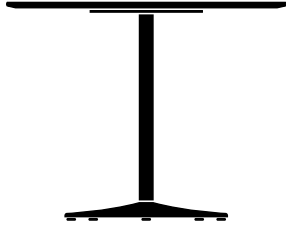

Panton Dining Table 244

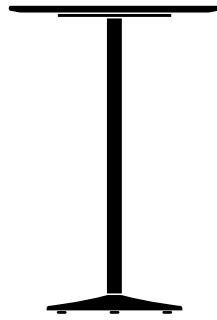

Panton Bar Table 244

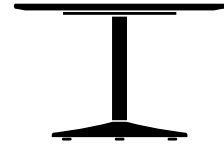

Panton Coffee Table 244



Surfaces 245

# Panton Table overview

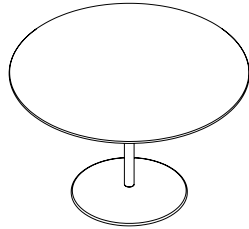

**Panton Dining Table**

H: 74 cm

Tables Ø120 and Ø100 cm with 5.5 cm tubes and Ø58 cm base.

Tables Ø75, Ø60 and 70 × 70 cm with 4.8 cm tubes and Ø48 cm base.

The frame is powder-coated.

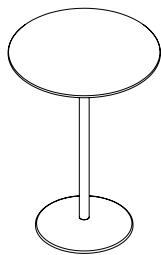
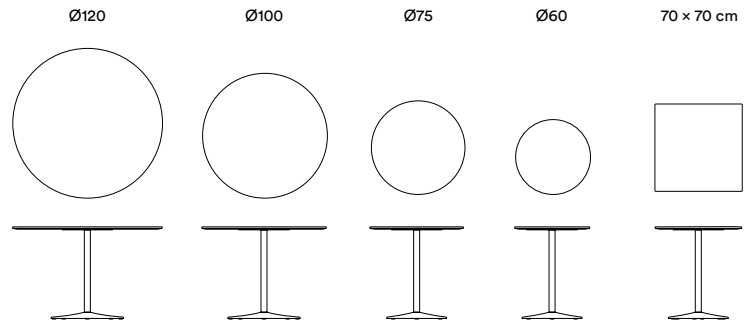

**Panton Bar Table**

H: 105 cm

4.8 cm tube and Ø48 cm base, powder-coated.

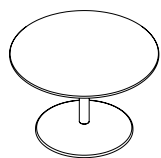
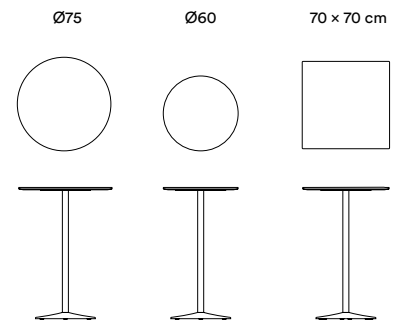

**Panton Coffee Table**

H: 45 cm

4.8 cm tube and Ø48 cm base, powder-coated.

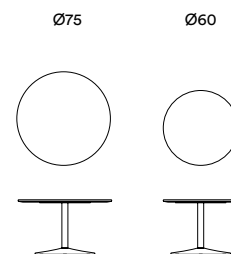

# Panton Table surfaces

## Materials

The frame features a trumpet-shaped base and column with a diameter of Ø42 mm, made from powder-coated steel in Snow and Black. Panton Table tabletops are available in laminate in Snow and Linoleum Nero / Forbo.

### Linoleum



**Linoleum**  
Mushroom / Forbo 4176



**Linoleum**  
Ash / Forbo 4132



**Linoleum**  
Charcoal / Forbo 4166

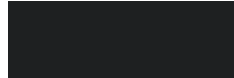

**Linoleum**  
Nero / Forbo 4023



**Linoleum**  
Mauve / Forbo 4172



**Linoleum**  
Burgundy / Forbo 4154

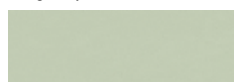

**Linoleum**  
Pistachio / Forbo 4183



**Linoleum**  
Olive / Forbo 4184



**Linoleum**  
Walnut / Forbo 4003

### Laminate\*

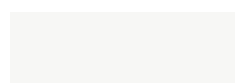

**Laminate 38L Snow Silk**

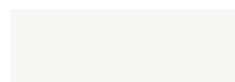

**Laminate 38L Snow**



**Laminate 09L Nordic**



**Laminate 02L Fjord**



**Laminate 04L Anthracite**



**Laminate 157L Cumin**



**Laminate F3050L Cygnet**



**Laminate F8240L Liquid glass**

### Nano Laminate\*



**Nano Laminate 0718N Clay**



**Nano Laminate 0754N Blue Fes**



**Nano Laminate 0720N Black**



**Nano Laminate 0789N Rosso Namib**

### Frame Colour Powder-Coated

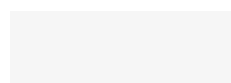

**Powder Coat 38 Snow**



**Powder Coat 05 Black**

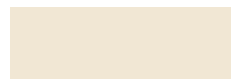

**Powder Coat 15 Beige**



**Powder Coat 07 Black Red**



**Powder Coat 147 Shadow**



**Powder Coat 136 Pine**



**Powder Coat 140 Pomelo**



**Powder Coat 162 Hokkaido**



# Kevi Table

Design: Jørgen Rasmussen



## Lounge and Café Table

The Kevi tables are designed with the same simple and functional principles as the Kevi chair series. The table's minimalist design reflects a timeless aesthetic where form and function go hand in hand. Constructed with a chrome-plated frame, the table ensures stability and durability, complemented by a surface in black stain that adds a modern and sleek expression. The Kevi table is a versatile lounge and café table that fits into both private and public spaces, where simplicity and quality are at the forefront.

### Technical Information

The Kevi table is delivered in a fixed configuration with a chrome frame and a tabletop in black-stained ash. It is available in two sizes with a diameter of Ø90 cm and a height of either 36 cm or 72 cm. Load 80 kg evenly distributed.

# Kevi Table overview

---



Lounge table

248

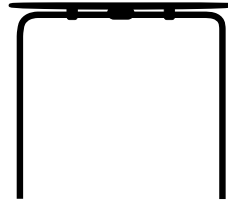

Café table

248



Surfaces

249

# Kevi Table

---

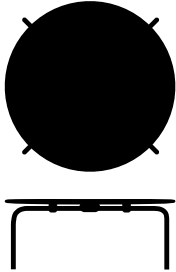

Kevi 2001      Ø90 x H 36 - (Frame: Ø101.5 cm)

E2001

**Frame**  
22 mm tube, chrome or powder-coated black.

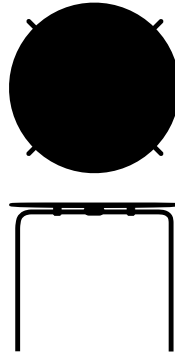

Kevi 2011      Ø90 x H 72 - (Frame: Ø101.5 cm)

E2011

**Frame**  
22 mm tube, chrome or powder-coated black.

# Kevi Table surfaces

---

## Table Surfaces

Table surfaces are available in veneer in black and natural finishes.

## Frame

22 mm tube, chrome or powder-coated black.

### Powder-Coated (varnished)



Powder Coat Nature 62F

### Frame Colour Powder-Coated



Powder Coat Black 05

### Frame Colour Chrome



Chrome Chrome 44C



Powder Coat  
Black Veneer 05F



# Moser Table

Design: Kasper Mose



## Folding Table

Moser is a versatile series of folding tables available in various sizes, both round and rectangular, as well as in multiple heights, colours, and finishes. Originally designed for the contract market, the Moser series offers a functional solution for environments where flexibility and variation in size and height are crucial.

The table's soft, rounded yet clear design makes it easy to integrate into a wide range of spaces. Its practical chair hanging feature, folding function, and the accompanying trolley that can hold eight folded tables make Moser ideal for busy environments where daily handling and storage need to be simple and efficient.

### Technical Information

The Moser table is available in 10 rectangular sizes and 3 heights: dining height (H 74 cm), counter height (H 90 cm), and bar height (H 105 cm). The Moser table with a round top comes in Ø120 and Ø140, both in H 74 cm. All tables are equipped with a folding mechanism, and the tables fold by lifting them upright and releasing the handle that locks the frame. The rectangular tables with slanted ends have a crossbar that can be used as a footrest on counter and bar tables. The Moser trolley has space for 8 tables. All tables are delivered as knock-down (flat-pack).

# Moser Table overview

---

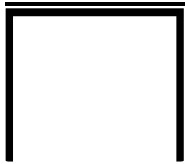

**Straight Legs**

252

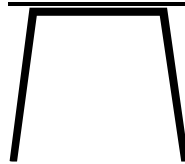

**Slanted Legs**

252

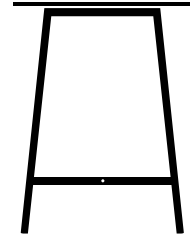

**Counter, Slanted Legs**

252

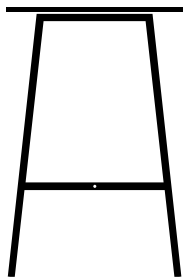

**Bar, Slanted Legs**

252

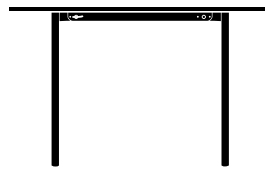

**Round, Straight Legs**

252

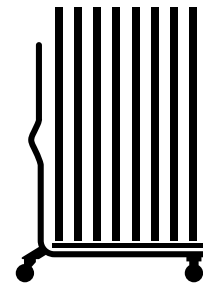

**Components**

256



**Surfaces**

257

# Moser Table

---

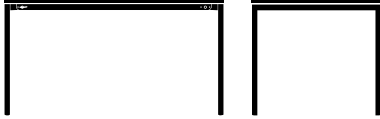

## Straight Legs

### Frame

Rectangular steel profile 3 × 4 cm with a rounding on the side of the profile that matches the radius of the table's corners.

### Certificates and Test

EN 15372

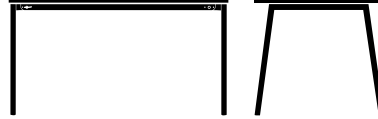

## Slanted legs

### Frame

Rectangular steel profile 3 × 4 cm with a rounding on the side of the profile that matches the radius of the table's corners.

### Certificates and Test

EN 15372

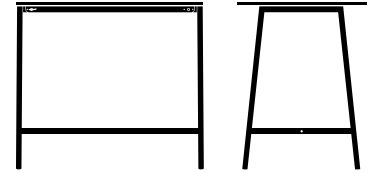

## Counter, slanted legs

### Frame

Rectangular steel profile 3 × 4 cm with a rounding on the side of the profile that matches the radius of the table's corners.

### Certificates and Test

EN 15372

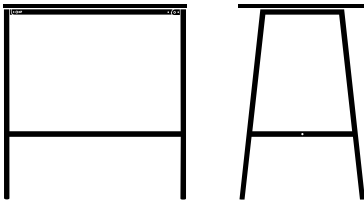

## Counter, slanted legs

### Frame

Rectangular steel profile 3 × 4 cm with a rounding on the side of the profile that matches the radius of the table top corners.

### Certificates and Test

EN 15372



## Round, straight legs

### Frame

Rectangular steel profile 3 × 4 cm with rounding on one side of the profile.

### Certificates and Test

EN 15372

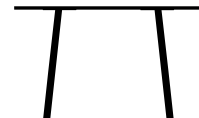

## Round, straight legs

### Frame

Cannot be folded

### Certificates and Test

EN 15372



## Moser Table Straight Legs

Available in 10 sizes, with straight legs and feet in the form of floor glides and castors for easier handling during setup and folding. Tables in depths of 90 and 100 cm feature reinforced frames and cannot use the transport trolley due to their size and weight. Other sizes available upon request.

**Certificates and Test:** EN 15372.

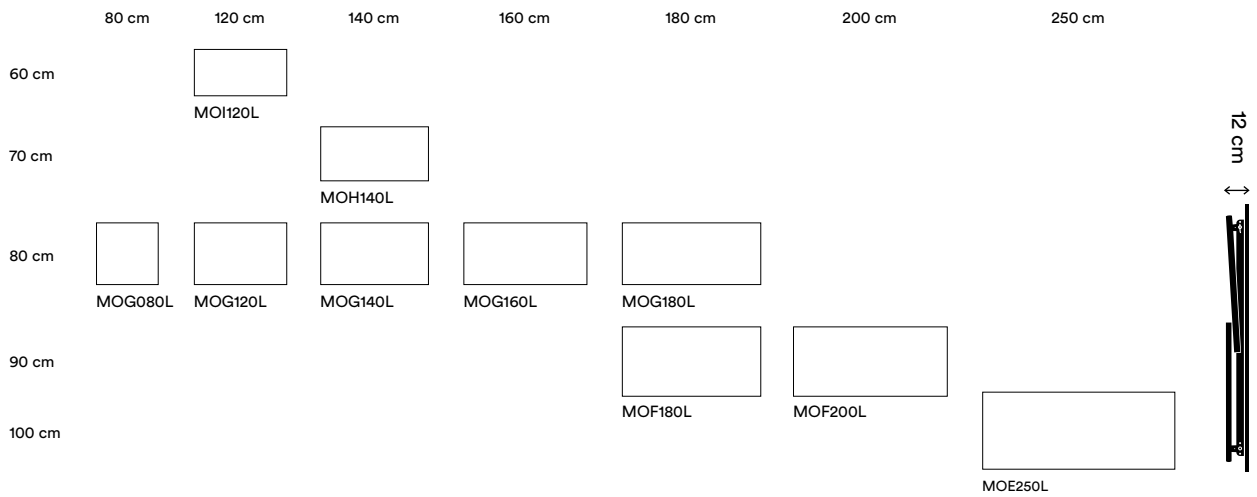

## Moser Table Angled Legs

Available in 10 sizes, with angled legs and feet in the form of floor glides and castors for easier handling during setup and folding. Tables with a depth of 90 and 100 cm have a reinforced frame and cannot be used with the transport trolley due to their size and weight. Other sizes are available upon request.

**Certificates and Test:** EN 15372.

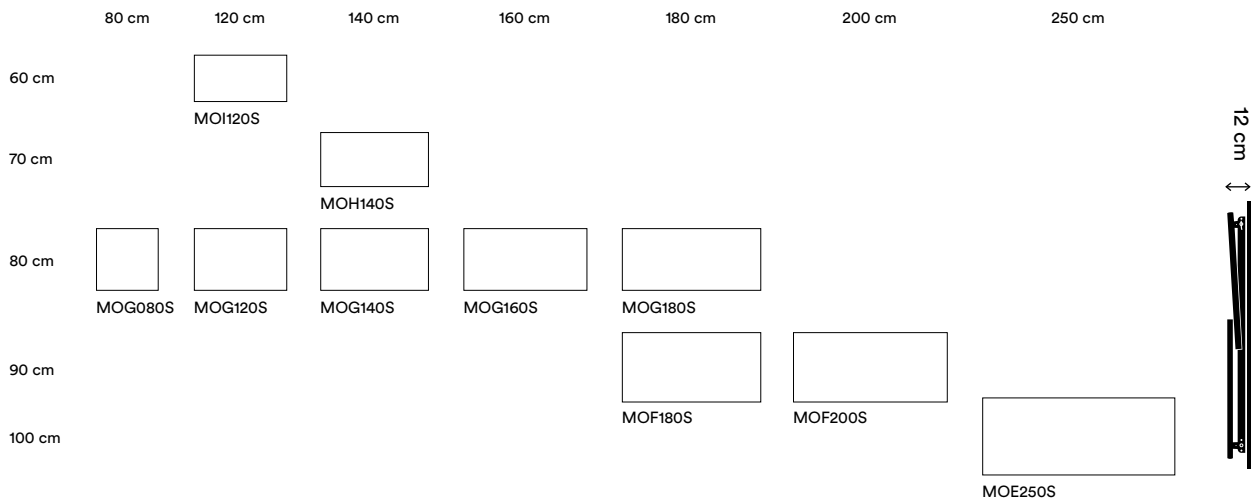

### Moser Table Counter & Bar

4-legged table with angled legs, reinforced sides, and a cross footrest. The counter table is 90 cm high and the bar table is 105 cm high, both are delivered with adjustable feet. Tables in other sizes are available upon request.

**Certificates and Test:** EN 15372.

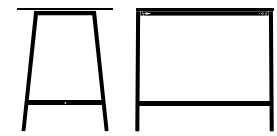
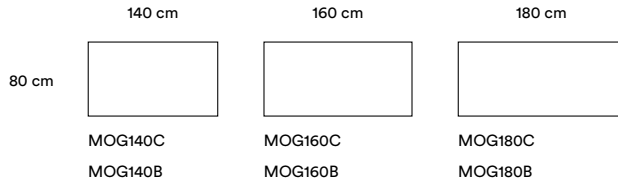

Counter

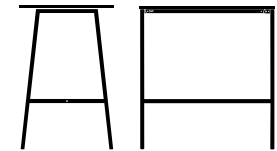

Bar

### Moser Table Round with Straight Legs

Round 4-legged table with straight legs, featuring adjustable feet and gliders. Tables in other sizes are available upon request.

**Certificates and Test:** EN 15372.

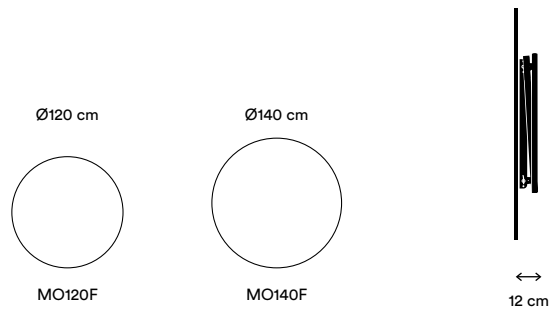

### Moser Table Round with Slanted Legs

Round 4-legged table with slanted legs, featuring adjustable feet and gliders. The frame is fixed and not foldable.

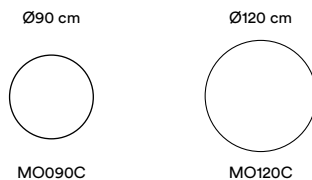

# Moser Table components

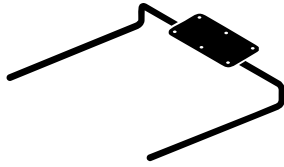

## Single Suspension

<b>OPCHS</b>	
<b>Model</b>	MOI120L & MOI120S
<b>Material</b>	Steel

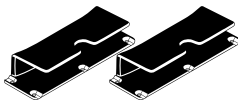

## Suspension Kevi

<b>OPKE</b>	
<b>Model</b>	Not available for round tables
<b>Material</b>	Black plastic

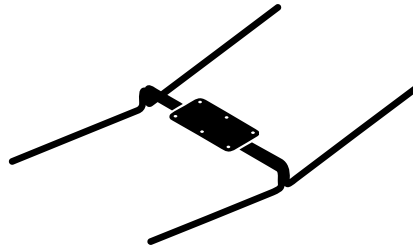

## Double Suspension

<b>OPCHD</b>	
<b>Model</b>	Not available for round tables
<b>Material</b>	Steel



## Linking Brackets

<b>MOCONCT1</b>	
<b>Model</b>	Not available for round tables
<b>Material</b>	Steel

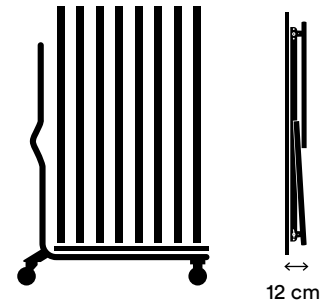

## Trolley

<b>MOTROL</b>	
<b>Model</b>	All folding tables*
<b>Dimensions</b>	W 52 x H 173 x D 136 cm
<b>Quantity</b>	8 tables
<b>Material</b>	2 fixed and 2 movable castors

Total height of stacking trolley including folding tables:

120/140 cm	= H 173 cm
160 cm	= H 185 cm
180 cm	= H 205 cm

Total width depends on the table's width  
Folding height of the table is 12 cm.

Depth of the folded table is 12 cm

\*Folding tables in Ø120 cm and Ø140 cm cannot be used with the Moser trolley, but are compatible with standard trolleys available on the market.

# Moser Table surfaces

## Surfaces

The tabletop is made from 16 mm particleboard with Laminat, Linoleum, or Nano laminate and ABS edges.

## Frame

Moser Table is available in rectangular shapes in various sizes and round tabletops in two sizes. The frame is powder-coated as standard in eight different colours and also available in chrome. All tables are shipped knock-down, assembled, and with a folding mechanism.

MO140F is not available in Laminat and Nano laminate.

### Linoleum



**Linoleum**  
Mushroom / Forbo 4176



**Linoleum**  
Ash / Forbo 4132



**Linoleum**  
Charcoal / Forbo 4166



**Linoleum**  
Nero / Forbo 4023



**Linoleum**  
Mauve / Forbo 4172



**Linoleum**  
Burgundy / Forbo 4154



**Linoleum**  
Pistachio / Forbo 4183



**Linoleum**  
Olive / Forbo 4184



**Linoleum**  
Walnut / Forbo 4003

### Laminat\*

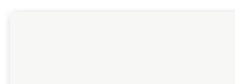

**Laminat** 38L Snow Silk

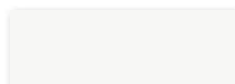

**Laminat** 38L Snow

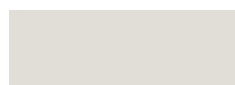

**Laminat** 09L Nordic



**Laminat** 02L Fjord



**Laminat** 04L Anthracite



**Laminat** 157L Cumin



**Laminat** F3050L Cygnet



**Laminat** F8240L Liquid glass

### Nano Laminat\*



**Nano Laminat**  
0718N Clay



**Nano Laminat**  
0754N Blue Fes



**Nano Laminat**  
0720N Black



**Nano Laminat**  
0789N Rosso Namib

### Frame Colour Powder-Coated

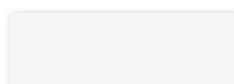

**Powder Coat** Snow 38



**Powder Coat** Black 05

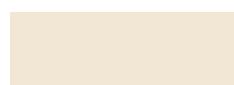

**Powder Coat** Beige15



**Powder Coat** Black Red 07



**Powder Coat** Shadow 147



**Powder Coat** Pine 136

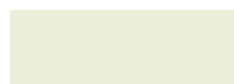

**Powder Coat** Pomelo 140



**Powder Coat** Hokkaido 162

### Frame Colour Chrome



**Chrome** Chrome 44C

\* MO140F is not available in Laminat and Nano laminate.

Please note that printed colours may differ from the original colour.



# Foldit

30 models / Design: Erik Magnussen

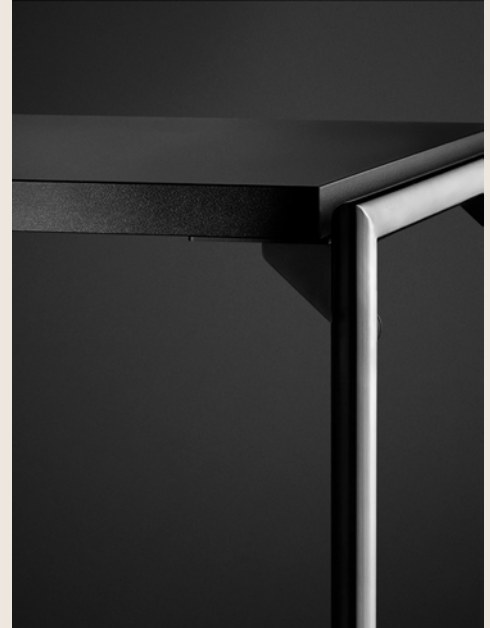

## Folding Table

Foldit is an elegant and functional folding table designed by Erik Magnussen. Foldit does not look like a typical folding table, but retains the benefits of a folding table; it can be unfolded or packed away in no time without compromising on stability or functionality. The tables easily connect using the included linking brackets, making them ideal for larger setups, such as conferences, meetings, and training sessions. The table can be easily stored on a matching trolley that holds up to 10 tables.

### Technical Information

The Foldit table comes in various sizes – choose from widths of 60, 70, and 80 cm, with a height of 73 cm and lengths of 128, 140, 160, 180, and 200 cm. The four-legged table features two castors and two adjustable feet.

### Accessories and Components:

Various accessories and components are available for the Foldit table, such as panels, corner plates, linking brackets, and a transport trolley.

# Foldit overview

---



**Table**

260



**Suspension Panel**

260

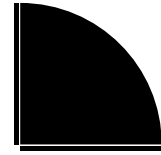

**Components**

261



**Surfaces**

262

## Foldit – Folding Table

The Foldit table is available in various sizes – choose from widths of 60, 70, and 80 cm, with a height of 73 cm and lengths of 128, 140, 160, 180, and 200 cm. The four-legged table comes with two wheels and two adjustable feet.

### Table sizes

	128 cm	140 cm	160 cm	180 cm	200 cm	
60 cm						 11 cm
	FOLDIT606	FOLDIT607	FOLDIT608	FOLDIT609	FOLDIT610	
70 cm						
	FOLDIT621	FOLDIT622	FOLDIT623	FOLDIT624	FOLDIT625	
80 cm						
	FOLDIT611	FOLDIT612	FOLDIT613	FOLDIT614	FOLDIT615	

### Suspension panel sizes

	128 cm	140 cm	160 cm	180 cm	200 cm
60 cm					
	FOLDIT656	FOLDIT657	FOLDIT658	FOLDIT659	FOLDIT660
70 cm					
	FOLDIT671	FOLDIT672	FOLDIT673	FOLDIT674	FOLDIT675
80 cm					
	FOLDIT661	FOLDIT662	FOLDIT663	FOLDIT664	FOLDIT665

# Foldit components



## Foldit Front Panel

Height 40 cm

<b>FOLDIT641</b>	128 cm
<b>FOLDIT642</b>	140 cm
<b>FOLDIT643</b>	160 cm
<b>FOLDIT644</b>	180 cm
<b>FOLDIT645</b>	200 cm

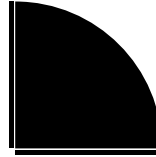

## Foldit Corner Plate

Rounded corners, including a 'table connector'.

<b>FOLDIT682</b>	60 x 60 cm
<b>FOLDIT685</b>	70 x 70 cm
<b>FOLDIT683</b>	80 x 80 cm

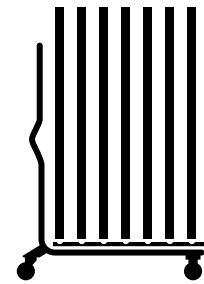

11 cm

## Trolley

<b>FOLDIT699</b>	
<b>Dimensions</b>	H 173 x D 136 x W 52
<b>Quantity</b>	10 tables
<b>Material</b>	2 fixed and 2 castors.

**Total height of the stacking trolley including tables:**

<b>128 cm</b>	= 173 cm
<b>140 cm</b>	= 177 cm
<b>160 cm</b>	= 197 cm
<b>180 cm</b>	= 217 cm
<b>200 cm</b>	= 237 cm

Total width depends on the width of the tables.



## Linking Bracket

Width 7 cm

<b>FOLDIT692</b>	60 cm
<b>FOLDIT695</b>	70 cm
<b>FOLDIT693</b>	80 cm

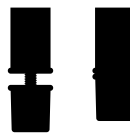

## Foldit adjustable feet / castors

Adjustable feet or castors, 2 pieces

<b>FOLDIT697</b>	2 pcs. shoes
<b>FOLDIT698</b>	2 pcs. castors
<b>Material</b>	Plastic

# Foldit surfaces

---

## Materials

### Tabletop

The tabletop is available in Oak, Laminate, and Linoleum.

### Base

Chrome-plated steel in Ø32 mm tube.

#### Laminate



Laminate 801L EB White



Laminate 803L EB Grey



Laminate 805L EB Black

#### Veneer (lakeret)



Veneer Black Lasur



Veneer Oak

#### Linoleum



Linoleum Nero / Forbo 4023

#### Frame Colour Chrome



Chrome Chrome 44C



# Djob Table

10 models / Design: Arne Jacobsen



## School or Canteen Table

Designed by Arne Jacobsen in 1971 for offices and meeting rooms in Denmark's National Bank, the Djob Table features a sleek and simple design, making it suitable for various spaces including as a work, meeting, school, or dining table. Djob Table is available in a wide range of tabletop sizes, finishes, and colours.

### Technical Information

Djob Table comes in 10 standard tabletop sizes with a fixed height of 72 cm. Custom sizes are available for tabletops ranging from L60-220 cm and W60-120 cm. The table can support a maximum load of 120 kg, evenly distributed across the tabletop.

## Djob Table

The Djob Table is available as a work, meeting, and side table. The dimensions shown in the drawings indicate the tabletop, including the frame. The table can support a maximum load of 80 kg, evenly distributed. The dimensions in the drawings refer to the tabletop, including the frame.

### Custom Sizes

Djob Table work and meeting tables are available in custom sizes and shapes, with depth ranging from 600 to 1200 mm and length from 600 to 2200 mm, tailored to customer specifications.

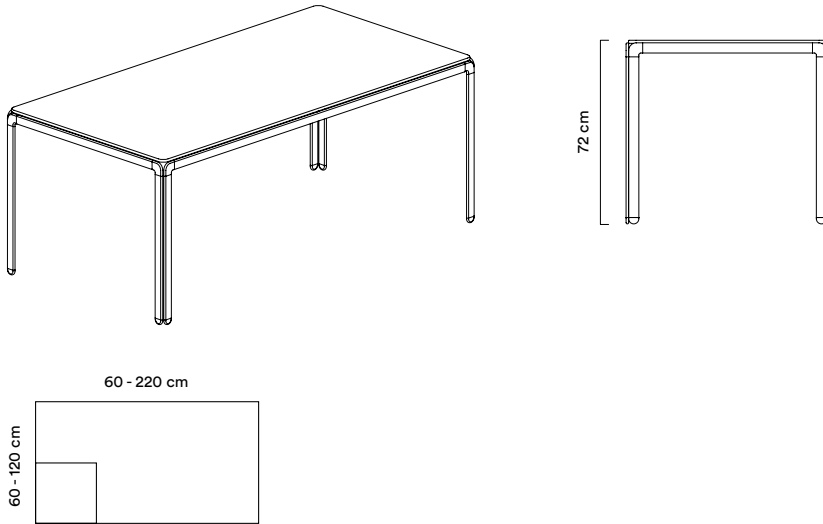

### Standard sizes

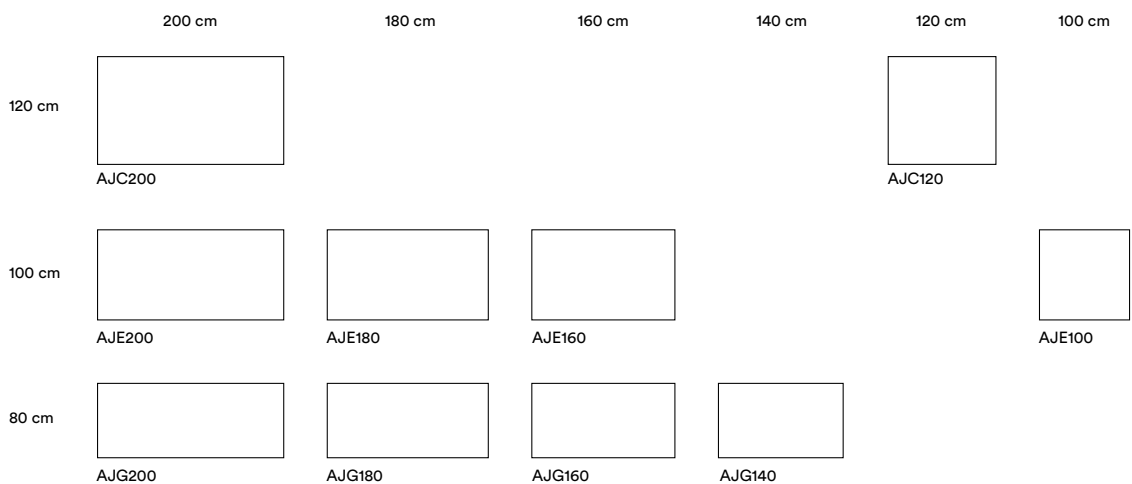

# Djob Table surfaces

## Frame

The Djob Table frame is made from anodised aluminium with corners and feet made of zinc-aluminium alloy, which are then matte chrome-plated. The frame, corners, and feet can be optionally lacquered in the colours 38 Snow and 05 Black for an additional cost.

## Tabletops

The tabletops are available in Laminat, Silk Laminat, Microlaminat, Linoleum, and Veneer. As standard, the tabletops come with edges in lacquered MDF, matching the surface. When ordering, you can specify if you prefer painted edges in colours that match the standard surfaces—except for veneer and microlaminat surfaces. Djob Table is available as work, meeting, and side tables. The table can support a load of up to 80 kg, evenly distributed.

### Micro Laminat

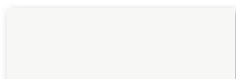

Micro Laminat: 38ML Snow



Micro Laminat: 02ML Fjord

### Laminat\*

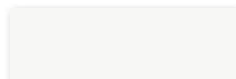

Laminat 38L Snow Silk

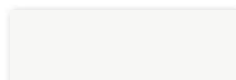

Laminat 38L Snow



Laminat 09L Nordic



Laminat 02L Fjord



Laminat 04L Anthracite

### Linoleum

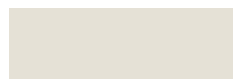

Linoleum  
Mushroom / Forbo 4176



Linoleum  
Ash / Forbo 4132



Linoleum  
Charcoal / Forbo 4166



Linoleum  
Nero / Forbo 4023



Linoleum  
Mauve / Forbo 4172



Linoleum  
Burgundy / Forbo 4154

### Veneer



Veneer White Oak 131F



Veneer Black Oak 133F

### Frame Colour Aluminium



Eloxeret aluminium  
Matforkromet

### Frame Colour Powder-Coated

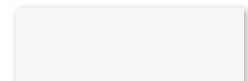

Powder Coat 38 Snow



Powder Coat 05 Black



# HiLow Table

Design: Peter J. Lassen og Joakim Lassen



## Desk Series with Height Adjustable Function

HiLow is a series of electric height-adjustable desks designed to encourage both sitting and standing office work. The tabletop's edge profile features the classic chamfered Montana profile. The desk's depth accommodates ergonomic guidelines, providing ample space for both keyboard and monitor, arm support, and proper viewing distance. The HiLow series frame is designed to allow plenty of legroom. Components for HiLow desks can be optionally mounted in the tabletop.

### Technical Information

Many HiLow desks meet EU and Occupational Health and Safety standards for a flexible and ergonomic workplace. Choose from a wide range of desk components, such as cable management, wireless mobile charger, power outlets, lamp holders, permanently mounted waste bins, partition/privacy screens, and pencil trays, ensuring the desk meets your exact functional needs.

# HiLow Table overview

---

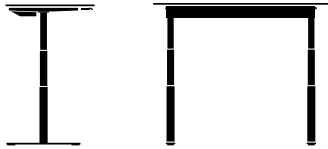

HiLow 2 268



HiLow Double 272

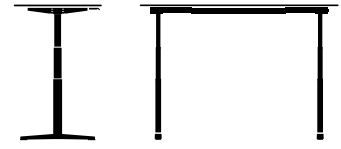

HiLow 3274 250

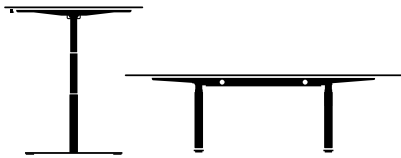

HiLow Conference 276



HiLow Components 278



Surfaces 284

# HiLow 2

EU ECOLABEL CERTIFIED

## Height-Adjustable Desk

HiLow 2 is an electric height-adjustable desk that can be adjusted for both sitting and standing work. The tabletop's edge features the classic chamfered Montana profile, and the depth offers ample space for the keyboard, monitor, arm support, and optimal viewing distance. HiLow components can be optionally mounted in the tabletop. The frame is designed to allow plenty of legroom.

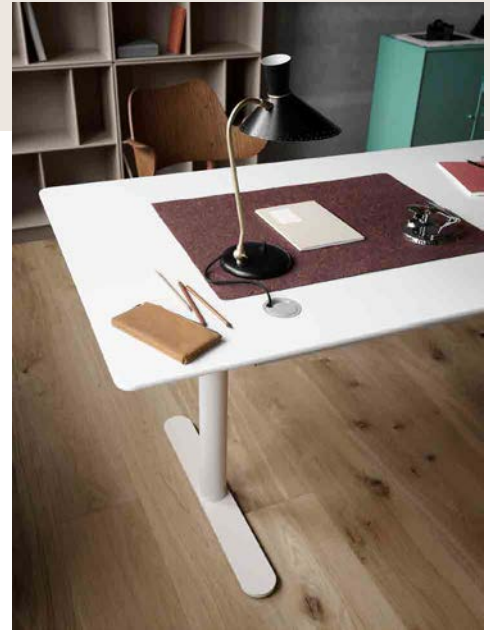

---

### Technical Information

HiLow 2 is available in 8 standard sizes. It is also possible to choose a sliding top and a polygonal Wewerka version (the last three drawings below). The electronic height-adjustable desks can be equipped with cable management. HiLow 2 desks can support up to 120 kg evenly distributed across the tabletop.

## HiLow 2 – Frame and Tabletops

The work desks feature a round leg profile and come with electric height adjustment, offering the option of two different frames. The DL11 is a premium frame with a closed cable tray, while the DFR frame features an open cable tray. Both frames are made from powder-coated steel and are available as standard in the colors 43P Aluminium, 38 Snow, and 05 Black. The DL11 frame is available, for an additional cost, in the colors Beige, Black Red, Shadow, Pine, and Chrome. The tabletops are available in micro laminate, laminate, silk laminate, nano laminate, linoleum, and veneer. The tabletops come as standard with edges in lacquered MDF that matches the surface. Please specify at the time of order if you wish for painted edges in colors that correspond to the standard surfaces—excluding veneer surfaces and micro laminate.

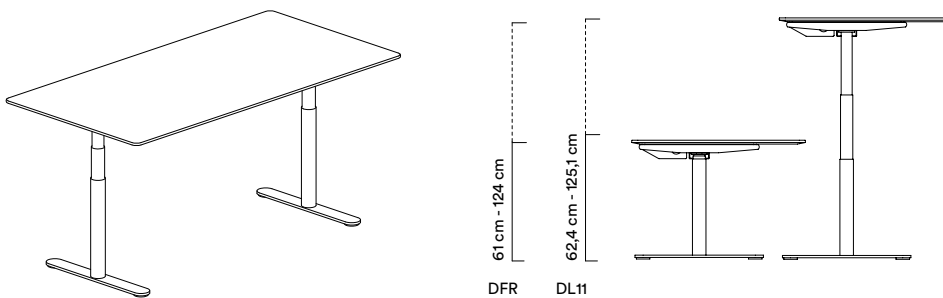

### DL11

The tabletops are available in custom sizes:

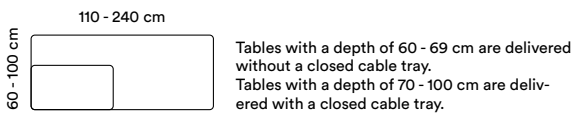

### DFR

The tabletops are available in custom sizes:

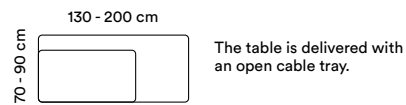

### DL11 and DFR

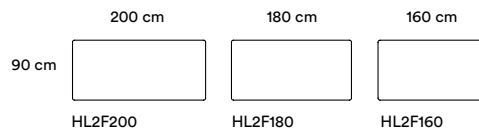
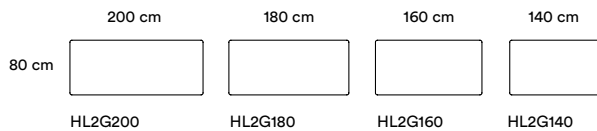

### DL11

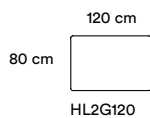

### Wewerka Table

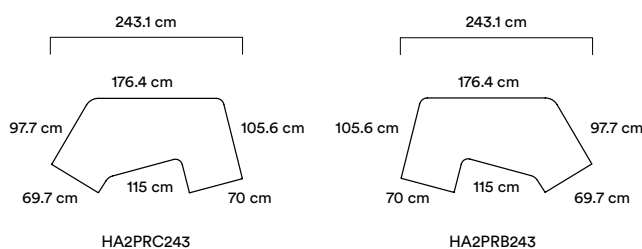

### 120° Corner Desk (also known as a winged desk)

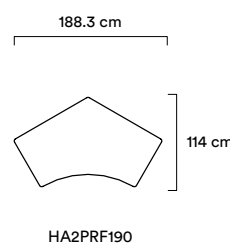

## Cable management and steel control buttons in tables

The drawings show possible placements for cable grommets and steel control buttons. Cable grommets, lamp holders, and powerdots have 7 possible placement positions. Specify placement when ordering, for example, 1V, which indicates the furthest left position. Cable grommets in positions 3H/3V are not possible in tables with a width of 1200 to 1399 mm. The steel control button placement is on the left and right, shown as two dots on the drawing; however, HA2PRC243 and HA2PRB243 only have one placement option.

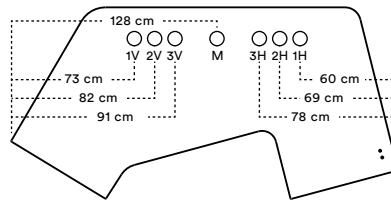
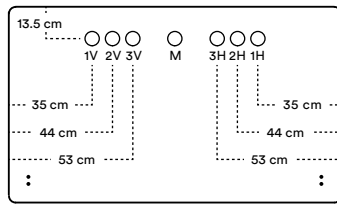

HA2PRC243

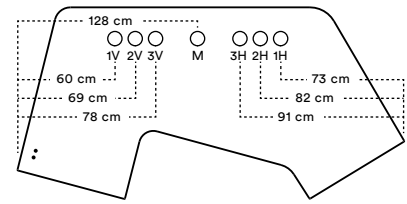

HA2PRB243

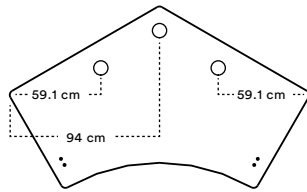

## HiLow Slidetop Tables

Slidetop tables are only available with the DL11 frame. Slidetop tables allow access to the cable tray through the tabletop. The tabletop is divided into two parts: a fixed part and a movable part. The movable part is the front edge of the tabletop. This part is manually activated by a firm pull, and the panel opens over the cable tray. It is not possible to select cable grommets, powerdots, or power outlets for slidetop tables.

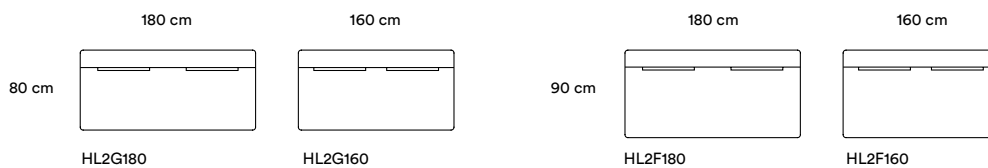



# HiLow Double

EU ECOLABEL CERTIFIED

## Double Standing Desk

The HiLow Double features a single frame with two tabletops, each having individual height adjustment functions. The desk can be equipped with acoustic panels made from padded sound-absorbing material or lacquered MDF, which separate the two workstations.



---

### Technical Information

The HiLow Double is available in 4 standard sizes. It comes with tabletops in widths of 180, 160, and 140 cm, all with a depth of 80 cm. The desk's height adjustment range is from 61.9 cm to 125.4 cm. Maximum load: 120 kg, evenly distributed across the tabletop.



## HiLow Double – Frame and Tabletops

The HiLow Double desk comes with tabletops in widths of 180, 160, and 140 cm, all with a depth of 80 cm. The desk's height adjustment range spans from 61.9 cm to 125.4 cm. Tabletops are available in micro laminate, laminate, silk laminate, nano laminate, linoleum, and veneer. As standard, the tabletops come with edges in lacquered MDF to match the surface. If desired, painted edges in colours matching the standard surfaces (except veneer and micro laminate) can be specified when ordering.

The frame is available in powder-coated finishes of 43P Aluminium, 38 Snow, or 05 Black.

## Privacy Screens

The gap between the two tabletops is 9 cm, providing sufficient space for screen mounting. The screens are available either in 12 mm MDF in all Montana lacquer colours or with an acoustic, padded screen from Götessons. The height of the screens from the floor is 126 cm.

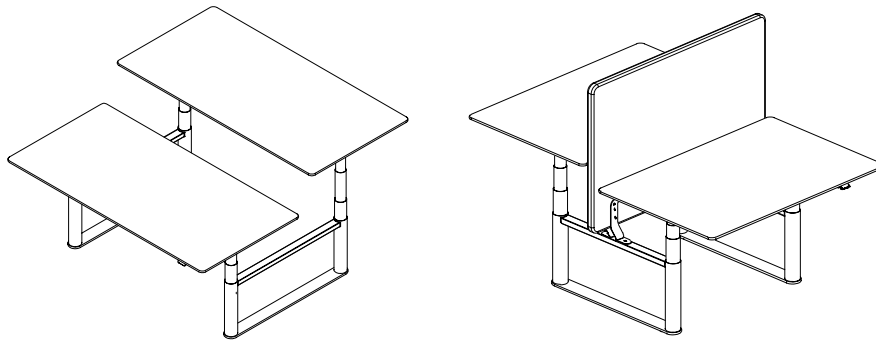

## Table Sizes

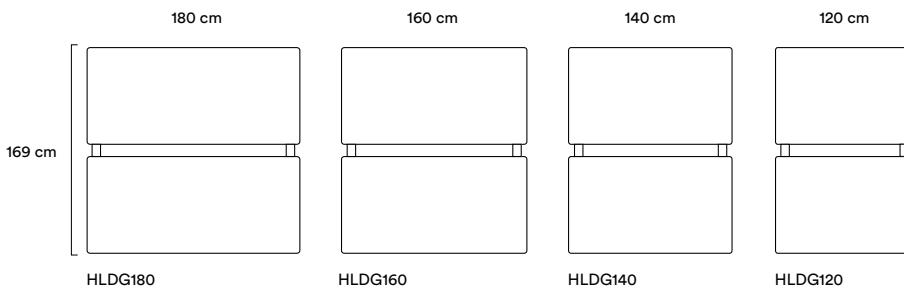

## Tabletops are available in custom sizes:

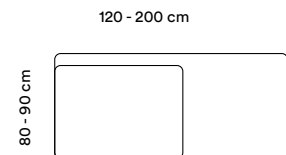

## Cable Management and Steel Control Switches in Tables

The drawings show possible positions for cable grommets and steel control switches. Cable grommets, lamp holders, and powerdots have 2x7 available positions. Specify the placement when ordering, for example, 1D1V, which indicates the outermost position to the left. The steel control switch placement is on the left and right, represented by two dots on the drawing.

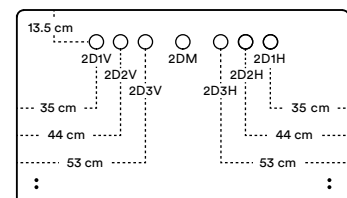
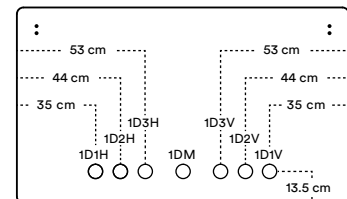

# HiLow 3

EU ECOLABEL CERTIFIED

## Height-adjustable Desk

The HiLow 3 desk features a clean design and is a versatile desk for office environments or home offices. The HiLow 3 frame has a square leg profile and is available in multiple sizes, with a foot made from polyamide PA6 30% glass (recycled material). The tabletop has Montana's classic rounded profile, although the smallest size has straight edges.



---

### Technical Information

HiLow 3 is available in 7 standard sizes. The desk has an electronic height adjustment range from 64 cm to 129 cm and square legs. HiLow 3 is delivered without a cable tray, but one can be purchased as an option. The desk can support up to 120 kg evenly distributed across the tabletop.



## HiLow 3 – Frame and Tabletops

HiLow 3 work desks are available with electric height adjustment and a square profile. The frame is made from powder-coated steel, and the foot is cast from plastic. The frame and feet are standard in powder-coated 43P Aluminium, 38 Snow, and 05 Black.

A cable tray is available as an optional addition.

The tabletops are available in micro laminate, laminate, silk laminate, nano laminate, linoleum, and veneer. The tabletops come as standard with MDF edges that match the surface. If desired, the edges can be painted in colours that match the standard finishes, except for veneer and micro laminate.

HiLow 3 can support up to 120 kg evenly distributed across the tabletop. The tabletops feature bevelled edges on all sides, except for the HLO3H120 model, which has straight edges.

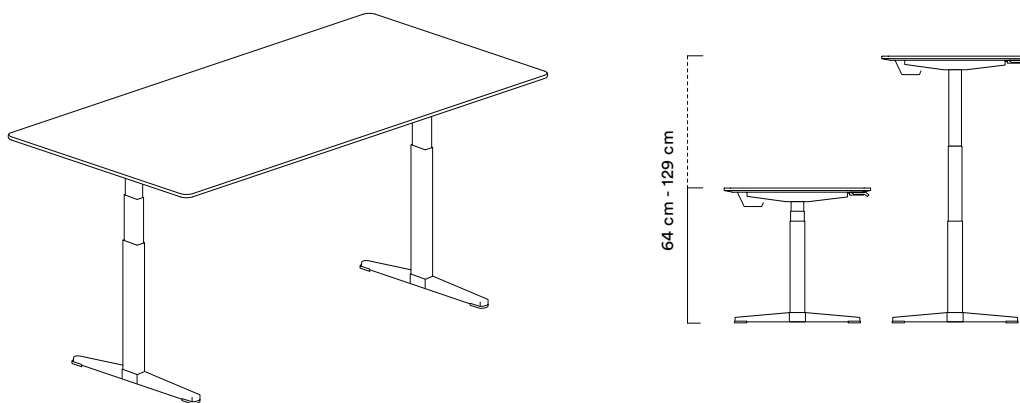

### Table Sizes

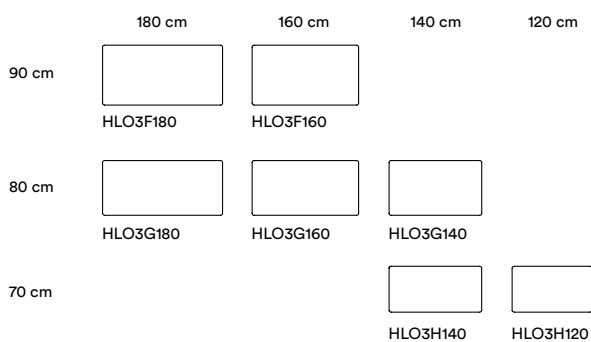

### Table Tops in Special Sizes

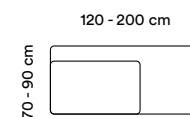

### Cable Routing and Steel Control Switches in Desks

Drawings indicate possible locations for cable routing and steel control switches. Cable routes, lamp holders, and powerdots have 7 placement options. Specify the placement when ordering, for example, 1V, which indicates the far-left placement. The steel control switch placement is available on both left and right sides, shown as two dots on the drawing.

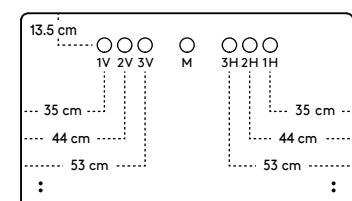

# HiLow Conference

EU ECOLABEL CERTIFIED

## Height-adjustable Conference Table

With HiLow Conference, there is the possibility to hold meetings in both standing and sitting positions. The tables are available with both height-adjustable functions and fixed legs and can be used as conference, meeting, or workshop tables. Power outlets make it possible to place electrical and PDS sockets so that meeting participants can connect to the network. The frame is designed to provide free legroom at all points.



### Technical Information

HiLow Conference is available in 4 sizes. The conference tables are available with electronic height adjustment and manual fixed adjustment.

### HiLow Conference – Frame

The conference tables are available with either electric height adjustment or fixed height at 74 cm. The feet and tabletop are powder-coated as standard.

The tabletops come in laminate, silk laminate, nano laminate, linoleum, and veneer. The edges of the tabletops are standard with lacquered MDF that matches the surface. If desired, you can specify painted edges in colors that match the standard surfaces, except for veneer surfaces.

Frames with DL11 columns are available in powder-coated 43P Aluminium, 38 Snow, or 05 Black, and for an additional cost, in the colors Beige, Black Red, Shadow, Pine, and Chrome.

Frames with Fixed columns are available in powder-coated 43P Aluminium, 38 Snow, or 05 Black, and for an additional cost, in Chrome.

### HiLow Conference – Two Tablets

The HiLow Conference L: 400 cm with two tablets has three leg profiles.

The HiLow Conference L: 320 cm with two tablets has two leg profiles.

### HiLow Conference – One Tablet

The HiLow Conference L: 240 cm and 200 cm with one tablet have two leg profiles.

### HiLow Conference Custom Sizes

An additional charge applies for custom-sized conference tables. These are made to customer-specific dimensions and shapes. Depth: 90 - 120 cm, Length: 200 - 400 cm. For pricing on custom sizes, please contact Montana.

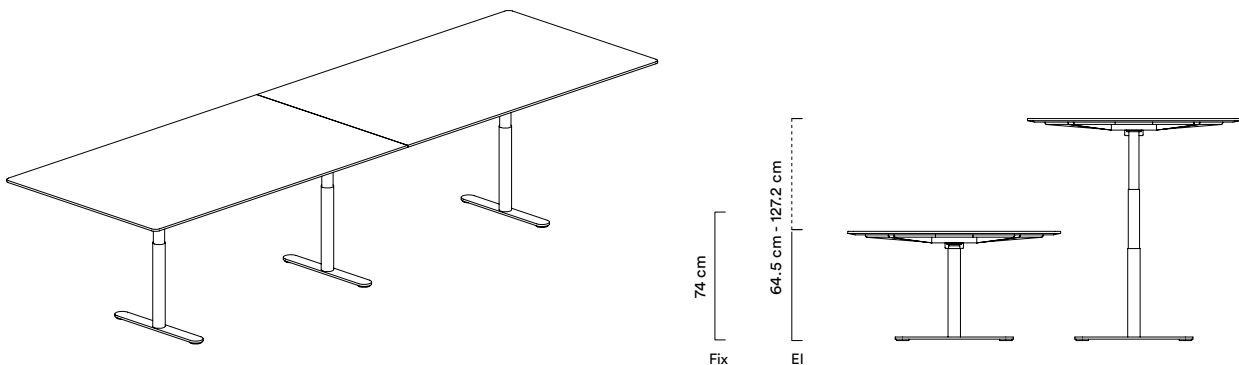

### Table Sizes

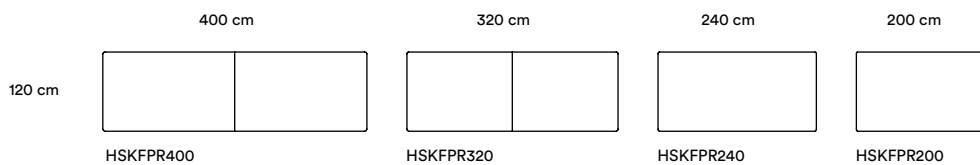

### Table Tops in Special Sizes

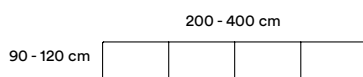

# HiLow components

EU ECOLABEL CERTIFIED

## Table Components for HiLow

The HiLow table series is one of Montana's most popular series and is designed to promote a healthy working posture through adjustable functions. The HiLow series includes various components that allow for customization of the table to individual preferences.

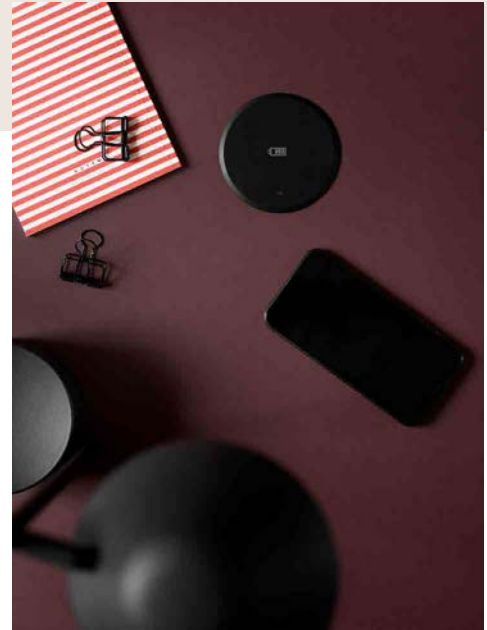

### Technical Information

**The tabletops** come in various sizes and shapes, ensuring an optimal working surface.

**Adjustable frames** that allow the user to switch between sitting and standing work. The frame is available with an electric height adjustment function for maximum flexibility.

**Cable management** in the form of cable trays and cable openings ensures a neat and organized workspace without loose cables.

**Screen dividers** for sound absorption and visual separation, creating a more focused working environment.

**Accessories** such as integrated drawers, lighting, and mounts for waste bins and CPU holders, further enhancing the functionality of the workspace.

# HiLow components



## Cable Management

**KABELA:** Ø75 mm including milling. Inner diameter Ø65 mm. Available in solid, anodized aluminum or black aluminum.

**1023:** Additional charge for countersinking of cable openings and Powerdots, 111071, 111072, as well as KABELA and KABELL.



## Cable Grommet with Lamp Holder

**KABELL:** Ø75 mm including milling and lamp holder with sleeve, Ø8 - Ø16 mm. Available in solid, anodized aluminum or black aluminum. When ordering, please specify the diameter of the lamp holder.

**1023:** Additional charge for countersinking of cable grommets and Powerdots, 111071, 111072, as well as KABELA and KABELL.



## Cable Grommet

**111073:** Cable grommet Ø60 mm in black or white plastic.



## Powerdots

**111071:** Ø60 mm Powerdot midi (EL + USB-C).

**111072:** Ø60 mm Powerdot midi (EL).

Powerdots are available in black or white plastic.

**1023:** Additional charge for the recessing of cable grommets and Powerdots, 111071, 111072, as well as KABELA and KABELL.

Powerdots are supplied with plugs for the following countries: Denmark, Norway, Sweden, Finland, Germany, France, United Kingdom, Israel, Singapore, Hong Kong, Shanghai, Seoul, and the USA. The product comes with a 2-year warranty.



## Charger

**111099:** Wireless charging, Ø82 mm, mounted in a Ø79 mm hole, for newer smartphones (iPhone 8 and later) that are compatible with Qi charging.

Available in black or white. For installation in the tabletop with the same 7 standard positions as KABELA. The product comes with a 2-year warranty.

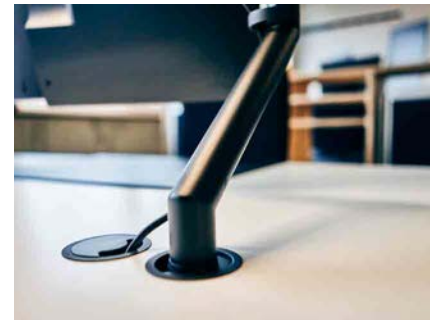

## Adaptation of Monitor Arms

We use our KABELL cable grommet (flush-mounted installation) - as an adapter point for monitor arms with a through-desk mounting solution.

For example, for the adaptation of monitor arms from Humanscale (M2.1, M8.1.) you can select KabelL as an adapter point.

Please contact us for details.

# HiLow components

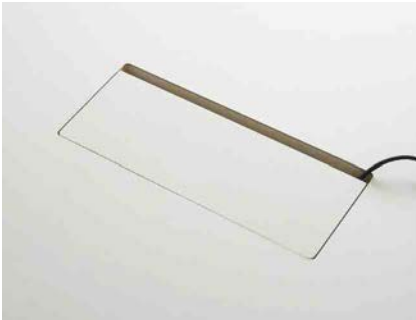

## Integrated Socket Unit\*

**111090:** W: 125 mm x L: 315 mm, integrated socket unit with a single flap available in laminate, nano laminate and linoleum (delivered in the same finish as the tabletop). Not available in micro laminate or veneer. Cannot be used with HiLow 2 corner desk (HA2PRF190) or slidetop desks.



## Integrated Socket Unit, Single

**111094:** W: 130 mm x L: 325 mm, H: 10 mm. Single socket unit in solid anodised aluminium or black anodised aluminium with horsehair finish. Not compatible with HiLow 2 corner desks (HA2PRF190) or slidetop desks.\*



## Integrated Socket Unit, Double

**111093:** W: 130 mm x L: 325 mm, H: 10 mm. Double socket unit in solid anodised aluminium or black anodised aluminium with horsehair finish. Not compatible with HiLow 2 corner desks (HA2PRF190) or slidetop desks.\*



## Mounting Tray for Socket Unit

**1110941:** W: 350 mm x H: 74 mm, mounting tray for socket unit.

Available in powder-coated Aluminium, Snow, or Black.

Used only when the socket unit is not positioned above the cable tray.



## Socket Panel

**HL111104:** Socket panel with 4 Schuko outlets for installation in a socket unit. Can be installed in HiLow Conference tables, as well as Djob Table and JW Table when used with mounting tray (1110941).

**HL111106:** Bracket for socket panel, for mounting within a socket unit.



## Waste Bin

**HS111099:** W: 190 mm x H: 240 mm x D: 320 mm. Powder-coated in Aluminium, Snow or Black. Includes waste sorting. Mounted underneath the tabletop. Removable.

\*The standard placement in HiLow work desks is either centred above the cable tray or 35 cm from the right/left edge and 10 cm from the back edge. The number of socket units in HiLow Conference tables varies depending on the table size. Tables from L: 3200 mm and upwards consist of two or more tops, allowing for one socket unit per top. **1018:** Surcharge for custom placement of components. Please include a sketch when ordering.

# HiLow components



## Control Switches, Stainless Steel

**111096:** Control switches integrated into the tabletop in stainless steel. Standard placement on the left or right side. Price per set.



## Control Switch, Black

**111097:** Control switch with memory function for two positions. Operated via the “Desk Control” app using Bluetooth. Available as a stand-alone unit or integrated into the tabletop.



## Pen Tray

**HLPEN:** W: 45.7 cm x H: 4.6 cm x D: 26.7 cm. Internal height 2.2 cm. Pen tray made of white lacquered MDF with a 12 mm front. Available in all Montana lacquer colours. The pen tray is delivered loose with the desk. Mounting the HLPEN under HiLow 2, HiLow 3, and HiLow Double desks requires a minimum depth of 75 cm. Brackets available in Black and Snow.



## Adjustable Spacers, Face-to-Face

Price per set. Available in powder-coated finishes: Aluminium, Snow, Black, Black Red, and Beige.

**SPACEFTF25:** Face-to-face spacer for tabletop distances of 2.3–4.0 cm (HiLow 2) and 1.0–2.8 cm (HiLow DFR depth 70 cm).

**SPACEFTF80:** Face-to-face spacer for tabletop distances of 7.8–14.9 cm (HiLow 2 depth 70 cm and 80 cm), 6.8–13.6 cm (HiLow DFR depth 70 cm) and 0–3.6 cm (HiLow DFR depth 80 cm and 90 cm).



## Adjustable Spacers, Side-by-Side

Price per set. Available in powder-coated finishes: Aluminium, Snow, Black, Black Red, and Beige.

**SPACESBS1:** Side-by-side spacer for desks with lengths of 140, 180 and 200 cm.

**SPACESBS2:** Side-by-side spacer for desks with lengths of 120 and 160 cm.

Both SPACESBS1 and SPACESBS2 can be used with desks with or without screens. The distance between tabletops varies depending on frame size. Please contact Montana for further specifications.



## CPU Holder

**HS111099:** Height adjustable from 35 cm to 60 cm. Depth adjustable from 8 cm to 23 cm. Available in Aluminium, Snow, and Black. Maximum load capacity is 15 kg. The CPU holder for HiLow desks in widths of 120 cm, 140 cm, 160 cm, 180 cm, and the corner desk (HA2PRF190) is delivered with a mounting bracket. HiLow desks with a length of 200 cm and the Wewerka model do not use the bracket for installation.

# HiLow components

---



## Extra Deep Cable Tray

**HA111060:** Pre-mounted cable tray.

**HS111061:** Cable tray for separate purchase.

Additional charge per desk applies when upgrading from the standard cable tray to the extra deep version. The extra deep cable tray has a depth of 10.4 cm (standard version is 7.2 cm deep). Can be installed under desks with a depth of 70 cm or more. Not compatible with slidetop desks. Only available for HiLow 2 with DL11 columns.



## Cable Sleeves

**HS111089:** 5 metres. Colour: Grey or Black. Can be shortened.

**HS111090:** 3 metres. Cable sleeve with zip fastening, allowing it to open fully along its entire length. Can be closed from both ends. Cannot be shortened.

# HiLow components — screens



## Privacy Screen for HiLow 2 and 3

12 mm lacquered MDF available in all Montana lacquer colours. Height: 55.5 cm and full width. The screen extends 42.5 cm above the tabletop and is mounted using 2 brackets. For the corner desk, 2 x SKOF190 are required.

Screen brackets are available in Snow and Black only.



## Acoustic Privacy Screen for HiLow Desks

Upholstered acoustic screen with a thickness of 4 cm, height 65 cm, and full desk width. The screen measures 42.5 cm above the tabletop and is mounted using 2–3 brackets depending on the desk size. Upholstery is available in various colours in Mica fabric by Gabriel, and Carlow and Cara fabrics by Camira.

Screen brackets are available in Snow and Black only.



## Privacy Screen for HiLow Double

12 mm lacquered MDF available in all Montana lacquer colours. Height: 80 cm and full desk width. The screen is mounted using 4 brackets on the leg frame of the base.

Screen brackets are available in Snow and Black only.



## Acoustic Privacy Screen for HiLow Double

Upholstered acoustic screen, 4 cm thick, 80 cm high, and full desk width. The screen is mounted with 4 brackets on the leg frame of the base. Upholstery is available in various colours in the fabrics Mica from Gabriel, Carlow from Camira, and Cara from Camira.

Screen brackets are available in Snow and Black only.

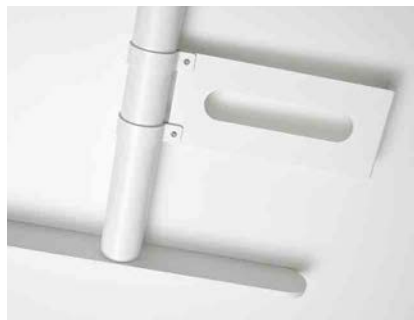

## Frame-mounted Privacy Screen, HiLow 2

12 mm lacquered MDF available in all Montana lacquer colours. The screen measures 55 cm above and 45 cm below the tabletop. Can only be mounted on HiLow 2 with DL11 columns.

Screen brackets are available in Snow and Black only.

# HiLow surfaces

HiLow 2, HiLow Double, HiLow 3, HiLow Conference

## Materials

Tabletops are available in Laminate, Silk Laminate, Linoleum, Veneer, and Nano Laminate.

As standard, tabletops are supplied with lacquered MDF edges that match the surface, or with painted edges in colours corresponding to the standard surfaces – except for veneer finishes. The veneer grain direction always runs lengthwise. Slight variations in the veneer pattern may occur.

### Linoleum

HiLow 2, HiLow 3, HiLow Double, HiLow Conference



**Linoleum**  
Mushroom / Forbo 4176



**Linoleum**  
Ash / Forbo 4132



**Linoleum**  
Charcoal / Forbo 4166



**Linoleum**  
Nero / Forbo 4023



**Linoleum**  
Mauve / Forbo 4172



**Linoleum**  
Burgundy / Forbo 4154



**Linoleum**  
Pistachio / Forbo 4183



**Linoleum**  
Olive / Forbo 4184



**Linoleum**  
Walnut / Forbo 4003

### Laminate

HiLow 2, HiLow 3, HiLow Double, HiLow Conference

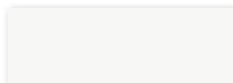

**Laminate** 38L Snow Silk

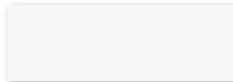

**Laminate** 38L Snow



**Laminate** 09L Nordic



**Laminate** 02L Fjord



**Laminate** 04L Anthracite



**Laminate** 157L Cumin



**Laminate** F3050L Cygnet



**Laminate**  
F8240L Liquid glass

### Micro Laminate

HiLow 2, HiLow 3, HiLow Double

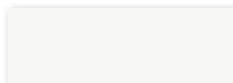

**Micro Laminate:** 38ML Snow



**Micro Laminate:** 02ML Fjord

### Nano Laminate

HiLow 2, HiLow 3, HiLow Double, HiLow Conference



**Nano Laminate**  
0718N Clay



**Nano Laminate**  
0754N Blue Fes



**Nano Laminate**  
0720N Black



**Nano Laminate**  
0789N Rosso Namib

### Veneer

HiLow 2, HiLow 3, HiLow Double, HiLow Conference



**Veneer** White Oak 131F



**Veneer** Nature Oak 62F



**Veneer** Black Oak 133F

# HiLow frame & privacy screens

HiLow 2, HiLow Double, HiLow 3, HiLow Conference

## Frame

The DL11 is a compact, round, three-part lifting column with an integrated motor. Its profile is protected against rotation and torsion. The DL11 has a compact motor housing, which is almost concealed within the frame construction, and the lifting column is exceptionally sturdy. External dimensions: Ø70 mm. The DL11 system is powered by a control box, ensuring optimal parallel movement and a pleasantly low noise level.

**The DFR frame** features a round, three-part lifting column with a motor in one leg that drives the parallel motion of the frame. **The HiLow 3 frame** is identical to the DFR, but with a rectangular profile.

## Screen for HiLow 2 and 3 + Frame-mounted screen for HiLow 2 and HiLow Double

12 mm MDF lacquered in all Montana colours.

### Frame Colour

#### Powder-Coated

For HiLow 2 and HiLow Conference, DL11 columns are available in Beige, Black Red, Shadow, and Pine at an additional cost.

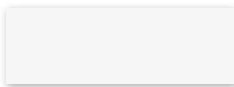

Powder Coat Snow 38



Powder Coat Black 05

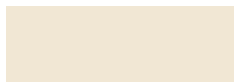

Powder Coat Beige15



Powder Coat Black Red 07



Powder Coat Shadow 147



Powder Coat Pine 136

### Frame Colour

#### Powder-Coated

HiLow 3, HiLow Double

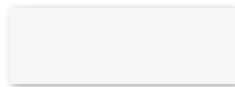

Powder Coat Snow 38



Powder Coat Black 05

### Frame Colour

#### Powder-Coated Aluminium

HiLow 2, HiLow 3, HiLow Double, HiLow Conference



Powder Coat Aluminium 43P

### Frame

#### Chrome

Available for HiLow 2 and HiLow Conference with DL11 and fixed columns, subject to additional charge.



Chrome Chrome 44C

## Acoustic Privacy Screens for HiLow 2, HiLow 3 and HiLow Double

Available in Cara by Camira, Carlow by Camira, and Mica by Gabriel.



Camira Cara 375 Glass



Camira Cara 377 Lomond



Camira Cara 378 Lewick



Camira Cara 379 Maree



Camira Carlow 220 Convoy



Camira Carlow 223 Tallow



Camira Carlow 227 Emly



Camira Carlow 228 Quin

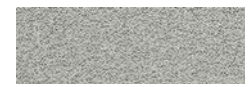

Mica 100



Mica 101



Mica 102



Mica 103



Mica 104



Mica 105

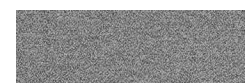

Mica 106



Mica 107



Mica 108

Please note that printed colours may differ from the original colour.



# HiLow Speaker

1 model /

Design: Peter Lassen / Joakim Lassen / Henrik Leander



## Lectern on Castors

HiLow Speaker is a height-adjustable lectern with electric lift function, allowing it to be individually adapted to the speaker. It features a surface suitable for placing a laptop, notes, or a glass. A discreet cable cut-out allows connection to power and network. The lectern opens to accommodate electronic equipment and cable management, and is fitted with castors for easy mobility.

### Technical Information

The lectern is equipped with electric height adjustment. The horizontal surface is finished in black linoleum. An optional front panel in 12 mm lacquered MDF can be mounted beneath the lectern, and integrated lighting is also available. The front panel moves together with the lectern during height adjustment.

The frame uses DL11 columns and is supplied as standard in 43P Aluminium, 38 Snow and 05 Black; also available at a surcharge in Beige, Black Red, Shadow, Pine, and Chrome.

# HiLow Speaker overview

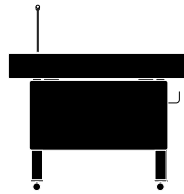
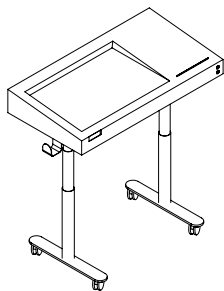

## HA2TA115

The lectern features electric height adjustment. The horizontal surface is finished in black linoleum. A front panel in 12 mm MDF or integrated lighting can be added beneath the lectern. The front panel moves in sync with the lectern during height adjustment.

## Components

288

## Surfaces

289

### Height-adjustable Lectern

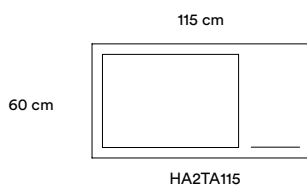
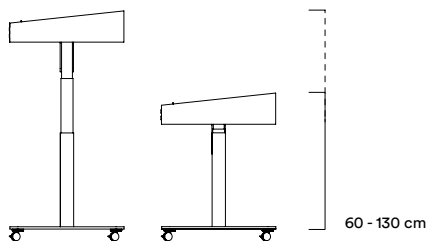

# HiLow Speaker components

---



## Manuscript light

Black lamp with switch, designed for use with the HiLow Speaker.

**Model** TA213010  
**Material** Black metal

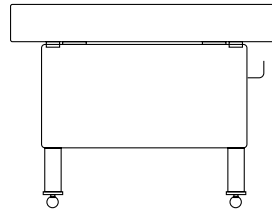

## Front panel

The front panel is mounted beneath the lectern.

**Model** TAFHA2  
**Material** 12 mm MDF  
Available in all Montana lacquer colours.  
The front panel is attached beneath the lectern and moves with it during height adjustment.  
**Dimensions:** 88.6 cm x 45.0 cm.

# HiLow Speaker surfaces — lectern

## Materials

**Lectern:** The HiLow Speaker lectern is made from MDF and is available in all Montana lacquer colours. The horizontal surface is finished with black linoleum.

## Lacquered MDF

HiLow Speaker is available in all Montana lacquer colours.



# HiLow Speaker frame

---

## Materials

The frame is supplied as standard in powder-coated finishes: 38 Snow, 05 Black, and 43P Aluminium.

### Powder-Coated

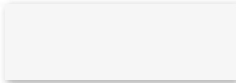

Powder Coat 38 Snow



Powder Coat 05 Black



Powder Coat  
43P Aluminium

### Powder-Coated

Available at an  
additional cost.



Powder Coat 07 Black Red



Powder Coat 15 Beige



Powder Coat 147 Shadow



Powder Coat 136 Pine

### Chrome

Available at an  
additional cost.



Chrome 44C Chrome



# SHL Table

2 models / Design: shldesign



## Exclusive Office Desk

The SHL Table was designed by Schmidt Hammer Lassen Architects in 2007. This height-adjustable desk, with elegant gable ends and a clean design, was developed from a manual version originally created for the architects' own studio. The SHL Table can be used as a workstation, meeting table, or reception desk.

### Technical Information

The gable table is available in two sizes with an electric height-adjustment function, allowing for both seated and standing use. The depth of the tabletop provides ample space for a keyboard, monitor, arm support, and optimal viewing distance.

Tabletops are available in Laminate, Silk Laminate, Nano Laminate, Linoleum, and Veneer.

Laminate tops feature lacquered MDF edges matching the surface. Linoleum tops come with linoleum edges, and veneer tops are finished with solid wood edge bands.

## Full-Length Gable Ends

The desks feature electric height adjustment with fully enclosing gable ends that remain continuous and fully cover the frame at both the highest and lowest positions.

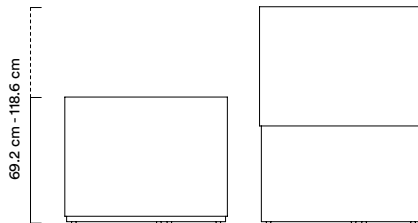

## Table Sizes

The gable desk is height-adjustable from 69.2 cm to 118.6 cm.

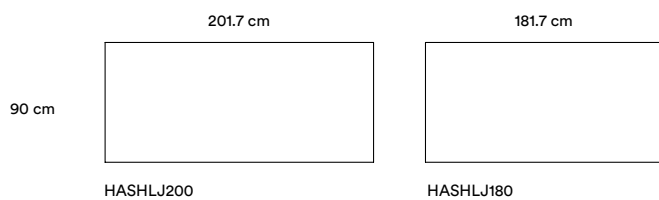

## Table Routing and Steel Control Switches in Tables

The diagrams indicate the possible positions for cable grommets and steel control switches. Cable grommets, lamp holders, and power dots have seven possible positions. Please specify the desired position when ordering – for example, “1L” refers to the outermost position on the left. The positions for steel control switches are shown as two dots in the diagrams, indicating left and right placement.

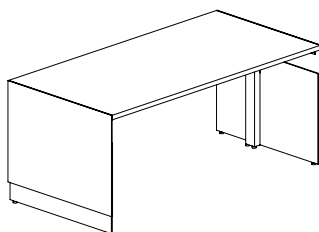
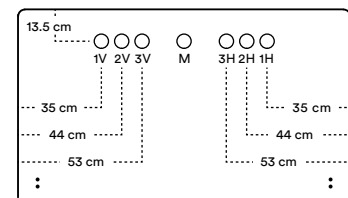

### HASHLJ200

W 201.7 x H 90 cm

The panel-leg table can be height-adjusted from 69.2 cm to 118.6 cm.

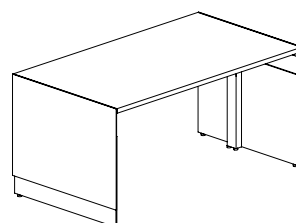

### HASHLJ180

W 181.7 x H 90 cm

The panel-leg table can be height-adjusted from 69.2 cm to 118.6 cm.

# SHL Table surfaces

## Gables

Gables and other frame components are available in colours 38 Snow and 05 Black. The SHL Table is delivered with a cable tray included.

## Table Tops

Tabletops in laminate come with lacquered MDF edges matching the surface. Linoleum tops have linoleum edges, while veneer tabletops feature solid wood edge strips.

### Linoleum



**Linoleum**  
Mushroom / Forbo 4176



**Linoleum**  
Ash / Forbo 4132



**Linoleum**  
Charcoal / Forbo 4166



**Linoleum**  
Nero / Forbo 4023



**Linoleum**  
Mauve / Forbo 4172



**Linoleum**  
Burgundy / Forbo 4154



**Linoleum**  
Pistachio / Forbo 4183

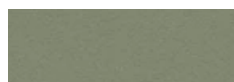

**Linoleum**  
Olive / Forbo 4184



**Linoleum**  
Walnut / Forbo 4003

### Laminate

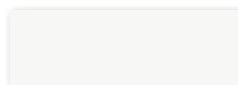

**Laminate** 38L Snow Silk

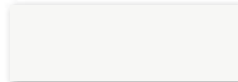

**Laminate** 38L Snow



**Laminate** 09L Nordic



**Laminate** 02L Fjord



**Laminate** 04L Anthracite



**Laminate** 157L Cumin



**Laminate** F3050L Cygnet



**Laminate**  
F8240L Liquid glass

### Nano Laminate



**Nano Laminate**  
0718N Clay



**Nano Laminate**  
0754N Blue Fes



**Nano Laminate**  
0720N Black



**Nano Laminate**  
0789N Rosso Namib

### Veneer



**Veneer** White Oak 131F



**Veneer** Nature Oak 62F



**Veneer** Black Oak 133F

### Gable and Frame

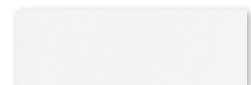

**Powder Coat** 38 Snow



**Powder Coat** 05 Black



# Tables

## Load Capacity Overview



# Load capacity overview for tables

---

Below is a table showing the load capacity limits for all tables.

	Load Capacity	Description
<b>Monterey</b>	100 kg*	*Tables
<b>JW Table</b>	80 kg	
<b>Multi Cafe</b>	20 kg	
<b>Multi Speaker</b>	20 kg	
<b>Panton Table</b>	20 kg	Evenly distributed.
<b>Kevi Table</b>	80 kg	Evenly distributed.
<b>Moser Table</b>	80 kg	Evenly distributed.
<b>Foldit Table</b>	100 kg	Evenly distributed.
<b>Djob Table</b>	120 kg	Evenly distributed.
<b>HiLow 2</b>	120 kg	Evenly distributed.
<b>HiLow Double</b>	120 kg	Evenly distributed.
<b>HiLow 3</b>	120 kg	Evenly distributed.
<b>HiLow Conference</b>	120 kg	Evenly distributed.
<b>HiLow Speaker</b>	40 kg	
<b>SHL Table</b>	120 kg	Evenly distributed.

\*Applies to tables only.





# PANTON







# INDEX — Panton

---

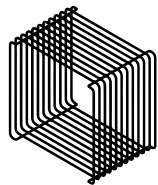

---

**Panton Wire**

102



---

**Panton One**

194

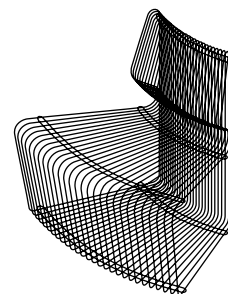

---

**Pantonova**

212



---

**Panton Table**

242



# ACCESSORIES





# Accessories

12 mm MDF / Design: Peter J. Lassen

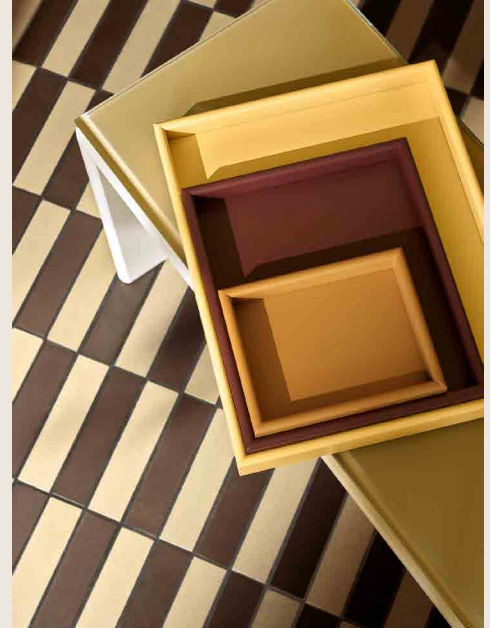

## Functional Mirrors and Small Storage

Montana Accessories includes a range of colourful mirrors, practical trays, spacious storage boxes, and stylish notice boards.



# Accessories overview

---

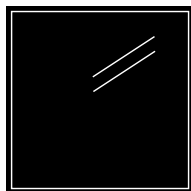

Mirrors

304



Storage Boxes

306

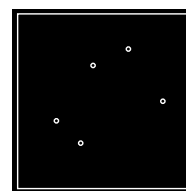

Magnetic Noticeboard

308



Coat Racks

309

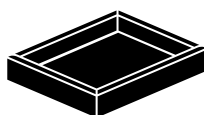

Trays and Small Storage

310



Cushions

50

Find more information about cushions under System Seating page 50 >



Surfaces

313

# Colour Frame Mirror

EU ECOLABEL CERTIFIED

## Mirrors in Many Sizes

Colour Frame Mirrors are available in a wide range of shapes and sizes, making it easy to find the perfect mirror for the hallway, bathroom, wardrobe, or vanity area. The series includes both rectangular and round designs that can be used on their own or combined with the Montana shelving system.



---

### Technical Information

The mirrors are available in all Montana lacquer colours and are made from 4 mm silvered glass mounted on 12 mm MDF with a 13 mm wide frame. They feature four mounting holes and can be installed either horizontally or vertically. All mirrors are suitable for use in damp environments, but should not be exposed to direct water contact.



# Colour Frame Mirror

The mirrors are produced from 4 mm silvered glass on 12 mm MDF board with a 12 mm mirror frame.

D: 1,6 cm\*

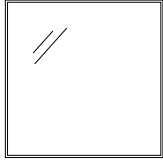

(\*18 x \*18)

**SP1818** W 105 cm H 105 cm

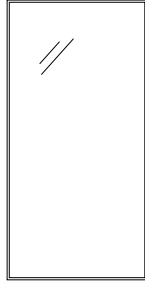

(\*32 x \*16)

**SG3216** W 93.2 cm H 186.4 cm

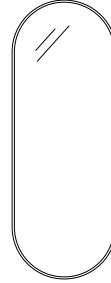

(\*32 x \*12)

**SP1232R** W 69.6 cm H 186.4 cm



(\*32 x \*8)

**SG3208** W 46.8 cm H 186.4 cm

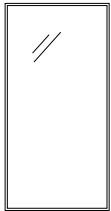

(\*24 x \*12)

**SP1224** W 69.6 cm H 139.2 cm

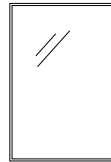

(\*18 x \*12)

**SP1812** W 69.6 cm H 105 cm



**FIGURE** (\*8 x \*24)

**SP824R** W 46.8 cm H 138 cm

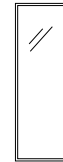

**LIKE** (\*18 x \*6)

**SP1806** W 35.4 cm H 105 cm



(\*12 x \*12)

**AROUND**  
**SP1212R** Ø 69.6 cm



(\*12 x \*12)

**SP1212** W 69.6 cm H 69.6 cm



**LOOK** (\*8 x \*12)

**SP1812R** W 46.8 cm H 69.6 cm



(\*8 x \*8)

**SP808** W 46.8 cm H 46.8 cm



(\*12 x \*8)

**SP1208** W 46.8 cm H 69.6 cm



**SHELFIE** (\*12 x \*8)

**SPB1208K\*** D 10 cm  
W 46.8 cm H 69.6 cm

\* SPB1208 is D: 10 cm

# Colour Boxes

EU ECOLABEL CERTIFIED

## Storage Boxes on Castors or Legs

Colour Boxes is a series of versatile storage boxes with one or two compartments, available with either castors or legs. The boxes can be selected in all Montana lacquer colours and offer a flexible storage solution for the home. They are ideal for storing toys, vinyl records, clothing, or other items that require a practical and stylish storage option.



---

### Technical Information

Colour Boxes are storage modules available in six different sizes, with or without internal dividers. The modules are made from 12 mm MDF and are available in all Montana lacquer colours. Each module has a reinforced 16 mm base and can be fitted with SRCO castors in a matching colour or with legs. All modules come with a loose transparent protective plastic sheet for the base. Dividers are adjustable. Maximum load: 15 kg.

**Note:** If the modules are used for plants, care must be taken to avoid water spillage into the bottom of the unit. Plants must be placed in waterproof saucers.



# Colour Boxes

Colour Boxes with legs: Height 42.6 cm / Colour Boxes with castors: Height 37.8 cm

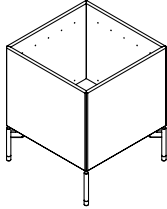

(\*6 x \*6)

**S6161 Legs**

W 35.4 cm x D 35.4 cm

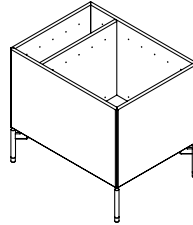

(\*6 x \*8)

**S4162 Legs**

W 46.8 cm x D 35.4 cm

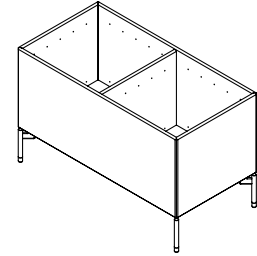

(\*6 x \*12)

**S1162 Legs**

W 69.6 cm x D 35.4 cm

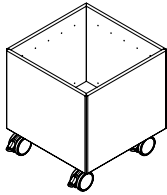

(\*6 x \*6)

**S6161 Castors**

W 35.4 cm x D 35.4 cm

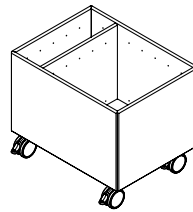

(\*6 x \*8)

**S4162 Castors**

W 46.8 cm x D 35.4 cm

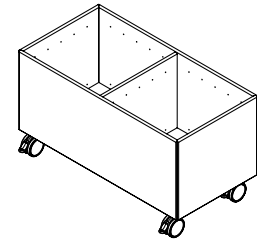

(\*6 x \*12)

**S1162 Castors**

W 69.6 cm x D 35.4 cm

# Noticeboard

EU ECOLABEL CERTIFIED

## Magnetic Noticeboard

The Montana Noticeboard is a magnetic pinboard ideal for the home office, hallway, or any space where messages and reminders are needed. It is made from a thin steel sheet mounted on a 12 mm MDF backboard and is available in all Montana lacquer colours.

Multiple boards can be combined to create a larger display surface or a decorative play of colours. Supplied with five magnets in the same colour as the board and wall mounting screws.



### Technical Information

Noticeboard 69.6 × 69.6 cm (\*12 x \*12)

#### BM1212:

12 mm MDF board available in all Montana lacquer colours with a 1 mm steel sheet.  
Mounted on the wall using screws.  
Supplied with 5 lacquered magnets.

Please note: The Noticeboard is not suitable for use with whiteboard markers.

#### MINMAG:

Set of 5 lacquered magnets for the Montana Noticeboard. Diameter: 1.2 cm , height: 1.6 cm. Available in all Montana lacquer colours.

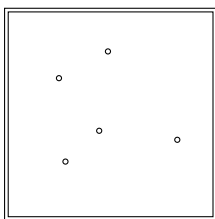

BM1212

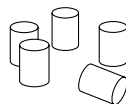

MINMAG

# Coat Racks

EU ECOLABEL CERTIFIED

## Racks for Multiple Purposes

Coat Racks help keep jackets, scarves, and keys organised in both home and office settings. Available with four or six hooks, the coat racks are suitable for spaces of all sizes. They come in 41 curated lacquer colours and can be combined with a shoe bench to create a practical and stylish hallway solution.



### Technical Information

#### Coat Racks

12 mm MDF panels with hooks and wall mounting.

**K1212:** H: 10 x W: 69.6 cm (\*12). K1212 comes fitted with 6 hooks in powder-coated metal.

**K812:** H: 10 x W: 46.8 cm (\*8). K812 comes fitted with 4 hooks in powder-coated metal.

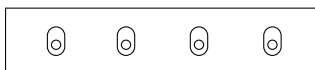

K812



K1212

# Trays & Organisers

EU ECOLABEL CERTIFIED

## Small Storage

Montana trays are finished with a reinforced PUR lacquer, making them suitable for serving and use in kitchens and wet areas. Tray sets are available in predefined colour combinations. The trays can be purchased individually in three sizes or as sets of two or three. COLLECT and CLASSIFY are small storage modules ideal for use on a desk – available in all Montana lacquer colours.



# Trays & Organisers

---

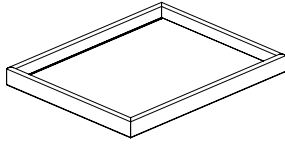

TRAY Large

---

**Arrange Tray**     D 32.9 x W 41.7 x H 4.5 cm

---

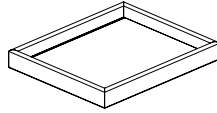

TRAY Medium

---

**Arrange Tray**     D 24.9 x W 30.2 x H 4.5 cm

---

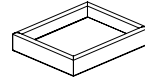

TRAY Small

---

**Arrange Tray**     D 14.9 x W 18.9 x H 4.5 cm

---

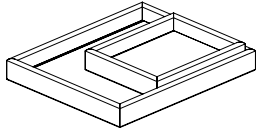

TRAYS Medium + Small

---

**Arrange Tray / Set of 2**

---

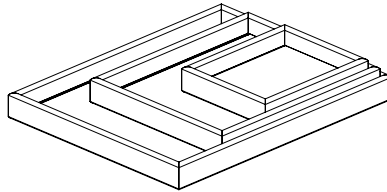

TRAYS Large + Medium + Small

---

**Arrange Tray / Set of 3**

---

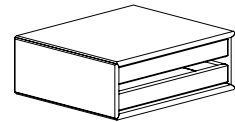

ORGANISERS (\*6 x \*2)

---

**CLASSIFY (8161)**     H 12.6 x W 35.4 x D 30 cm

---

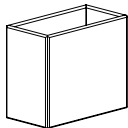

ORGANISERS (\*2 x \*4)

---

**COLLECT (8171)**     H 20 x W 24 x D 12.6 cm

---



# Accessories surfaces

## Materials

**Colour Frame Mirror, Colour Boxes, Montana Noticeboard, Coat Racks, Organisers:** Lacquered MDF.

**Trays:** The trays are finished in a reinforced PUR lacquer, making them suitable for serving and use in kitchens and bathrooms.

Models **41T, 61T, 81T** are available in the following colours: 142 Amber, 155 Masala, 166 Acacia, 167 Ruby.

Tray sets\* are available in predefined colour combinations, also in PUR lacquer:

– **TRSET1** is available in 2 combinations only: Amber (41T) & Acacia (61T) or Ruby (41T) & Masala (61T).

– **TRSET2** is available in 2 combinations only: Amber (41T), Masala (61T) & Acacia (81T) or Masala (41T), Amber (61T) & Ruby (81T).

**Lacquered MDF** is used for all products listed:

Colour Frame Mirror, Colour Boxes, Montana Noticeboard, Coat Racks, Trays & Organisers.

**NOTE:** TRSET1\*, TRSET2\* are only available in selected colours.

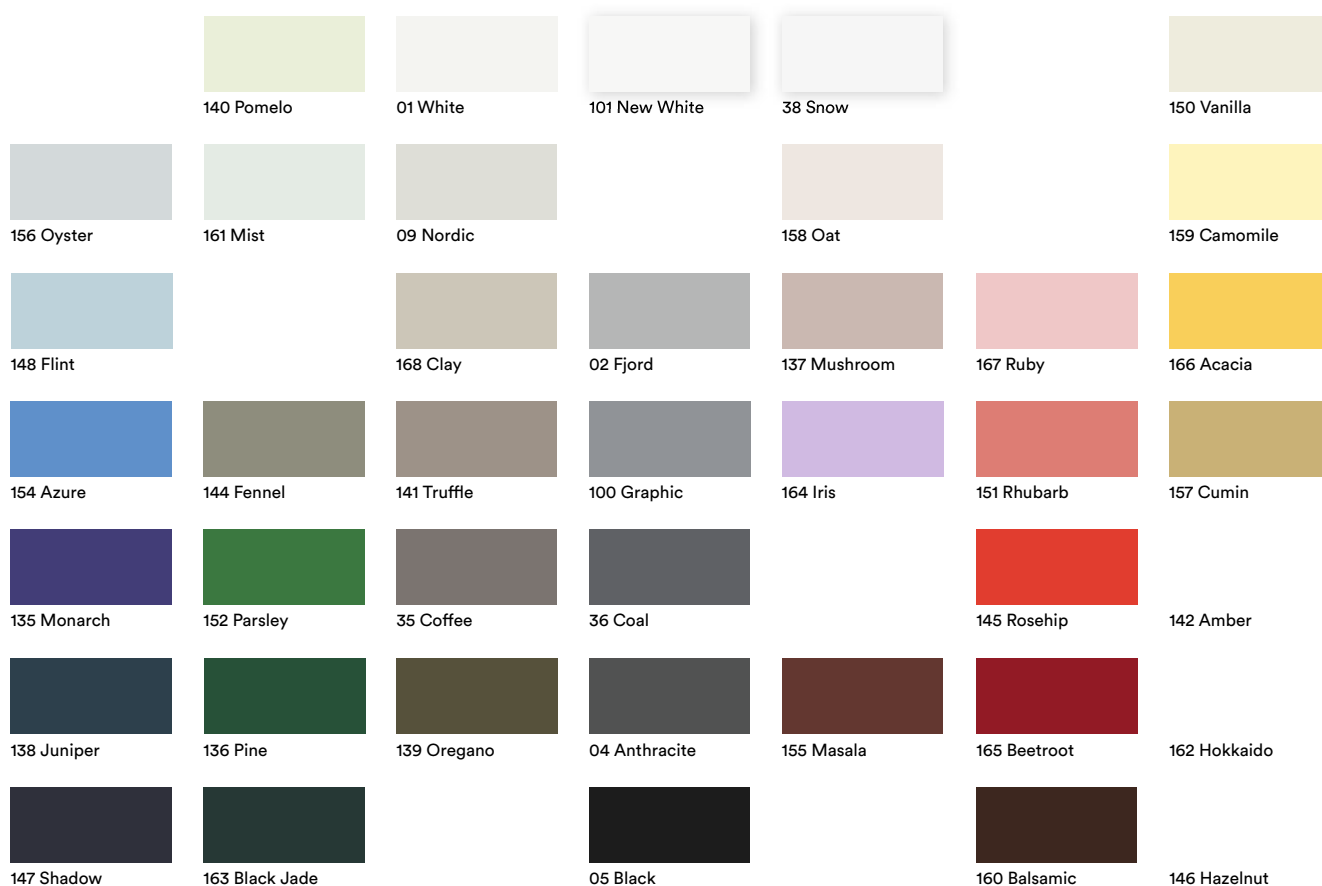

## Legs and Colourbox

Available in a selection of Montana's lacquer colours, matt chrome-plated zinc, and brass.

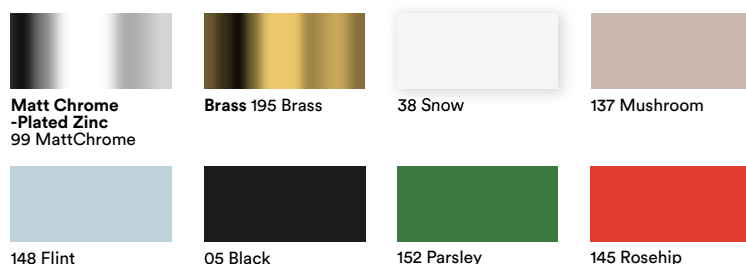

## Castors

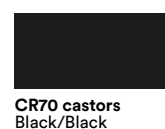



# BATHROOM





# Bathroom

12 mm MDF / Design: Peter J. Lassen



## Bathroom Furniture

Montana Bathroom is a complete and flexible bathroom series that allows you to combine washbasin modules, storage, and mirrors to suit your needs. The series is crafted from 12 mm water-resistant MDF and is available in a range of sizes that balance aesthetics with functionality. All modules, mirrors, handles, and doors are available in Montana's full palette of water-based lacquer colours, offering the opportunity to create a personal and cohesive bathroom design. Montana Bathroom is designed exclusively for wall mounting and provides an elegant, timeless solution for contemporary interiors.



# Bathroom overview

---

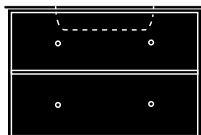

**Basin Modules**

318

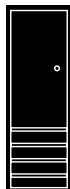

**Storage Modules**

320

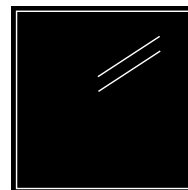

**Mirrors**

304

See under accessories on page 304 >



**Surfaces**

322



**Technical Information**

324

# Bathroom

EU ECOLABEL CERTIFIED

## Basin Modules

Montana Bathroom offers countertops with integrated basins in the silky-smooth composite material Rector®. The countertop is available in three colours: White, Beige Grains, and Black Grains, with the latter two featuring dark and light grain details respectively.



### Technical Information

The modules in the Montana Bathroom series are made from water-resistant 12 mm MDF. To minimise the impact of moisture in bathroom environments, no pre-drilled pilot holes are included in the modules—this also means that additional shelves cannot be retrofitted.

The drawer beneath the basin is cut out to accommodate plumbing fixtures such as valves and fittings. In modules with two drawers, only the upper drawer will have this cut-out by default—if required in both drawers, this must be specified when ordering. Doors and drawers can be supplied with either a push function or G7 handle.

Basin modules in widths of \*12 and \*18 are fitted with a robust metal reinforcement rail at the front edge. All basin modules in these widths also feature a lacquered interior support rail at the bottom to reinforce the module base. Mounting: Basin modules are wall-mounted using a special steel bracket (OP4V).

**Load capacity:** 50 kg per module.

The basin is seamlessly integrated into the countertop and made of Rector®, a 12 mm white composite material with a silky matte finish. It is supplied with a Ø35 mm tap hole, which can be omitted if specified. The basin has an overhang of 1.2 cm at the front and 0.8 cm on the sides.

**Important:** Rector does not tolerate temperatures above 65°C. The flow temperature must not exceed this limit, as rapid changes between hot and cold may cause the basin to crack.

**Warranty:** Rector products are covered by a 5-year warranty.

**Installation:** The basin and module must be sealed together during installation, using a transparent sanitary-grade silicone sealant recommended for wet rooms.

# Sink Modules overview

The basin is integrated into the countertop.  
The doors are available with a push-to-open function or with G1 and G7 handles.

Measurements incl. sink

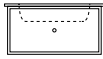

Module below table top: (\*8 x \*4)

**BR0801** W 48.4 cm D 39.2 cm H 25.2 cm

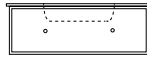

Module below table top: (\*12 x 4)

**BR1201** W 71.2 cm D 48 cm H 25.2 cm

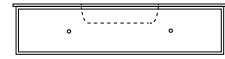

Module below table top: (\* x \*4)

**BR1801** W 105.4 cm D 48 cm H 25.2 cm

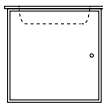

Module below table top: (\*8 x \*8)

**BR0802** W 48.4 cm D 39.2 cm H 48 cm

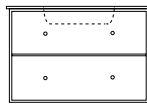

Module below table top: (\*12 x \*8)

**BR1202** W 71.2 cm D 48 cm H 48 cm

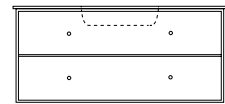

Module below table top: (\*18 x \*8)

**BR1802** W 105.4 cm D 48 cm H 48 cm

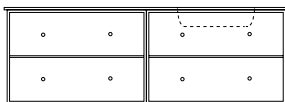

**BR2402** W 140.8 cm D 48 cm H 48 cm

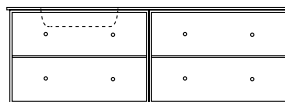

**BR2404** W 140.8 cm D 48 cm H 48 cm

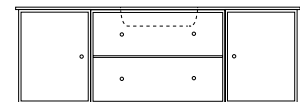

**BR2405** W 142 cm D 48 cm H 48 cm

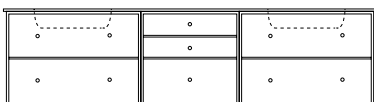

**BR3201** W 187.6 cm D 48 cm H 48 cm

# Bathroom

EU ECOLABEL CERTIFIED

## Storage Modules

Montana Bathroom offers a wide selection of wall-mounted cabinets and storage modules with shelves, trays, and doors. The doors are available with a push-to-open function or a choice between two handle types, providing flexible solutions for any bathroom layout.



---

### Technical Information

The modules are made from 12 mm water-resistant MDF and are constructed without pre-drilled shelf holes. Storage modules include shelves, trays, and doors. Doors are available with either a push-to-open mechanism or the G7 handle.

# Storage Modules overview

Storage modules with shelves, trays, and doors.  
The doors are available with push-to-open function, or with G1 or G7 handles.



(\*4 x \*8)

**OV1215**

W 24 cm D 20 cm H 46.8 cm



(\*4 x \*8)

**OV1216**

W 24 cm D 20 cm H 46.8 cm

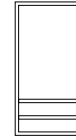

(\*4 x \*8)

**OV1217**

W 24 cm D 20 cm H 46.8 cm

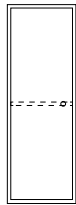

(\*4 x \*12)

**PV1215**

W 24 cm D 20 cm H 69.6 cm



(\*4 x \*12)

**PV1216**

W 24 cm D 20 cm H 69.6 cm



(\*4 x \*12)

**PV1217**

W 24 cm D 20 cm H 69.6 cm

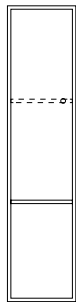

(\*4 x \*18)

**KV1220**

W 24 cm D 20 cm H 103.8 cm

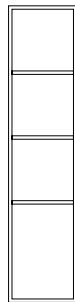

(\*4 x \*18)

**KV1221**

W 24 cm D 20 cm H 103.8 cm

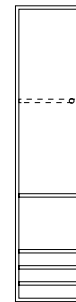

(\*4 x \*18)

**KV1222**

W 24 cm D 20 cm H 103.8 cm

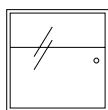

(\*6 x \*6)

**PARFUME**

W 35.4 cm D 20 cm H 35.4 cm

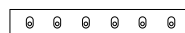

(B \*12)

**K1212**

W 69.6 cm D 5.4 cm H 10 cm



(B \*8)

**K812**

W 46.8 cm D 5.4 cm H 10 cm

# Bathroom surfaces

## Materials

Montana Bathroom is crafted from 12 mm water-resistant MDF. All modules, mirrors, handles, and doors are available in all 41 of Montana's water-based lacquer colours.

## Countertop with Basin

Montana basin modules are available in various sizes with seamlessly integrated basins. These are made from 12 mm Rector® – a composite material with a silky matte surface – available in three colours. The countertop is supplied as standard with a 35 mm centrally positioned tap hole above the basin. The drawer below the basin includes a cut-out for the waste fitting. Any non-standard configurations must be specified when placing the order. Montana Bathroom elements are supplied exclusively for wall mounting.

## Lacquered MDF

Bathroom is available in all Montana lacquer colours.



## Basin/Table Top



Please note that printed colours may differ from the original colour.





# Bathroom Technical Information



# Technical Information

---

## Montana Bathroom

### Handles and Functionality

Montana Bathroom modules are delivered as standard with the cylindrical G7 handle featuring a frosted acrylic insert. Alternatively, they can be fitted with a push function or the G6 cylindrical handle.

### Materials and Construction

Montana Bathroom modules are made from 12 mm water-resistant MDF, developed to withstand humid environments. To reduce moisture impact, the cabinets have no pre-drilled shelf holes on the inside, distinguishing them from the Montana System.

### Basin Modules

Montana basin modules are produced from 12 mm Rector® – a robust, solid composite material with a silky matte finish, developed by the Danish worktop manufacturer Kuma. Its non-porous surface prevents bacterial growth, making it hygienic and easy to clean. For care and maintenance, refer to Kuma's maintenance guide.

### Waste Outlet and Tap Holes

- Countertops with integrated basins are supplied with a standard 35 mm tap hole, centrally positioned behind the basin.
- The waste outlet measures 46 mm and is compatible with international pipe systems.
- Countertops are supplied with tap holes as standard but can be ordered without if specified.
- The drawer beneath the basin includes a cut-out for plumbing components such as valves.  
In two-drawer modules, only the top drawer features this cut-out unless otherwise specified at the time of ordering.

### Customisation of Basin Modules

If the waste outlet is floor-mounted, a cut-out in the bottom drawer can be pre-prepared:

- In height 24 cm (\*4) modules, holes in the module base are pre-drilled.
- In height 46,8 cm (\*8) modules, the cut-out must be made on-site to ensure a precise fit.

Basin modules in widths 69,6 cm (\*12) and 103,8 cm (\*18) feature a metal support rail along the front edge for added stability. Additionally, a lacquered SS10 panel board matching the module colour is placed at the base for enhanced durability.

### Installation and Mounting

Montana basin modules are securely fixed using steel wall brackets (OPV4).

- In height 24 cm (\*4) and 46,8 cm (\*8) modules, the top drawers are shorter to accommodate the OPV4 brackets.
- Maximum load per unit: 50 kg.
- Recommended mounting height: 85–86 cm from the floor (adjustable as needed).

## Frequently Asked Questions (FAQ)

### Can Montana Bathroom modules withstand humid environments?

Yes, Montana Bathroom modules are made of water-resistant MDF, specially designed for wet rooms. However, visible water should be wiped off to maintain the module's condition.

### What material are the basin countertops made from, and how should they be cleaned?

The countertops are made from Rector®, a composite material with a smooth, hygienic, non-porous surface. Most cleaning agents are suitable, though a KUMA cleaning kit is recommended for optimal care.

### Is the tap hole a standard size?

Yes, the 35 mm tap hole fits all standard tap fittings.

### How do I allow for pipes if the waste outlet is in the floor?

If floor-mounted, a cut-out can be ordered for the lower drawer. In height \*4 modules, holes are pre-drilled as standard. In height \*8 modules, the cut-out should be made on-site for a precise fit.

### Can I order the basin countertop without a tap hole?

Yes. While tap holes are standard, a no-hole version can be ordered if specified at the time of purchase.





# Montana Colour Technical Information



# Replenishment Guarantee – Colours

---

## **Replenishment Guarantee – Colours (2011–2019)**

Montana products are a reliable, long-term investment, supported by a biannual replenishment service for colours from 2011–2019.

Available in Week 14 (order by 1st February) and Week 40 (order by 1st August), with a 30% surcharge.

**Please note:** minor variations in lacquer shades may occur due to changes in technology and raw materials.



# Replenishment Guarantee – Colours

## Colours (2011–2019)

Black Zone	White Zone	Urban Nature	Candy	Coco	Global	Manga
 02 Fjord	 101 New White	 104 Milk	 109 Lemon Drop	 215 Boulevard	 121 Madras	 125 Tokyo Yellow
 100 Graphic	 101 New White Gloss	 105 Lounge	 110 Peach	 216 Cabernet	 48 Burma	 126 Yoko Orange
 04 Anthracite	 38 Snow	 106 Latte	 111 Candy Floss	 217 Moulin Rouge	 10 China Red	 127 Zen Red
 36 Coal	 01 White	 35 Coffee	 112 Violetta	 218 Montparnasse	 122 Rio	 128 Ginza Pink
 65 Black Snow	 103 Frost	 107 Air	 113 Peppermint	 219 Royale	 123 Marocco	 129 Kyoto Blue
 05 Black	 09 Nordic	 108 Green Tea	 114 Pistachio	 220 Botanique	 124 Amazonas	 130 Umami Green



# Montana colours translated to NCS and RAL

	 140 Pomelo S 1010 - G60Y -	 01 White S 1002 - Y -	 101 New White S 0300 - N RAL 9003	 38 Snow S 0500 - N RAL 9016		 150 Vanilla S 1005 - Y20R RAL 1013
 156 Oyster S 2005 - B20G -	 161 Mist S 1510 - G RAL 9018	 09 Nordic S 2002 - G50Y RAL 7035		 158 Oat S 1005 - Y60R -	 131 White Oak -	 159 Camomile S 0530 - G90Y RAL -
 148 Flint S 1515 - B20G -		 168 Clay S 2005 - Y30R -	 02 Fjord S 3502 - B RAL 7040	 137 Mushroom S 3010 - Y70R -	 167 Ruby S 1020 - Y90R -	 166 Acacia S 0560 - Y10R -
 154 Azure S 2060 - R90B -	 144 Fennel S 5010 - G90Y RAL 7003	 141 Truffle S 4005 - Y50R -	 100 Graphic S 5005 - R80B RAL 7046	 164 Iris S 1030 - R50B -	 151 Rhubarb S 1060 - Y90R -	 157 Cumin S 3030 - Y10R RAL 1002
 135 Monarch S 4550 - B70B RAL 5002	 152 Parsley S 4050 - G10Y RAL 6001	 35 Coffee S 6005 - Y50R -	 36 Coal S 7500 - N -		 145 Rosehip S 1080 - Y90R RAL 3028	 142 Amber S 4050 - Y30R RAL 8001
 138 Juniper S 7020 - R90B -	 136 Pine S 7020 - B90G RAL 6005	 139 Oregano S 7020 - G90Y RAL 7013	 04 Anthracite S7502 - B RAL 7024	 155 Masala S 6030 - Y80R RAL 8015	 165 Beetroot S 2570 - R RAL 3003	 162 Hokkaido S 2570 - Y70R -
 147 Shadow S 8010 - R70B RAL 5011	 163 Black Jade S 8005 - B80G RAL 6012		 05 Black S 9000 - N RAL 9011	 133 Black Oak -	 160 Balsamic S 8505 - Y80R RAL 8019	 146 Hazelnut S 5040 - Y70R RAL 8004



# Montana Lacquer Colours Surface overview

---

## MATT HIGH STRUCTURE

Look: Matt / Feel: High Structure



135  
Monarch



136  
Pine



137  
Mushroom

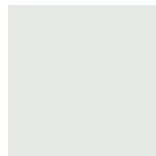

161  
Mist

## MATT MICRO STRUCTURE

Look: Matt / Feel: Micro Structure

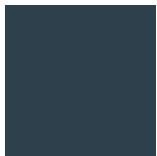

138  
Juniper



139  
Oregon

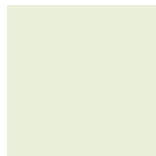

140  
Pomelo

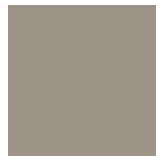

141  
Truffle



142  
Amber



167  
Ruby

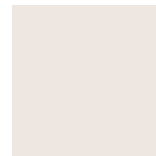

168  
Clay

## MATT STRUCTURE

Look: Matt / Feel: Structure

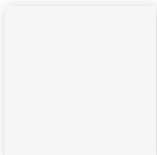

38  
Snow

## MATT SHIMMER STRUCTURE

Look: Matt Shimmer / Feel: Structure



35  
Coffee



36  
Coal



163  
Black Jade

## VENEER

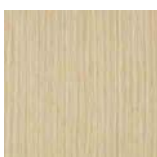

131  
White Oak



133  
Black Oak



# Montana Lacquer Colours Surface overview

---

## VELVET SMOOTH

Look: Velvet / Feel: Smooth



100  
Graphic

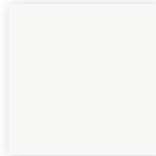

101  
New White



144  
Fennel



145  
Rosehip



146  
Hazelnut



147  
Shadow



148  
Flint



162  
Hokkaido



164  
Iris



166  
Acacia

---

## SEMI GLOSS SMOOTH

Look: Semi Gloss / Feel: Smooth

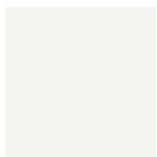

01  
White



02  
Fjord



04  
Anthracite



05  
Black

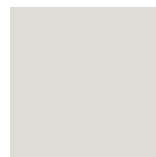

09  
Nordic



150  
Vanilla



151  
Rhubarb



152  
Parsley



154  
Azure



155  
Masala



160  
Balsamic



165  
Beetroot

---

## HIGH GLOSS SMOOTH

Look: High Gloss / Feel: Smooth

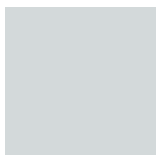

156  
Oyster



157  
Cumin

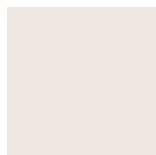

158  
Oat



159  
Camomile



# Montana Furniture

## Technical specification



# Technical specification

Montana Furniture A/S produces and markets storage solutions, tables, and chairs for homes and modern office environments. The Montana System is designed by Peter J. Lassen, and Montana's color palette is created by Margrethe Odgaard. The Paradigm modular sofa is designed by Erik Rasmussen. Montana's table and chair series are designed by Arne Jacobsen, Verner Panton, Peter J. Lassen, Joakim Lassen, Schmidt Hammer Lassen Design, Jacob Wagner, and Kasper Mose.

## MONTANA SYSTEM – RECOMMENDATIONS AND CONFIGURATIONS

Montana is a high-quality industrial product. Design and quality control ensure that the Montana modules, when used correctly, last well into the future. Montana is basically designed and constructed on the assumption that a fixed vertical divider is included, which connects the top and bottom. If you choose not to follow this rule, you must respect that restrictions may arise in other areas.

### Modules on plinths

Use a spirit level and the adjusting screws, all of which must have floor contact, underneath the plinth to make the plinth horizontal. The shelving modules are then mounted easily and effortlessly. Shelving modules on plinths of heights 69.6 cm (\*12), 46.8 cm (\*8) and 35.4 cm (\*6) in depths of 20, 30 and 38 cm can withstand a load of up to 60 kg. Shelving modules on plinths of heights 24 cm (\*4) and 18.3 cm (\*3) and in depth 46.8 cm have reduced load capacity and may therefore only be loaded with up to 40 kg. This applies provided that the module width of 69.6 cm is provided with a vertical divider. When stacking modules on a plinth, it is recommended that suspensions be mounted from a height of 144.5 cm (\*25), in order to comply with load, stability and safety. When modules are stacked, they stand on four small anti-slip pads, which are placed in the corners of the lower module, ensuring that the stacked module is placed securely. Modules at the bottom of an installation must have vertical dividers due to the load at the top.

### Modules on legs

Shelving modules on legs, depending on the module's layout, can be loaded with 50 kg. The maximum height for modules on legs is two modules of 69.6 cm (\*12), but the maximum load for a set of legs is 75 kg.

Modules with a width of 69.6 cm (\*12) with legs must always be provided with a support rail (SS60) under the bottom, to avoid bending. The third module in height must be provided with suspension to ensure load, stability and safety. Mounting legs under modules with a width of 69.6 cm (\*12) without support rail (SS60), is at the customer's own risk and without warranty from Montana. This applies provided that a module with a width of 69.6 cm (\*12) is provided with a continuous vertical divider.

Legs can be adjusted with the adjusting screw at the bottom of the leg.

### Modules on castors

Modules with a width of 69.6 cm (\*12) on castors must always be fitted with a support rail (SS60) under the bottom to avoid bending.

It is only recommended to stack modules in depth 30 and 38 cm up to a height of 104.6 cm (\*18). Modules with a depth of 46.8 cm can be stacked to a height of 138.8 cm (\*24) to ensure load, stability and safety. Mounting castors on modules in 69.6 cm (\*12) in width without support rail (SS60), is at the customer's own risk and without warranty from Montana. This applies provided that the module width 69.6 cm (\*12) is provided with a continuous vertical divider.

### Modules on suspension

Montana's suspension rails consist of two suspension brackets in black recycled plastic. Wall suspension rail in plywood fitted with an adjustment bracket that allows the suspension to be adjusted horizontally. Spacer knobs are mounted on the rear panel, for adjustment against the wall. Modules with suspension hang 8 mm from the wall, allowing concealed cabling.

Suspended shelving modules of heights 69.6 cm (\*12), 46.8 cm (\*8) and 35.4 cm (\*6) in depths of 20, 30 and 38 cm can withstand a load in and on the module of up to 40 kg, provided the nature of the wall as well as the fastening allow this. Suspended shelving modules at the same heights in a depth of 46.8 cm may be loaded with a maximum of 20 kg. Suspended shelving modules at heights of 24 cm (\*4), 18.3 cm (\*3) and 12.6 cm (\*2) have reduced load capacity and may therefore only be loaded with up to 10 kg. Concrete and brick walls are preferable, whereas plaster walls must be a minimum of 2 layers.

### Modules without vertical divider in width 69.6 cm (\*12)

Please note that module tops, shelves and bottoms with a width of 69.6 cm (\*12) can only be loaded with 3 kg. If a larger load is required, support rail SS10 must be mounted underneath the module. Then the module tops, shelves and bottom may be loaded with a maximum of 10 kg in total.

You get the greatest freedom to change installations if you choose modules with a vertical divider. Modules at the bottom of an installation must have vertical dividers due to the load at the top.

Basic module 1111, width 69.6 cm (\*12) x height 69.6 cm (\*12) is generally not sold unfurnished, due to stability and durability. When purchasing this module without interior, it is without warranty from Montana.

### Modules with drawers in width 69.6 cm (\*12)

Please note that the module top in width 69.6 cm (\*12) must be loaded with a maximum of 10 kg, as it is equipped with support rail SS10. If you want to place other modules on such a module, they must always be suspended.

### Modules on base units

It is always recommended to fasten installations on base units with screws directly in the base. All modules are connected together for greater stability. Max. shelf height on base units is 139.2 cm (\*24) at depths of up to 38 cm.

Max. shelf height on base units is 105 cm (\*18) at depths from 38 cm up to and including 60 cm. The number of castors is adapted to the length of the base units and is indicative. The exact number of castors is assessed based on the specific installation.

For lengths 24-69.6 cm: Max. load 75 kg.



# Technical specification

At length 69.7-140 cm: Max. load 125 kg.  
For lengths 140.1-210 cm: Max. load 140 kg.  
For lengths 210.1-240 cm: Max. load 150 kg.

The precise number of castors is assessed based on the specific installation. At a minimum, one set of wheels must be calculated per module adjacent to another. It is not recommended to place the base units on CR70 castors.

## Protective sheet

Shelves can be protected against wear from binders and similar when using a protective sheet. It is always recommended to order protective sheets for modules to be used in offices or home offices. Protective sheets are transparent and have an edge that can be broken off, so that they also fit in the space behind doors. C016 modules are fitted with protective sheets as standard.

## Montana TV & Sound width 46,8 cm (\*8), 69,6 cm (\*12), 138 cm (\*24) and 183,6 cm (\*32) on legs and suspension

Modules in widths of 46.8 cm (\*8), 69.6 cm (\*12), 138 cm (\*24) and 183.6 cm (\*32). The modules are made of 12 mm lacquered MDF. Modules on legs and castors are fitted with a support frame, width 69.6 cm (\*12) SS60, 138 cm (\*24) SS24. Modules width 183.6 cm (\*32) have 6 legs and a support frame SS24. Modules \*32 cannot be fitted with castors.

Modules on suspension are fitted with a two-part suspension that allows wiring to be routed behind the module. The modules may be loaded with 40 kg evenly distributed. The module top may be loaded with a maximum of 20 kg, however, tops/shelves with a width of 69.6 cm (\*12) without a vertical partition may be loaded with a maximum of 10 kg.

## Wardrobe

The Montana Wardrobe is constructed from 16-mm lacquered MDF. For stability, it is recommended that modules mounted on a plinth are connected with screws to prevent twisting. Modules equipped with drawers present an increased risk of tipping; therefore, it is advised that these modules be securely attached to the wall. Modules positioned on a plinth have a maximum load capacity of 40 kg.

The Wardrobe OP9W suspension rail from Montana is reinforced and not suitable for retrofitting. Upon installation, a 12-mm reinforcement strip is doweled into the module's corpus. From the back, the suspension resembles other Montana suspensions, utilizing two black recycled plastic brackets. The Suspension on module is secured through the reinforcement strip, back panel, and plastic brackets. The wall-mounted suspension rail, made of plywood, is supplied with an adjustment bracket allowing for horizontal alignment. Spacer knobs on the back panel facilitate adjustment against the wall. Suspended modules hang 8 mm away from the wall.

Suspended wardrobe modules with heights of 36.2 cm (\*6) and 70.4 cm (\*12) support loads up to 20 kg, while those at 116 cm (\*20), 150.2 cm (\*26), and 186.4 cm (\*32+) can accommodate up to 40 kg. Drawers have a maximum load of 15 kg each; however, the total weight must never exceed the module's specified limit. It is also recommended to interconnect modules for added safety.

For optimal security, installation should preferably be on concrete or brick walls; plaster walls must consist of at least two layers.

## Modules of 16-mm width 81.8 cm (\*14) and 121.7 cm (\*21) on plinths, castors, legs or suspension

A support rail is mounted under modules in width 81.8 cm (\*14) when castors and legs are selected. Modules in width 81.8 cm (\*14) without vertical divider must not be placed on castors, legs or suspension. For modules 121.7 cm (\*21), 5 castors are mounted. Modules in width 81.8 cm (\*14) and 121.7 cm (\*21) with legs must always be fitted with a lange.

Modules on a plinth can be loaded with 60 kg, evenly placed.

Modules on castors can be loaded with 80 kg, evenly placed.

Modules on legs can be loaded with 50 kg, evenly placed.

Modules on suspension can be loaded with a maximum of 40 kg, evenly placed. It is important that installations mounted with legs and castors are level. If not, the module will twist. Legs can be adjusted with the adjusting screw at the bottom of the leg.

## Panton Wire

The wire rack is made of chrome-plated and powder-coated 5-mm wire. It is available in 2 variants, in 2 depths. The shelves are delivered with suspension rails, feet and assembly clips. It is recommended to use the enclosed securing strap, for wall mounting, for installations over 100 cm in height. All Panton Wire variants with suspension can carry a load of max. 10 kg. Standing, the square shelf can be loaded with 40 kg. The rectangular with 10 kg.

## Montana and wet environment

We advise against using Montana modules in wet rooms or wet environments. Instead, we recommend Montana Bathroom products. Montana Bathroom products are made of water-resistant MDF. The Montana products mirrors, Living Things and coat racks can be used in wet rooms, but must not be placed in places where they can be exposed to splashes from the shower or bath.

## Measurements

Montana is a system design based on the dimension of 5.7 cm. The dimensions connect Montana's dimensions with the DIN formats, which makes Montana ideal for storage without wasted space for paper, folders, books etc. at home and in the workplace.

\* The star dimensions in the model overviews listed in parentheses indicate dimensions in cm. Outer and internal measurements are found for the individual modules and components. Dimensions for tables and chairs are also available below each product series.

## Surfaces and colours

After sanding, all edges and surfaces of the Montana storage system are primed four times with UV-curing lacquer and finely sanded. Montana's surface lacquer is a water-based highly resistant UV quality lacquer. The lacquer is formaldehyde-free and the evaporation does not contain any harmful substances. Emissions of organic solvents have been reduced to a minimum, which is far below the requirements of the EU VOC Directive. By using water-based lacquer, Montana protects the environment from solvents and contributes to a better indoor climate at home and in the workplace. Distance to heat sources: Modules may be exposed to a maximum of 60C. There may be slight smudging when wiping lacquered surfaces in strong colours/shades with a damp cloth.



# Technical specification

## QUALITY AND WARRANTIES

Montana furniture is manufactured at our factory in Haarby, Denmark, with the exception of all chairs, sofas, and Panton products, which are all produced in Europe. Construction and quality control ensure that Montana products, when used correctly, last well into the future. With proper assembly and use of Montana products, as well as under normal conditions including recommendations regarding load, Montana Furniture A/S provides a 10-year durability warranty for construction, moving parts, and functionality. For tables, chairs, sofas, Rector® sinks, electronic and hydraulic components, there is a 5-year warranty. Code locks and electronic locks have a 1-year warranty. Regarding the durability of the lacquer, normal wear and tear applies. Discontinued colours and sizes in the Montana storage system can be supplemented subject to availability. However, we reserve the right for slight variations in lacquer shades as well as design improvements resulting from new technology and raw material recipes. With the supplementary warranty, Montana products represent a sound, long-term investment.

## ENVIRONMENT AND WORKPLACE CONDITIONS

Since its establishment in 1982, Montana has incorporated both environmental and workplace safety perspectives into its business foundation. Montana's management system ensures that environmental and workplace considerations are taken into account in all decision-making processes on an equal footing with design, quality, technology, and finance. Montana prepares an annual environmental and workplace report detailing the status and efforts in these areas. Montana is environmentally certified according to ISO 14001.

## EU Ecolabel

The Montana System, Montana System C016, Montana Free Shelf, HiLow Table series, JW Table, Multi Cafe and Speaker, Panton Table, Skyline shelves/tables, Panton Wire, Pantonova, Panton One, Montana Mini and Paradigm sofa are all certified with the EU Ecolabel. The EU Ecolabel represents stringent environmental requirements and strict chemical regulations to reduce the overall environmental impact from production and consumption. The EU Ecolabel regularly tightens requirements to foster sustainable development, considering the entire product lifecycle and associated environmental issues – for the benefit of people, the environment, and the Earth's resources.

## PEFC-Certified Wood

In 2022, Montana became PEFC certified, marking an important step towards increased responsibility in the value chain. Today, the majority of our MDF-based components are made from PEFC-certified wood. PEFC is an international certification that verifies the wood comes from sustainably managed forests and suppliers who take into account environmental, biodiversity, and social considerations. This provides assurance that responsibility has been taken throughout the entire process – from forest to finished furniture.



**Cleaning and maintenance**  
Find our maintenance guide here: >



**See order information and updated delivery times here: >**



**Montana Furniture - Conditions of sale and delivery >**





Montana Furniture A/S  
Akkerupvej 16, DK 5683 Haarby, Denmark  
T: +45 6473 3211 E: montana@montana.dk  
montana.dk