

Chest of drawers, tall  
Byrå, hög  
Kommode, hoch  
ハイチェスト

≡relief



Scan QR code to watch or download assembly instructions.  
Made in Sweden. [stringfurniture.com](http://stringfurniture.com)

Fittings for frame

Fittings for tip protection

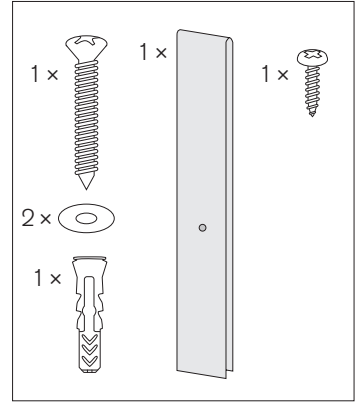
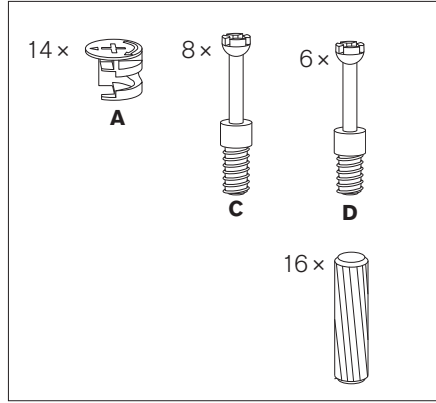

Fittings for drawers

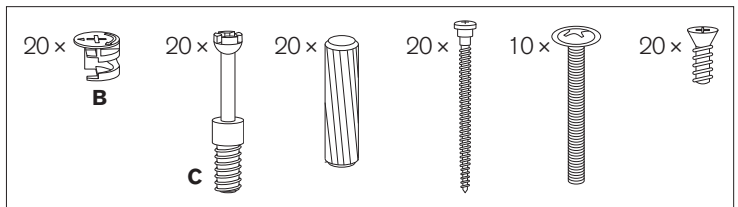

Fittings for plinth

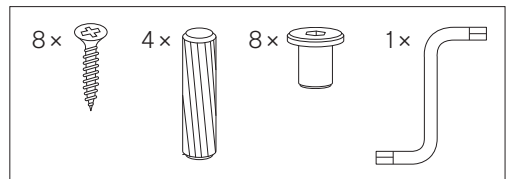

Fittings for leg

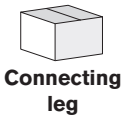
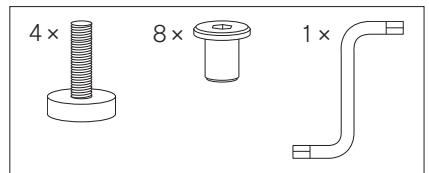

Fittings for connecting leg

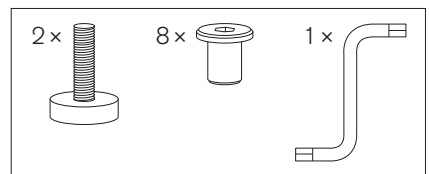

Do not use an electric screwdriver to assemble.  
電動ドライバーは使用しないでください。

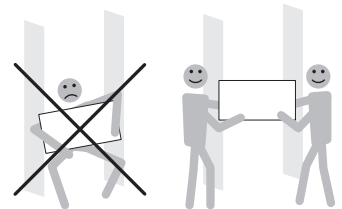

## Svenska

Detta är en produkt tillverkad av det svenska designföretaget String Furniture AB.

För byrå rekommenderas max 30 kg jämnt fördelad last per låda.

**WARNING** Om byrån tippar kan kläm-, sak- eller personsador uppstå. Undvik att byrån tippar genom att säkerställa att byrån sitter ordentligt förankrad i väggen med hjälp av skruvar och/eller pluggar som lämpar sig för materialet i väggen. Följ dessutom monteringsanvisningen noga vid montering av byrån.

För råd om lämpliga skruvsystem kontakta din lokala fackhandlare.

## English

This is a product manufactured by the Swedish design company String Furniture AB.

For chests of drawers, we recommend max. 30 kg / 66 lbs. evenly spread load per drawer.

**CAUTION** If the chest of drawers falls over, crushing, damage to property or personal injury can occur. Avoid the chest of drawers from falling over by keeping the chest of drawers permanently fixed to the wall using screws and/or plugs designed for your wall material and follow the assembly instructions carefully when mounting the chest of drawers.

Get advice on suitable screw system from your local specialized dealer.

## Deutsch

Dieses Produkt ist von der schwedischen Designfirma String Furniture AB hergestellt.

Für die Schubladen wird eine gleichmäßig verteilte Last von maximal 30 kg pro Schublade empfohlen.

**ACHTUNG** Wenn die Kommode umkippt, kann es zu Quetschungen, Sachschäden oder Verletzungen kommen. Um ein Umkippen der Kommode zu verhindern, stellen Sie sicher, dass die Kommode mit für die Wand geeigneten Schrauben und/oder Dübeln ordnungsgemäß verankert ist. Halten Sie sich bei der Montage der Kommode außerdem genau an die Montageanleitung.

Wenden Sie sich an Ihren Fachhändler, um sich über geeignete Schrauben und Dübel beraten zu lassen.

## 日本語

これはスウェーデンのデザイン会社String Furniture ABが製造した製品です。

チェストの耐荷重は30kgを推奨しています。荷重を均等にしてお使いください。

**注意** チェストが転倒すると収納物の落下や破損、大ケガや死亡事故に繋がる可能性があります。壁の材質に合ったネジやプラグを使用して、壁に固定するなど、転倒防止策を施すことをおすすめします。チェストを壁固定する際は、説明書の手順に従ってください。詳しくは販売店、工務店やホームセンターにご確認ください。

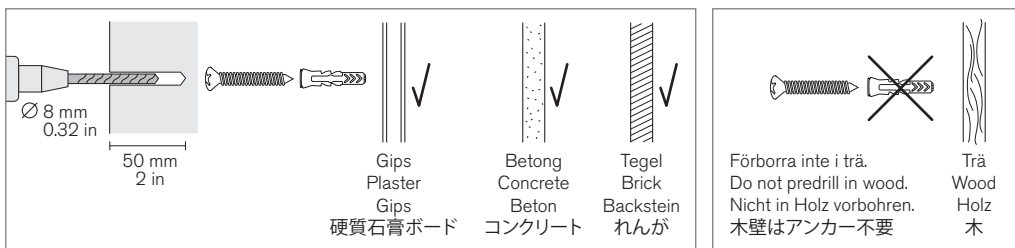

## Svenska

Beslagen som medföljer är avsedda för montering i väggar av god kvalitet. Skruvarna är avsedda för montering, utan plugg, i träbaserade väggskivor. Om väggarna är gjorda av gips, betong eller tegel så används den inkluderade pluggen med samma skruv. Vid minsta osäkerhet, eller om väggarna är gjorda av annat material, kontakta din lokala specialiserade återförsäljare för val av lämplig skruv och plugg för uppsättningen.

## English

The brackets supplied are designed for mounting on high-quality walls. The screws are designed for installation without plugs in wood-based wall panels. If the walls are made of plaster, concrete or brick, a plug must be used with the screw. If in the slightest doubt or if the walls are made of a different material, contact your local specialist dealer for a suitable screw and plug for the set.

## Deutsch

Der mitgelieferte Beschlag ist für die Montage an hochwertigen Wänden vorgesehen. Die Schrauben sind für die Montage in Wänden aus Holz ohne Dübel vorgesehen. Wenn die Wände aus Gips, Beton oder Ziegeln bestehen, muss der mitgelieferte Dübel mit der gleichen Schraube verwendet werden. Bei der geringsten Unsicherheit oder wenn die Wände aus anderen Materialien gefertigt wurden, wenden Sie sich an Ihren Fachhändler vor Ort, um die passenden Schrauben und Dübel für das Set auszuwählen.

## 日本語

付属のアンカーは硬質石膏ボード、コンクリート、レンガに適応しています。一般的な日本の石膏ボードに取り付ける際は、プラスチックドライバーだけで簡単に取り付けできる下穴不要の石膏ボード専用アンカーを使用してください。詳しくは販売店へお問い合わせください。

Option – plinth:



Steps: ① – ②    ⑥ – ②⑥

---

Option – leg:



Steps: ③ – ④    ⑥ – ②⑥

---

Option – connecting leg:



Steps: ⑤    ⑥<sup>2x</sup> – ②⑥

1

Option – plinth:

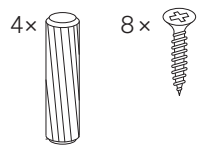
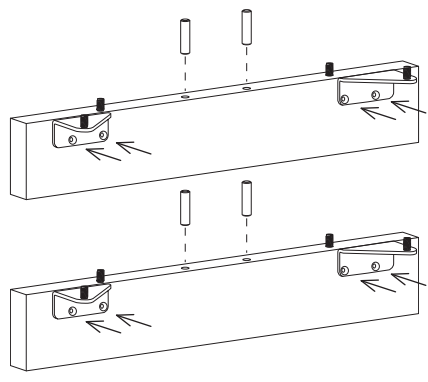

2

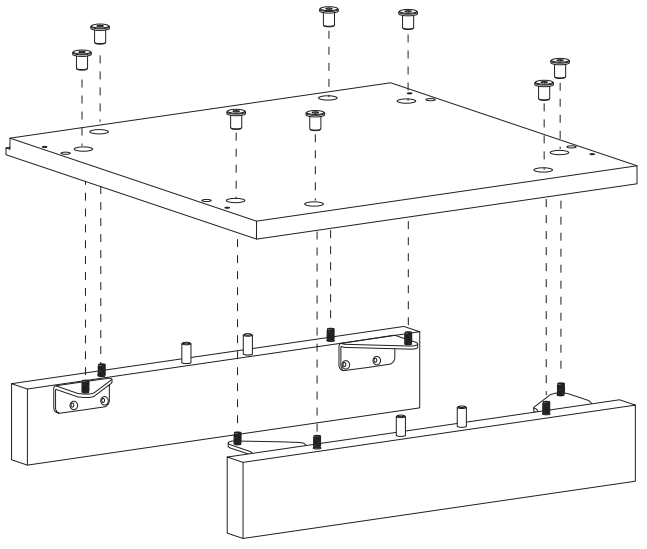
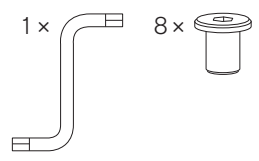

3

Option – leg:

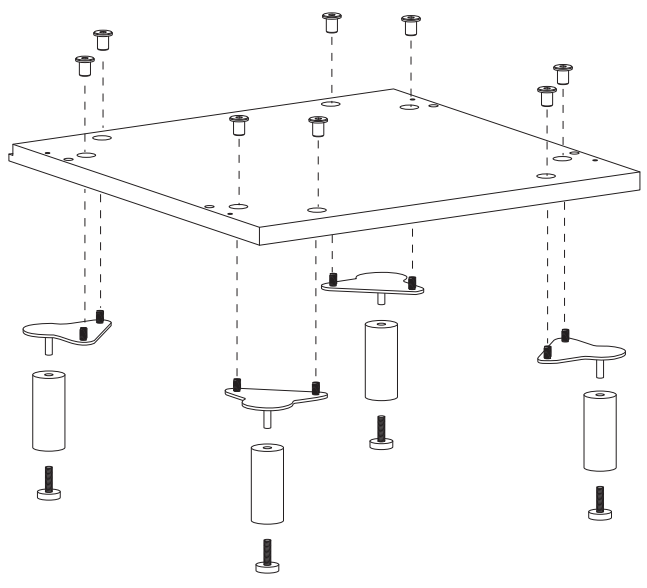
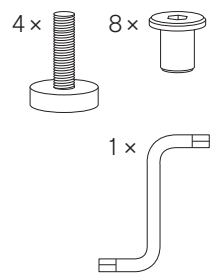

4

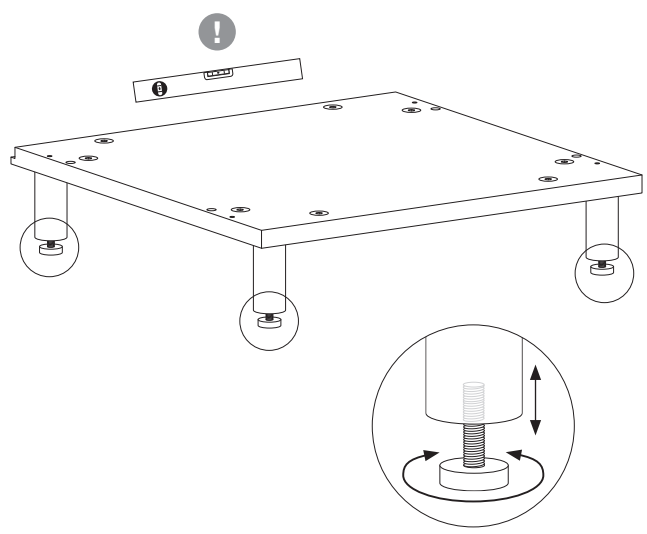

5

Option – connecting leg:

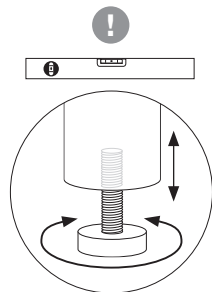
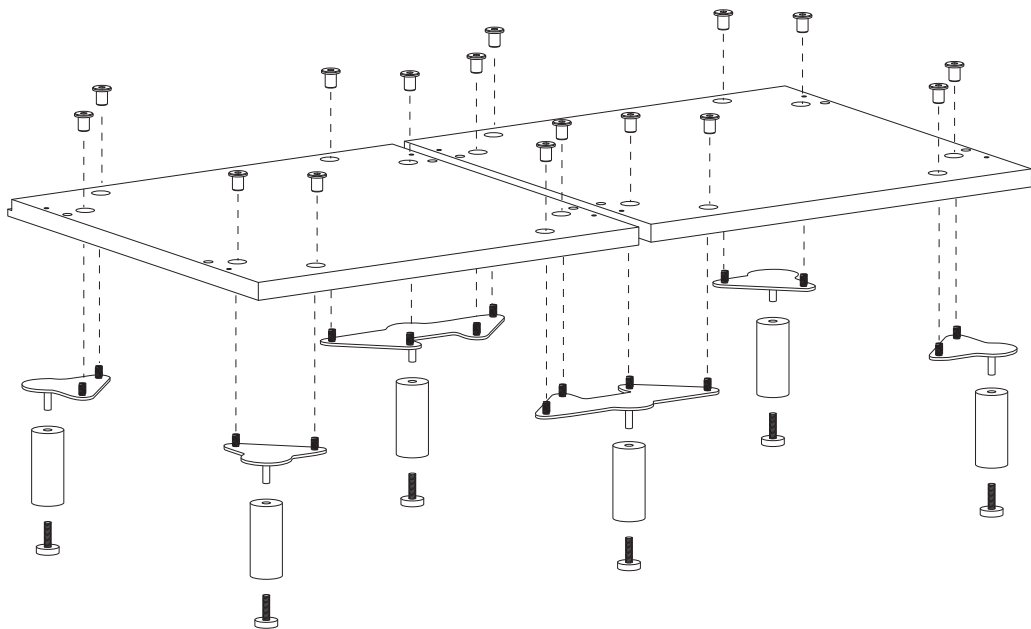
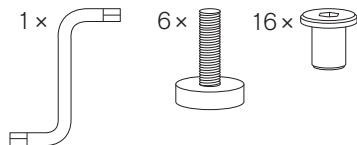
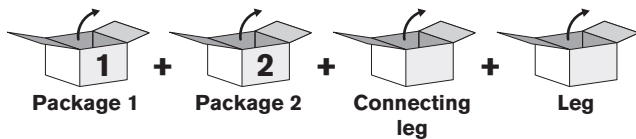

6

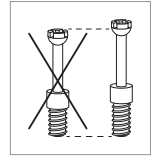
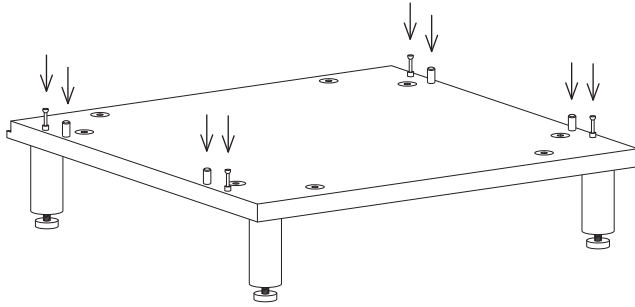
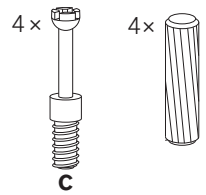

7

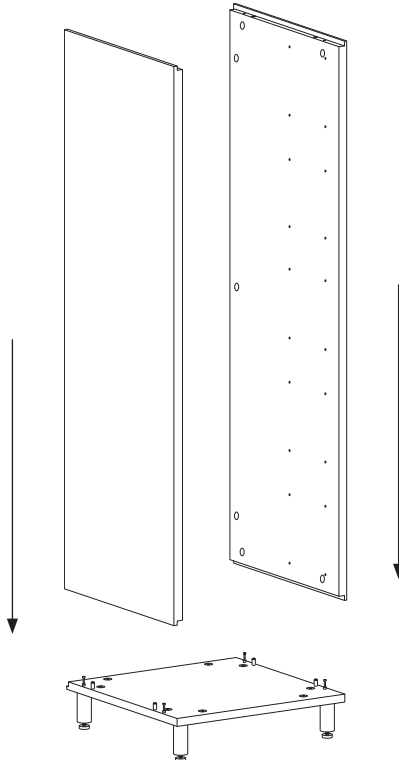



8

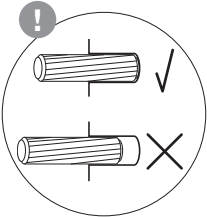
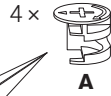
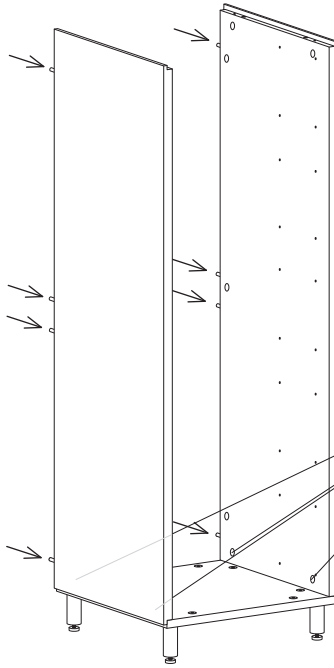

9

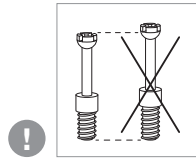
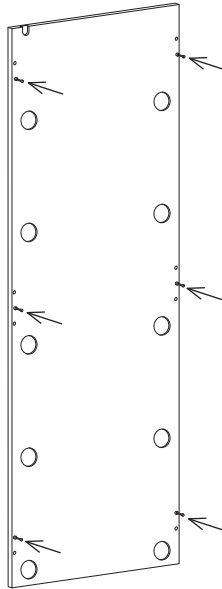

10

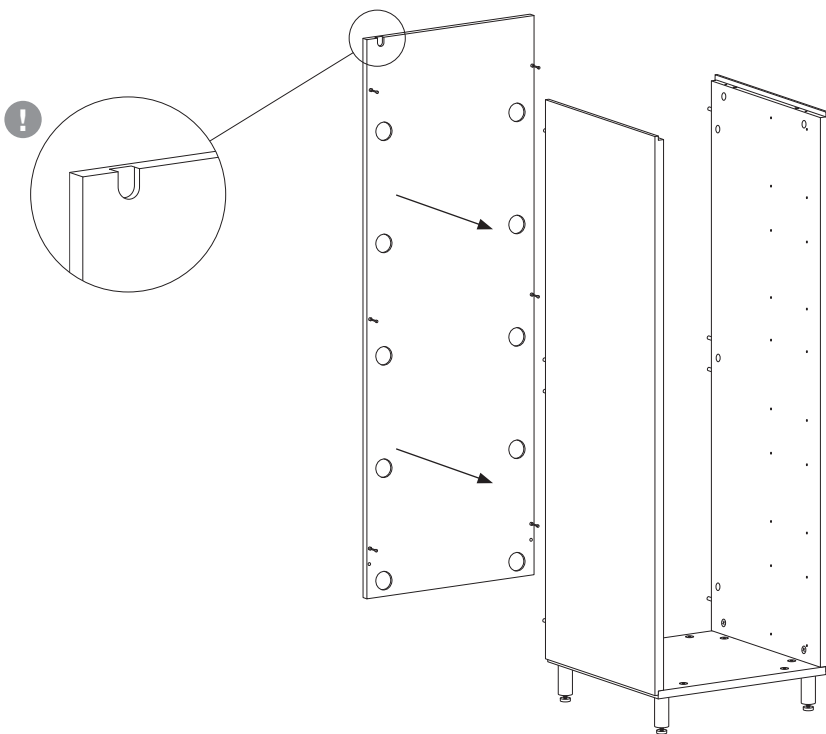

11

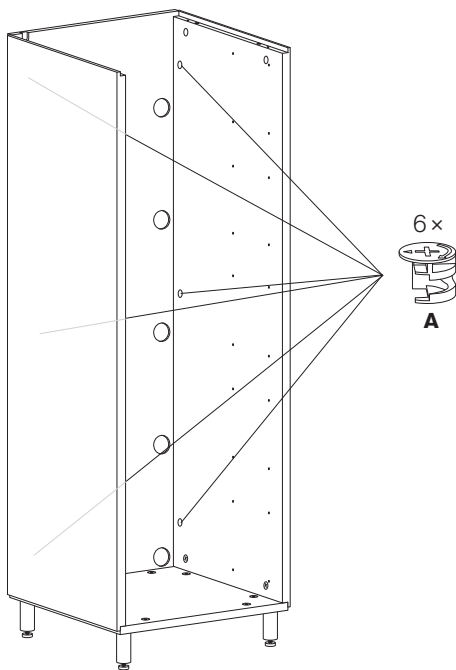

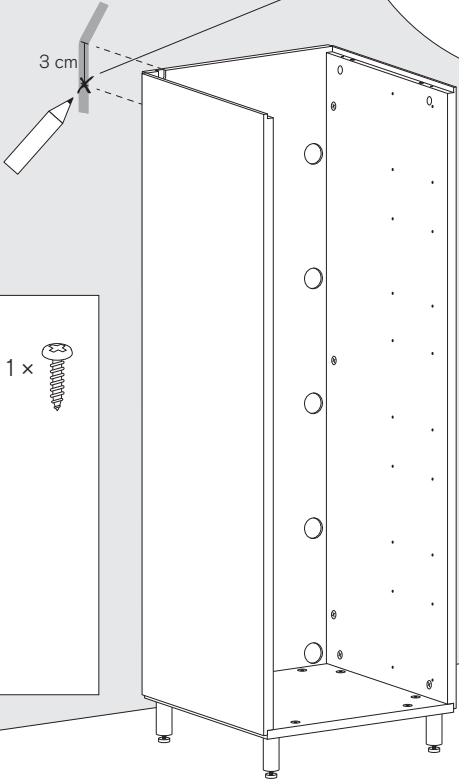
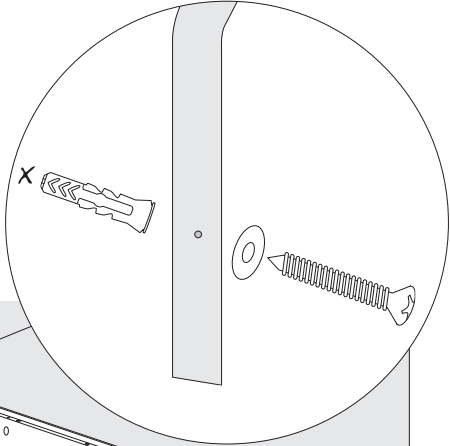
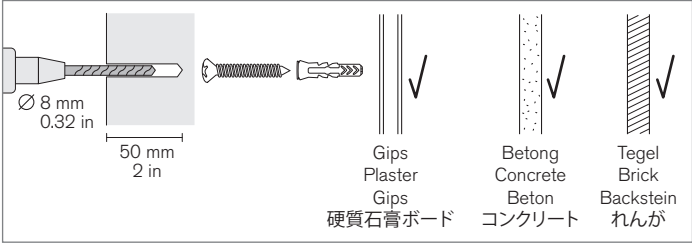

Option

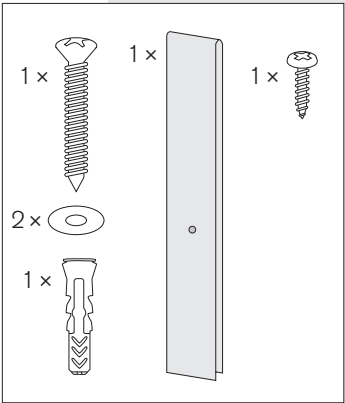

**13** Option

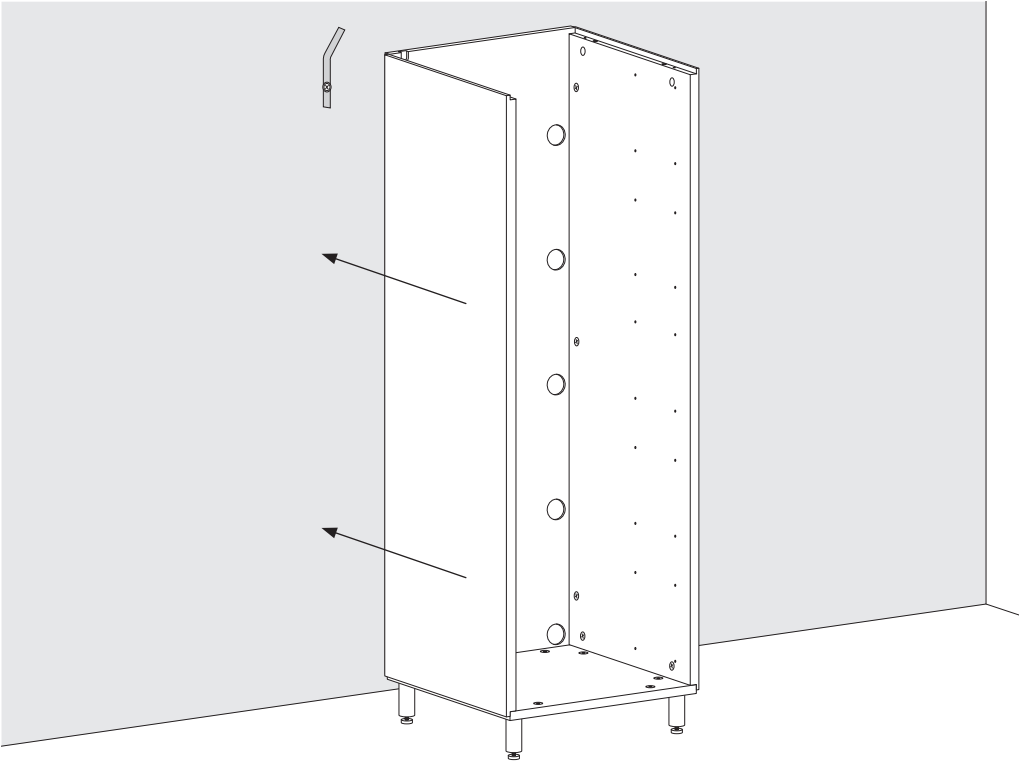

**14**

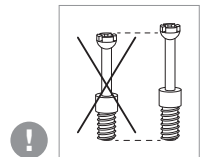
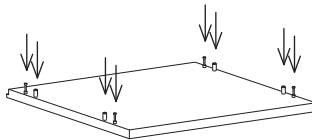
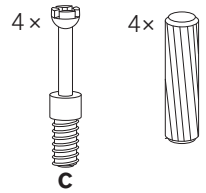

15

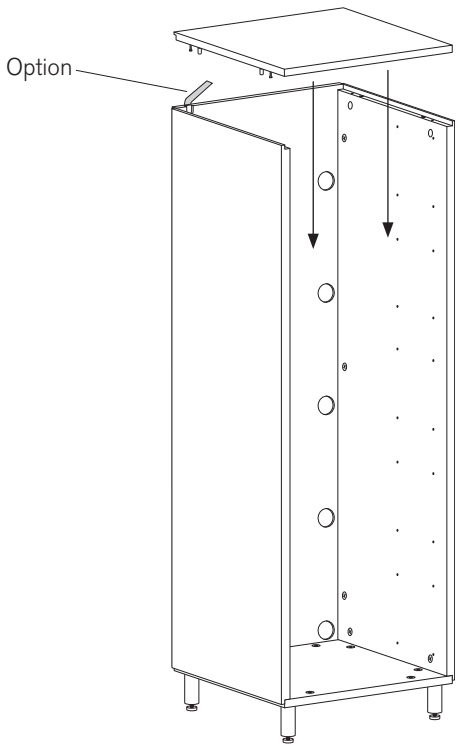

16

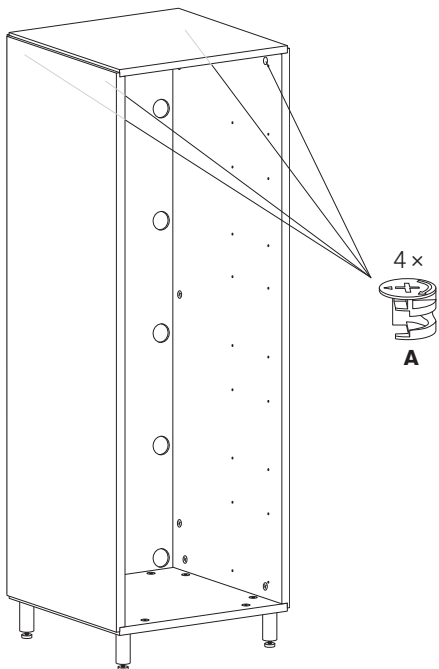

17

Option

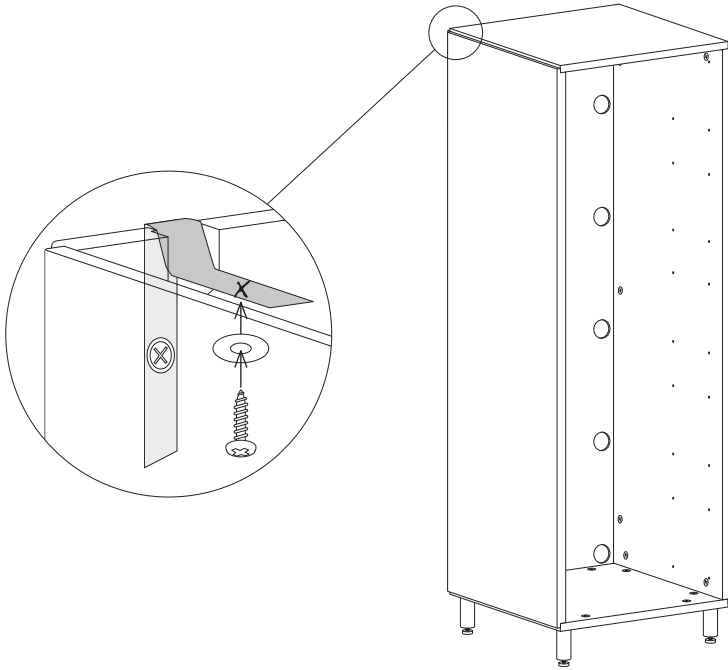

18



Package 3

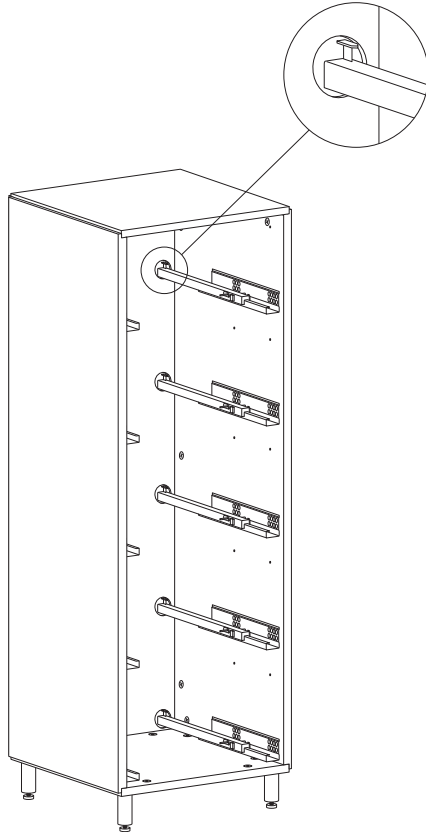

20 x 

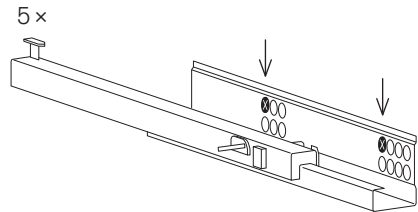
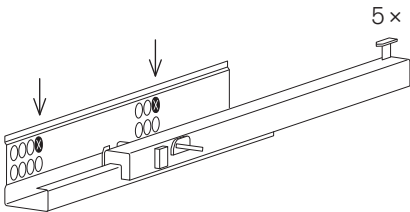

19 x 5

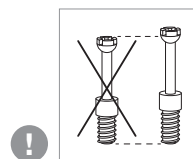
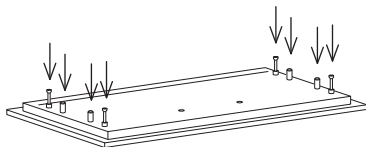
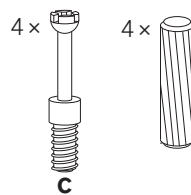

20 x 5

4 x 

**B**

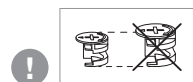
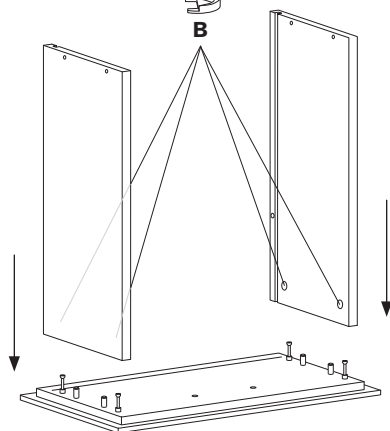



21 x 5

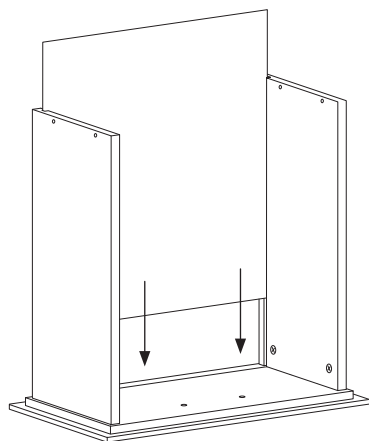

22 x 5

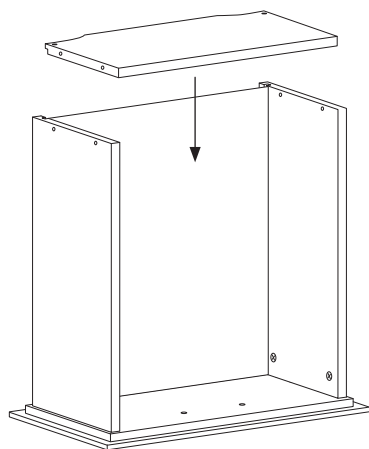

23 x 5

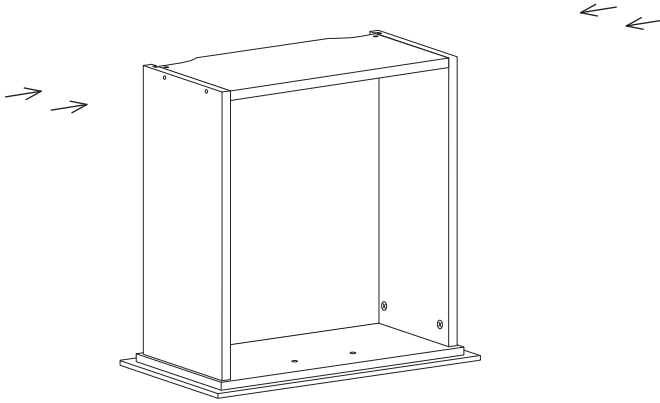

24 x 5

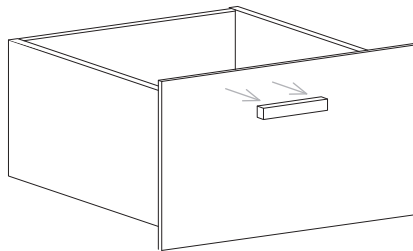
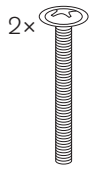

25 x 5

