

Compas Direction

Jean Prouvé, 1953

vitra.



Jean Prouvé developed several versions of the Compas table around 1950, basing the design on the structural principles for which he is known. Common to all of them are the slender, elegantly splayed legs, which call to mind the hinged arms of a compass – ‘le compas’ in French.

The solid wood table top gives Compas Direction an individual touch. With its compact dimensions, the desk is ideal for the contemporary, largely paperless home office.

Materials

- **Table top:** solid wood in oak, natural, oiled finish; oak, dark hard-wax oil finish, or American walnut, natural, oiled finish.
- **Base:** bent sheet steel, powder-coated finish (smooth).
- **Origin of wood:** oak (*Quercus robur*) from Western Europe and/or Poland; American walnut (*Juglans nigra*) from the USA.

DIMENSIONS

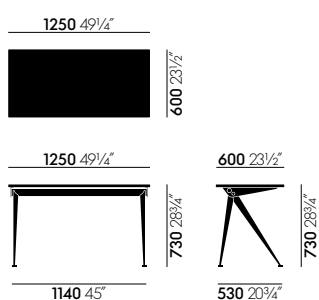

Compas Direction 1250 x 600

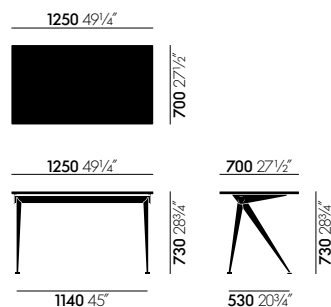

Compas Direction 1250 x 700

COLOURS AND MATERIALS



70
oak, natural, oiled
finish



75
American walnut,
natural, oiled finish



04
oak, dark, hard-wax
oil finish

Table top



88
Prouvé Blanc
Colombe (Ecru)
powder-coated
(smooth)



06
Japanese red
powder-coated
(smooth)



12
deep black
powder-coated
(smooth)

Base frame
Colour group 1



13
Prouvé Gris
Vermeer powder-
coated (smooth)



18
Prouvé Blé Vert
powder-coated
(smooth)



41
Prouvé Bleu
Marcoule powder-
coated (smooth)



14
Prouvé Bleu
Dynastie powder-
coated (smooth)

Base frame
Colour group 2

